



8946183



New EOS models - MICRON - SV MRO  
New MOSAIC expansions - SAFECODER

SAFETY AUTOMATION MEASUREMENT AND CONTROL - Catalog n. 20

**REER S.p.A.**

10153 TORINO - Italy  
Via Carcano, 32  
Tel. +39 011 2482215  
Fax +39 011 859867

[www.reer.it](http://www.reer.it)  
[info@reer.it](mailto:info@reer.it)



**SAFETY AUTOMATION MEASUREMENT AND CONTROL**  
Catalog n. 20



# INTRODUCTION

The present edition of Reer Safety and Automation Catalog presents at least one novelty of great interest, as you can see from the summary of new products placed at the bottom of this introduction.

The line of configurable safety controllers Mosaic has grown thanks to new expansion modules that allow you to further extend the applications of this versatile product.

Among the new features we put in evidence the new family of MV expansions modules, which allows safe monitoring (SIL 3) of the motor-axis speed. In this context, the introduction of the new incremental safety encoder SIL 3 Safecoder, is particularly important.

Leafing through the pages of the dedicated section, in addition, you can investigate the characteristics that make Mosaic safety controller unique and innovative: the powerful, versatile and easy to use graphical configuration software (MSD) up to the extreme modularity and compactness of the hardware.

The already popular EOS line of safety light curtains is enriched by further models, in particular by the ATEX version, while the IP69K-rated WT series, optimised for applications in the food & beverage industry has been awarded with the ECOLAB label.

Finally, in the field of measurement, automation and control light curtains comes "Micron" with reduced dimensions, but with a large amplitude of the range and versatility of application.

We do hope that all these news will be a stimulus for you, as well as a valid support in doing your work.

Turin, October 2013

## WHAT'S NEW IN THIS EDITION

New EOS4 model to to increase the controlled heights up to 1800 mm

See table from page. 57

New EOS2 model to to increase the controlled heights up to 1800 mm

See table from page 123

Additional L and T Muting arms for ADMIRAL e VISION light curtains

See page 83

New MOSAIC expansion modules:

- MV Modules serier for safety speed monitoring
- MRO4 and MRO4 S8 Modules - Safety relay expansion unit with configurable output.



See pages 168 - 169

**MOSAIC**

SAFECODER - Sin/Cos incremental safety encoders

**SAFECODER**



See page 180

SV MRO - Safety speed monitoring interface



See page 182

ECOLAB certification for watertight IP 69K WTF and WTHF light curtains EOS4 and EOS2



See page 194

Measurement and automation and control light curtain

**Micron**



See page 200

Note: all ordering codes have been reordered and are reported in the tables of the characteristics of the product.

# TABLE OF CONTENTS

## SAFETY GUIDE

### SAFETY IN WORKING ENVIRONMENT

<b>International standards</b>	Page 6
European directives	Page 6
Harmonised standards	Page 10
Northern American standards and test bodies	Page 11
<b>Risk assessment</b>	Page 13
Safety related control system for machinery	Page 14
The old EN 954-1 and the new Standards	Page 14
The new Standards (13849-1)	Page 16
Conclusions	Page 26
<b>Glossary</b>	Page 28

### PHOTOELECTRIC SAFETY LIGHT CURTAINS

<b>Characteristic elements</b>	Page 30
<b>Selection criteria</b>	Page 32
<b>Determination of the safety distance</b>	Page 34
<b>Muting Function</b>	Page 39
<b>Blanking Function</b>	Page 43

### SAFETY LASER SCANNER

<b>Characteristic elements</b>	Page 44
<b>Principle of operation</b>	Page 45
<b>Controlled areas</b>	Page 46
<b>Applicatios</b>	Page 47

### INTEGRATION OF THE ESPE

<b>Rules for correct interconnection of protection devices to machine control system</b>	Page 48
--	---------

## SAFETY SENSORS

<b>Selection guide</b>		Page 49
<b>EOS4</b>	Type 4 light curtains	Page 55
<b>ADMIRAL</b>	Type 4 light curtains	Page 71
<b>JANUS</b>	Type 4 light curtains	Page 87
<b>PHARO</b>	Type 3 laser scanner	Page 115
<b>EOS2</b>	Type 2 light curtains	Page 121
<b>VISION</b>	Type 2 light curtains	Page 133
<b>ILION</b>	Type 2 photocells	Page 156
<b>ULISSE</b>	Type 2 photocells	Page 158
<b>MAGNUS</b>	Magnetic Safety Switches	Page 159
<b>SAFECODER</b>	Incremental safety encoders	Page 179

## CONFIGURABLE SAFETY CONTROLLER

<b>MOSAIC</b>	Modular Safety Integrated Controller	Page 165
---------------	--------------------------------------	----------

## SAFETY INTERFACES

<b>SV MRO</b>	PL e - SIL 3 Safety speed monitoring interface	Page 182
<b>AD SR1</b>	Type 4 interface for light curtains	Page 184
<b>AD SRM</b>	Type 4 interface with muting for light curtains	Page 185
<b>AD SRT</b>	PL e safety interface for two-hand control	Page 186
<b>AD SRE4 - AD SRE4C</b>	PL e safety interfaces for emergency stop buttons and safety switches	Page 187
<b>AD SRE3 - AD SRE3C</b>	PL d safety interfaces for emergency stop buttons and safety switches	Page 188
<b>MG d1</b>	PL d for Magnus magnetic switches control unit	Page 189
<b>AU SX</b>	Type 2 control unit for Ilion and Ulisse photocells	Page 190
<b>AU SXM</b>	Type 2 control unit with muting for Ilion and Ulisse photocells	Page 191
<b>AD SRO - AD SROA</b>	Safety relay modules for devices with integrated feedback input for EDM	Page 192

## WATERTIGHT ENCLOSURES

---

<b>EOS4 and EOS2 WTF and WTHF versions</b>	Page 194
<b>ADMIRAL AX and VISION VX WT and WTH versions</b>	Page 197

## MEASUREMENT, AUTOMATION AND CONTROL LIGHT CURTAINS

---

<b>MICRON</b>	Page 199
<b>METRON</b>	Page 211

## ACCESSORIES

---

<b>FMC - Floor support columns</b>	Page 220
<b>FMC B12 - FMC B18 - Support columns</b>	Page 222
<b>SP - Deflection mirrors</b>	Page 223
<b>LAD - Laser alignment devices</b>	Page 224
<b>SAV - Vibration dampers</b>	Page 225
<b>Protective screen for EOS</b>	Page 225
<b>SFB – SFB 4J - SFBE – SFB E180 brackets</b>	Page 226
<b>Test ROD</b>	Page 226



# SAFETY GUIDE

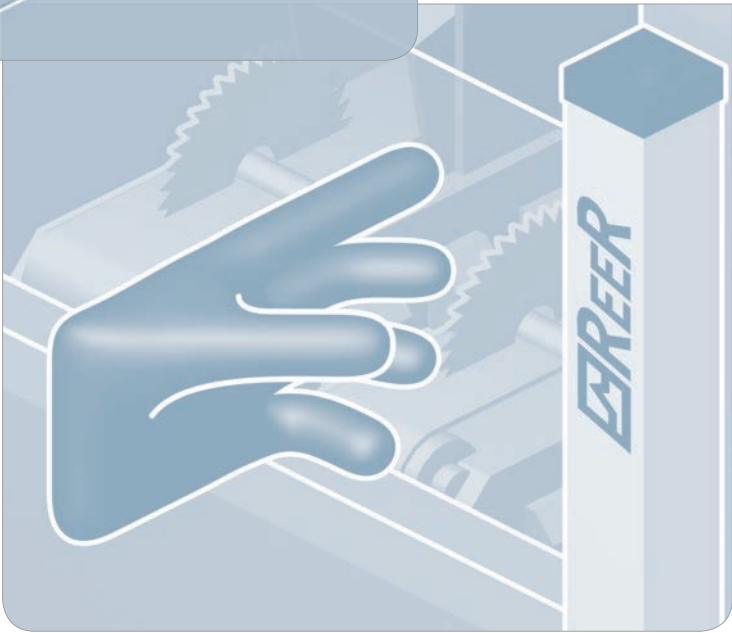
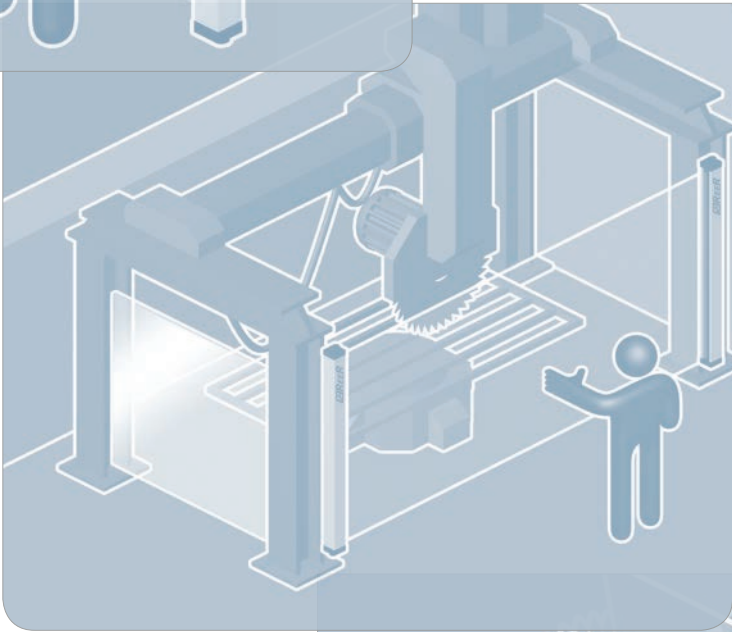
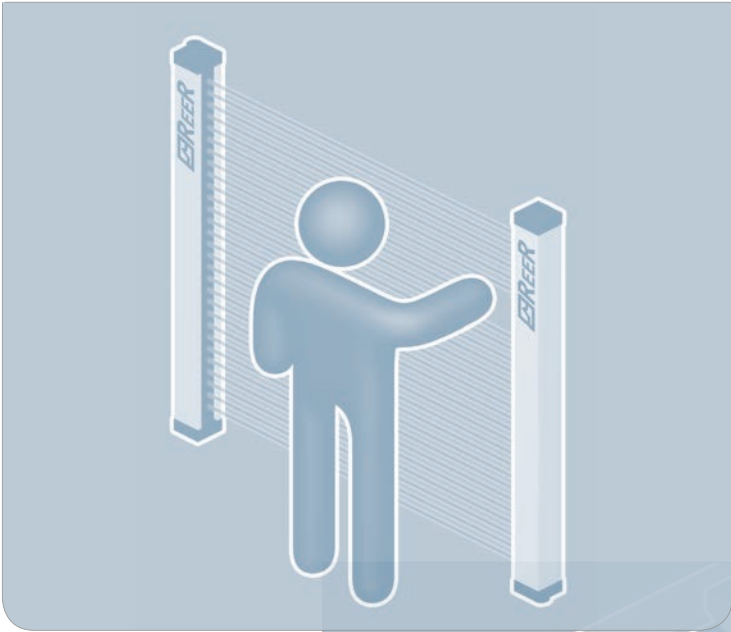

## SAFETY IN THE WORKING ENVIRONMENT

### INTERNATIONAL STANDARD

Many important changes have been introduced in regulations on safety of machinery, starting from 2010. In practice several of these have already had some impact since 2005 and 2006, when the overlap period began for Standards on safety-related machine control systems.

In particular, this concerns the crucial family of Standards under the umbrella of ISO 13849, and IEC 61508 which impacts safety of machinery especially through IEC 62061. Thus, important statistical concepts derived from process safety and related, in varying degrees, to probability of dangerous failure, are covered by machine safety, resulting in new classifications of safety-related control systems for machinery and protection devices. These include PLs (Performance Levels, for ISO) and SILs (Safety Integrity Levels, for IEC). PL and SIL come next to and in many ways replace the now familiar concept of Category featuring in the 'old' EN 954-1.

In 2008 IEC finished the second edition of IEC TS 62046, a specification providing guidelines on the use of safety sensors for machinery protection applications.

This is a novelty the impact of which will be felt worldwide.

Looking nearer home in Europe, the new Machinery Directive 2006/42/EC is effective starting from December 29, 2009. This Directive introduces a number of innovations compared to 98/37/EC.



### EUROPEAN DIRECTIVES

The aim of the EC Directives is to harmonize the national legislation of the Member States so as to have common regulations concerning technical, economic, social aspects, etc. and to facilitate the free circulation of goods, service and people within the European Union.

In particular, where the safety of workers is concerned, the harmonization of legal provisions has resulted in the formulation and approval of Directives and Standards of great importance.

**DIRECTIVES** Define the objectives to be achieved.

**STANDARDS** Define the means and methods by which to achieve the objectives established by the Directives.

A product/service that complies with the harmonized Standards is presumed to conform to the Directives.

#### **Stages for the realization of a Standard:**

- Creation of a Working Group (WG) made by experts of the subject to be treated, which represent the Member States
- Preparation of a draft version of the Standard (prEN) to be examined by the various national Committees involved, for comments, proposals and the subsequent final approval
- Drafting of the definitive formulation of the text of the Standard (EN), official publication, and acceptance by the individual Member States.

#### **The Directives concerning the protection of workers are:**

- 89/391/EC "Health and safety at work - Framework directive"
- 2009/104/EC "Use of work equipment" and amendments / additions

#### **The Directives governing safety components are:**

- 2006/42/EC "Machinery directive"
- 2006/95/EC "Low Voltage Directive"
- 2004/108/EC "Electromagnetic Compatibility Directive"

## SAFETY IN THE WORKING ENVIRONMENT

## SOCIAL DIRECTIVES

“Social Directives” 2009/104/EC and 89/391/EC, are aimed at the improvement of safety in working environment.

### The Directives:

- Determine the preventive measures to be adopted in the working environment.
- Supply information on:
  - risk analysis;
  - program of prevention and achievement of compliance of the machines;
  - procedures concerning the compliance of machines;
  - responsibilities of the employer;
  - education and training of the people in charge of system operation.
- Imposes the adaptation of existing machinery in compliance with the provisions of the Machinery Directive.

## THE MACHINERY DIRECTIVE

**The “Machinery Directive” 2006/42/EC is meant for the manufacturers of machines and safety components, and has the following objectives:**

- The definition of safety and health protection requirements for the improvement of the degree of protection offered to the operators of hazardous machinery.
- The design, construction and marketing in the European Union of safety machines and components complying with the minimum safety requirements laid down by the Directive itself.
- The free circulation in the Member States of machines and safety components complying with the Directive.

### The Machinery Directive:

- It applies to all new machines and safety components that are sold, lent or hired, and to used machinery in the event of sale, rental or loan.
- It sets forth the essential safety requirements relating to the design and construction of machines and safety components and it defines the respective certification procedures.
- It is mandatory for machines and for safety components.
- Only products conforming to the Directive can be marketed or commissioned in the European Union.

## Certification procedures

### The Directive:

- Lays down stringent procedures for safety components and highly hazardous machines which are listed in Annex 4.
- Lays down simplified procedures for low and medium risk machines not included in annex 4.
- Requires that manufacturers prepare a technical dossier for each product stating the safety principles adopted in the design, manufacture, transport, use and maintenance of the machine or the safety component.

## Declaration of conformity

**In order to certify the conformity of a product to the Directive, the manufacturer must:**

- Affix the CE mark to the product.
- Attach the CE declaration of conformity attesting compliance to the Directive.



# SAFETY IN THE WORKING ENVIRONMENT

## THE MACHINERY DIRECTIVE 2006/42/EC

### Main objectives of the revision

#### Clarity

- The list of products covered by the Directive is more explicit.
- New product classes have been added.
- Borderline relative to other Directives have been clarified.
- Definitions have been improved.

#### Legal certainty

The fourth Proviso states: “In order to ensure legal certainty for users, the scope of this Directive and the concepts relating to its application should be defined as precisely as possible”.

#### Improved applicability

- The criteria used for the nomination of Notified Bodies are more rigorous.
- Market surveillance. The obligations of the Member States are defined more accurately.
- Rules have been added for the withdrawal of dangerous products.

#### The conformity evaluation procedures have been revised

- It will no longer be possible to submit a technical file to a notified body without undergoing any verification of the content by the latter.
- Internal inspection of manufacturing process (Annex VIII) is required for all conformity evaluation procedures. Responsibility for inspection lies with the manufacturer.

#### **Note on the annexes listing dangerous machinery and safety-related components**

Annex 4 - which lists dangerous machinery and safety-related components – also includes safety-related logic blocks (e.g. programmable control units, PLCs, etc.). Annex 5 includes a non-exhaustive list of safety-related components.

## SAFETY IN THE WORKING ENVIRONMENT

### Certifications

- CE type examination certificates issued by notified bodies must be updated.
- The CE type certificates is valid for 5 years (Annex IX para. 9.3), the five-year period starting from the revision date of the certificate.

### LOW VOLTAGE DIRECTIVE

2006/95/EC is aimed at ensuring that electrical materials are designed and manufactured so as to guarantee the protection of people against any risk of injury arising from the use of such materials.

This Directive applies to all electrical materials meant for use at a nominal voltage of between:

- 50V and 1000V for alternating current.
- 75V and 1500V for direct current.

The last revision of the directive is in force starting from 16/01/2007.

### ELECTROMAGNETIC COMPATIBILITY DIRECTIVE

The aim of “Electromagnetic Compatibility Directive” 2004/108/EC is to ensure that electrical devices are designed and manufactured so that:

- Electromagnetic emissions are limited and low enough to permit other electrical devices to operate according to their intended purpose
- The level of built-in immunity to external disturbances enables them to operate according to their intended purpose.

This Directive applies to all electrical and electronic devices able to cause electromagnetic disturbances and whose operation can be affected by external factors.

The last revision of the directive is in force starting from 20/01/2005

### ATEX DIRECTIVE

**Atex DIRECTIVE 94/9/EC** applies to all products for use in explosive atmosphere.

The Directive specifies minimum safety requirements for electrical devices used in environments classified as dangerous regarding the aspect of risk of explosion from gas or dust.

The risk of explosion consists of three levels:

- Category 1 : maximum risk level (areas 0 and 20)
- Category 2 : high risk level (areas 1 and 21)
- Category 3 : risk level defined as “normal” (areas 2 and 22).

The ATEX Directive is in force since 1/07/2003.

# SAFETY IN THE WORKING ENVIRONMENT

## ACCREDITED BODIES

In each Member State, the role of the accredited Bodies is to assess and verify the compliance and the application of the Directives concerning machines and safety components.

Each State is responsible for the appointment and control of its own Bodies.

The Accredited Bodies must have the expertise and the resources which are necessary to perform their activities of inspection, analysis, technical support, measuring, etc.

## NOTIFIED BODIES

Notified Bodies are authorized to examine and certify machines and safety components in compliance with the applicable Directives.

Each Member State of the European Union is required to:

- Appoint the Notified Bodies by specifying their tasks
- Submit a list of the Notified Bodies to the European Commission and to the other Member States.

The European Commission publishes a Directory of all the Notified Bodies on the Official Journal of the European Commission, together with a list of the services, the machines and/or the safety components on which they are authorised to intervene.

The Member States of the European Union must make sure that these Bodies respect specified ethical and technical criteria.



## HARMONIZED STANDARDS

- They are technical Standards conceived to meet the essential requirements of the Directives
- They are written by the various technical committees on a mandate by the Commission of the European Union
- They are approved and adopted:
  - by the CEN (European Committee for Standardization)
  - or the CENELEC (European Committee for Electrotechnical Standardization)
- Then they are translated and published in the Official Journal of the European Committee and the Official Gazette of each Member State.

## Status of the Standards

**prEN...** a proposed standard (draft) which has not yet been definitely approved

**EN...** an approved standard already in force

**TS...** a technical specification.

## The European Standards concerning safety are subdivided into 3 groups:

### TYPE A STANDARDS

They specify the general design principles applying to all types of machine:

**e.g...** **EN ISO 12100** Safety of machinery - General principles for design - Risk assessment and risk reduction.

### TYPE B STANDARDS

They are divided into two classes:

- **type B1 Standards: concerning a specific aspect of safety**

**e.g...** **EN ISO 13855** Positioning of safeguards with respect to approach speeds of parts of the human body.  
**EN ISO 13857 - 1** Safety distances for the protection of the upper limbs.  
**EN 60204** Safety of machinery. Electrical equipment of machine.  
**EN ISO 13849 - 1,2** Safety related parts of control systems.

## SAFETY IN THE WORKING ENVIRONMENT

- **type B2 Standards: concerning safety devices**

e.g...	<b>EN 61496-1</b>	Electro-sensitive protective equipment - general requirements and tests-
	<b>EN 61496-2</b>	Electro-sensitive protective equipment- Particular requirements for equipment using active optoelectronics protective devices (i.e. light curtains)-
	<b>EN 61496-3</b>	Electro-sensitive protective equipment-Particular requirements for Active Optoelectronics Devices responsive to diffuse reflection (i.e. laser scanner)-
	<b>EN ISO 13850</b>	Emergency stop - Principles for design.

**TYPE C STANDARDS**

They concern specific types of machine:

e.g...	<b>EN 692</b>	Mechanical presses.
	<b>EN 693</b>	Hydraulic presses.
	<b>EN 415</b>	Packaging machines.
	<b>EN 415-4</b>	Palletizing and de-palletizing systems.
	<b>EN ISO 10218</b>	Industrial robot.

- A type C Standard takes priority over type A and B Standards.
- If no C type Standards exist, compliance with the Directive can be attained on the basis of type A and type B Standards.

**What is IEC TS 62046 – Application and integration of electrosensitive protection devices**

IEC TS 62046 Ed. 2 - 2008, specifies recommendations for the installation and use of Electro-sensitive Protective Equipment (ESPE).

It applies mainly to Light Curtains, Laser Scanners, Borders and pressure-sensitive mats. Its purpose is to meet machinery manufacturers' and users' needs.

IEC TS 62046 specifies the precise positioning of electrosensitive devices relative to the machine and their correct interfacing with the machine rather than their construction. Its goal is to ensure that the risk for the operator is minimized through a correct selection and application of protection devices.

IEC TS 62046 details crucial aspects linked to the use of ESPEs, such as selection criteria, use, integration with the machine control system and also provides information on special functions of safety light curtains including Muting and Blanking.

**NORTHERN AMERICAN STANDARD AND TEST BODIES**

The Body overseeing health and safety in the workplace in the USA is the **Occupational Health and Safety Administration (OSHA)**. Individual States may have their own safety regulatory organizations which may enforce stricter regulations than OSHA. OSHA oversees the application of laws and regulations in force at the Federal level, and in turn issues safety standards covering the use and construction of safety devices and/or machine tools.

An important example of such activity is Standard OSHA 1910.217 – Mechanical Power Presses.

The **American National Standard Institute (ANSI)** issues standards on the safety of machine tools or particular aspects of their construction or operation. For the preparation of these standards ANSI often relies on the contribution of non-profit organizations such as the **Robotic Industry Association (RIA)**, or the **Association for Manufacturing Technology (AMT)**.

**Examples of major ANSI standards:**

**B11 standards**, including:

- B11.1** Mechanical Power Presses
- B11.2** Hydraulic Power Presses
- B11.3** Power Press Brakes
- B11.4** Shears
- B11.19** Performance Criteria for the Design, Construction, Care and Operation of Safeguarding When Referenced by other B11 Machine Tool Safety Standards (design, construction, maintenance and operation criteria for protection devices specified in Std. B11 covering machine tools)

## SAFETY IN THE WORKING ENVIRONMENT

### Other ANSI standards:

- B20.1** Conveyor Belts
- ANSI/RIA R15.06** Safety Requirements for Industrial Robots.

Contrary to Europe, North America does not accept a certificate of conformity as an approval to sell and install electrical equipment.

Prior to installation the device or system in question must be inspected by the Authorities Having Jurisdiction (AHJ).

If the device in question is already listed by a Nationally Recognized Testing Laboratory (NRTL), the competent authority is dispensed from inspecting the product. The mark of a NRTL assures product conformity to safety standards in force.

Although not mandatory in North America, certification facilitates marketing as retailers, inspectors, users and local authorities readily approve any product bearing a NRTL mark. Certified installations enjoy advantages in terms of insurance benefits and freedom from potential industrial disputes, as workers unions might prevent members from operating non-certified, and therefore possibly dangerous, machinery.

OSHA is the body authorized to approve NRTLs.

NRTLs shall obtain approval for all national and foreign facilities for all products for which they are authorized to award certification. To obtain accreditation, the applicant shall also, but not only, prove to be independent of any users, suppliers or retailers of the products for which certification is sought. NRTLs may develop and apply for approval of its own developed standards or adopt standards produced by other NRTLs. Each NRTL has its own unique mark.

**Underwriters Laboratories Inc. (UL)** is a leading NRTL among those authorized to issue certification of electrical systems and equipment. UL is a non-profit organization listing industrial components which have been tested and proven to be safe and reliable in terms of electrical safety and fire resistance.



UL Listed Certification Mark means that the product in question was tested and verified to be in line with USA safety requirements. UL Listed General Mark certifies conformance to fire resistance and electrical safety requirements.



UL certification also includes components such as safety light curtains which are covered by Std. UL 61496-1 and Std. UL 61496-2 derived from international Std. **IEC 61496-1,2**. Systems incorporating safety software can be also certified as per Std. **ANSI/UL 1998**. Safety light curtains (ESPE) are covered by a specific marking certifying compliance with the appropriate product standard and with Std. ANSI/1998. Reer safety curtains are in line with all these requirements and bear the associated mark of approval.



UL may also certify conformity to CSA Canadian Standards (through C-UL mark or C-UL-US mark for products to be marketed in Canada and in the USA).

The **Canadian Standard Association (CSA)** is the main Canadian standardization body and acting certification authority competent for verification of conformance of safety components to Canadian regulations. As Nationally Recognized Test Laboratory (NRTL) for the USA, CSA is authorized to verify conformance of all products under OSHA jurisdiction and award the CSA mark of NRTL/C, equivalent to C-US UL, which applies for example to safety light curtains.



## SAFETY IN THE WORKING ENVIRONMENT

**RISK ASSESSMENT**

The European Standard **EN ISO 12100** puts forward a systematic procedure for the examination of the hazards associated with machinery with the aim of selecting and adopting the most suitable safety measures to reduce or eliminate the risks.

For USA an equivalent procedure is described in the **ANSI Technical Report B11.TR3**.

**The risk assessment can thus be broken down into 4 stages:**

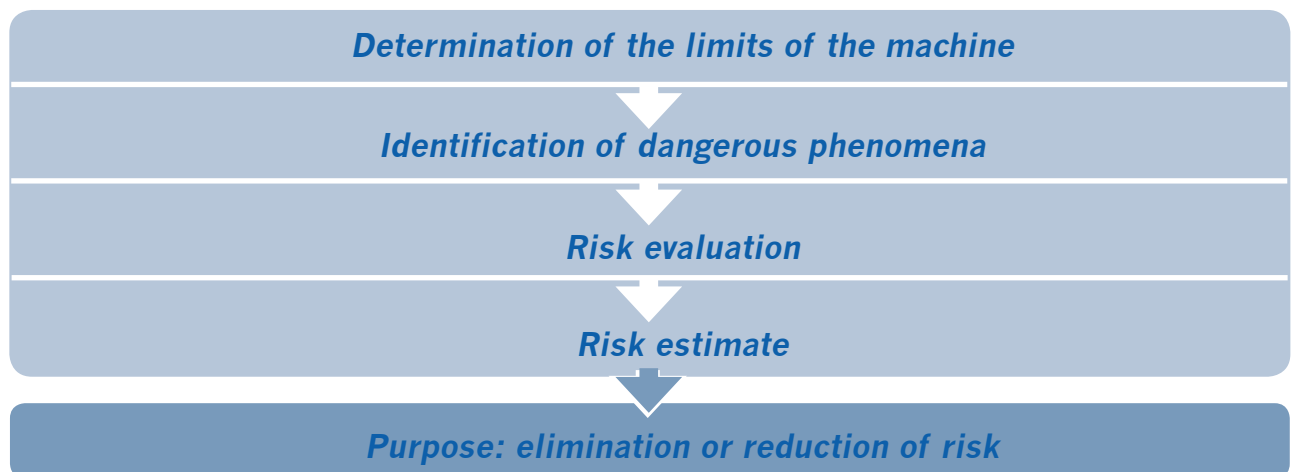

Fig. 1 - Stages of risk assessment

### 1. Determination of the limits of the machine

Consists in the examining of the intended use and of all the reasonably foreseeable misuses in relation to the level of training, experience and attitude of the user.

### 2. Identification of the hazards

Consists in the listing of:

The risks and the hazardous elements (mechanical, electrical, chemical, etc.)

Hazardous situations (manual loading-unloading, access to the system, etc.)

Events that might cause damages (machine failures or anomalies).

### 3. Risk estimation

Each hazardous situation identified is derived from a combination of the following elements:

Severity of injuries or damage to health (reversible, irreversible, fatal)

Probability of occurrence of that injury, which is a function of frequency and duration of exposure to danger

Possibility of avoiding danger with reference to:

- rapidity of occurrence of the event,
- possibility by the operator to perceive hazards and react promptly,
- possibility to escape.

### 4. Risk evaluation

Following the risk estimation a risk evaluation is required to determine if a risk reduction is necessary or whether safety has been achieved. If risk reduction is required, the protective measures selected and applied shall be evaluated to determine if an adequate risk reduction has been achieved.

# SAFETY IN THE WORKING ENVIRONMENT

## SAFETY-RELATED CONTROL SYSTEM FOR MACHINERY

Where safety is based on the proper operation of the machine control system, it shall be designed so that to ensure a minimal probability of functional errors. Otherwise, any errors shall not lead to the loss of the safety function. In Europe, to meet these requirements it is highly recommended to use the harmonized standards developed by mandate of the European Commission (assumption of conformity).

In the event of an accident, using the harmonized standards saves extra time and costs where proof of conformity of the safety-related control system to the essential requirements of the Machinery Directive shall be demonstrated.

Given hereunder are the basic concepts of the new standards ISO 13849-1 and IEC 62061 which supersede EN954-1 as regulatory instruments covering machine control systems.

### The old EN 954-1 Safety Related Parts of Control Systems, Part 1: General principles for design.

Up to December 31, 2011, safety-related parts of the machine control system designed according to Std. EN 954-1 shall be acceptable. As from 31st December 2011, compliance with Std. ISO 13849-1 or IEC 62061 will be mandatory.

Standard **EN 954-1** is harmonized since 1996. The safety-related control system is classified in five Categories.

### Safety categories

For different parts of the machine the risk evaluation may lead to different levels. Therefore, the degree (category) of safety actions to be taken shall depend on the actual risk involved in each part.

To select the optimum category in relation to actual risk, use shall be made of the well-known risk graph.

### Selection of the Categories

#### S Severity of injury

**S1** Slight injury (usually reversible).

**S2** Serious injury (usually irreversible) or death.

#### F Frequency and duration of exposure to hazard

**F1** Seldom to more often and/or short exposure.

**F2** Frequent to continuous and/or long exposure duration.

#### P Possibility of Avoiding hazard

**P1** Possible under certain conditions (escape or action by others).

**P2** Hazard almost unavoidable (occurs quickly).

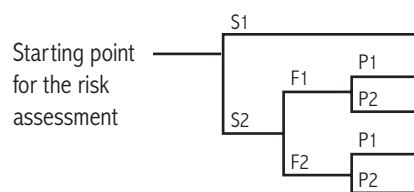
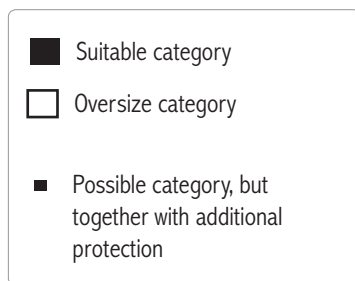

TABLE FOR CATEGORY SELECTION

Categories				
B	1	2	3	4
■	■	□	□	□
■	■	■	□	□
	■	■	■	□
	■	■	■	□
	■	■	■	■

Fig. 2 - Category selection

For Cat. B and Cat.1 the ability to resist failure is due to robustness of components (avoid failures as far as possible).

For Cat. 2,3,4 the ability to resist failure is due to the system structure (control of the failure). Failure is controlled through cycle monitoring for Cat.2, redundancy for Cat.3, redundancy plus monitoring for Cat.4.

Operational requirements are specified for each Category. The failure modes of the electric components are defined and listed. The relationship among Categories and the safety performance of the control system in case of failure is well defined (deterministic approach).

Note: categories are not necessarily totally hierarchical.

# SAFETY IN THE WORKING ENVIRONMENT

CATEGORY	REQUIREMENTS	BEHAVIOUR	SAFETY PRINCIPLES
<b>B</b>	Devices designed, manufactured and combined in compliance with the reference Standards so as to be able to cope with foreseeable events.	A fault may result in the loss of the safety functions.	Use of selected components.
	Same requirements as for category B, but with the use of reliable and well-tested safety principles and components.	A fault may result in the loss of the safety functions, but with lower probability than in category B.	
<b>1</b>	The requirements of category 1 apply. Moreover: the safety function of the device is based on cyclic control managed by the control system of the machine.	A fault may result in the momentary loss of the safety function. The fault is detected when performing the test before starting the next working cycle, and the start of a new machine cycle is disabled.	Use of structures and safety circuits able to detect the fault and stop the machine.
<b>2</b>	The requirements of category 1 apply. Moreover: a single fault shall not lead to the loss of the safety function. Whenever possible, the individual fault must be detected.	Not all faults can be detected. When an individual fault occurs, the safety function is always active. The build up of undetected faults may result in the loss of the safety function.	
<b>3</b>	The requirements of category 1 apply. Moreover: a single fault shall not result in the loss of the safety function. An individual fault is detected before or at the time of the request for the safety function. If this is not possible, the build up of faults shall not lead to the loss of the safety function.	Fault detection shall occur in time to prevent the loss of the safety function.	
<b>4</b>			

## Restricted use of EN 954-1

System behaviour upon failure cannot be the only way to assess the performance of the safety-related control system.

Other factors, such as component reliability, may have an important, even crucial, role.

Such concept is recognized in Std. EN 954-1 stating that (Annex B) “component reliability and the technology used in the application concerned may result in deviation from the Category envisaged.”

The Category selection process should be as follows:

- Identify the nominal or reference Category based on risk analysis (through risk graph)
- Modify selection of Category based on component reliability, technology used, etc.



## SAFETY IN THE WORKING ENVIRONMENT

Phase two of the process is mainly empirical, and little information is given in the Standard.

Category is almost invariably selected referring to the risk graph disregarding changes due to other factors, or the changes introduced are subjective to the point where proving system safety becomes difficult.

Also, the extensive use of programmable electronics in the field of machine control systems has further highlighted the shortcomings of the deterministic model, impracticable for complex control systems, i.e. systems which use PLCs, communication lines, variable-speed actuators and programmable sensors.

To evaluate the safety-related performance of a complex system it is better to estimate its probability of being able to provide protection when needed. Or, in other words, estimate the probability of occurrence of a dangerous failure in a given period of time considering component reliability.

### The new Standards

To offset the applicability limitations of Std. EN 954-1 two new standards were adopted, namely ISO 13849-1:2006 and IEC 62061:2005 which combine probability and known deterministic concepts to cope with technological progress in the field of industrial machinery.

Both these standards are harmonized to Directive 2006/42/EC regarding the following mandatory safety requirement:

Annex I : 1.2 Controls systems.

The two Standards exhibit a number of differences and overlaps, especially as regards the application criteria.

ISO 13849-1 may be used regardless of the type of technology and power used, i.e. mechanical, hydraulic, pneumatic, electric. It applies only to the five designated architectures.

IEC 62061 applies only to electric powered control systems. Subsystem reliability calculation formulas are given only for the four types of architecture specified therein and considered typical of industrial machinery, but may be applied also to other architectures. It allows the integration of subsystem designs in line with the requirements of ISO 13849-1: 1999 (EN 954-1).

### ISO 13849-1 Safety Related Parts of Control Systems, Part 1: General principles for design

ISO 13849-1 is a revised version of EN 954-1

The complex mathematical formulas of the system reliability theory were replaced with pre-calculated tables.

Some concepts of EN 954 were retained, i.e. categories, redundancy, monitoring.

A number were modified, i.e. risk graph, selection of Categories.

The role of Categories is no longer crucial as in EN 954-1.

To assess the resistance to dangerous failure, the Category concept is replaced by Performance Level (PL) as the ability of the safety-related machine control system (hereinafter called SRP/CS) to assure protection in specified operating conditions.

The parameter used to evaluate the PL of the safety-related system is the Average probability of dangerous failure/hour. A failure is considered to be dangerous where it inhibits the system protection function if undetected.

**SAFETY IN THE WORKING ENVIRONMENT**

There are 5 levels, PLa to PLe.

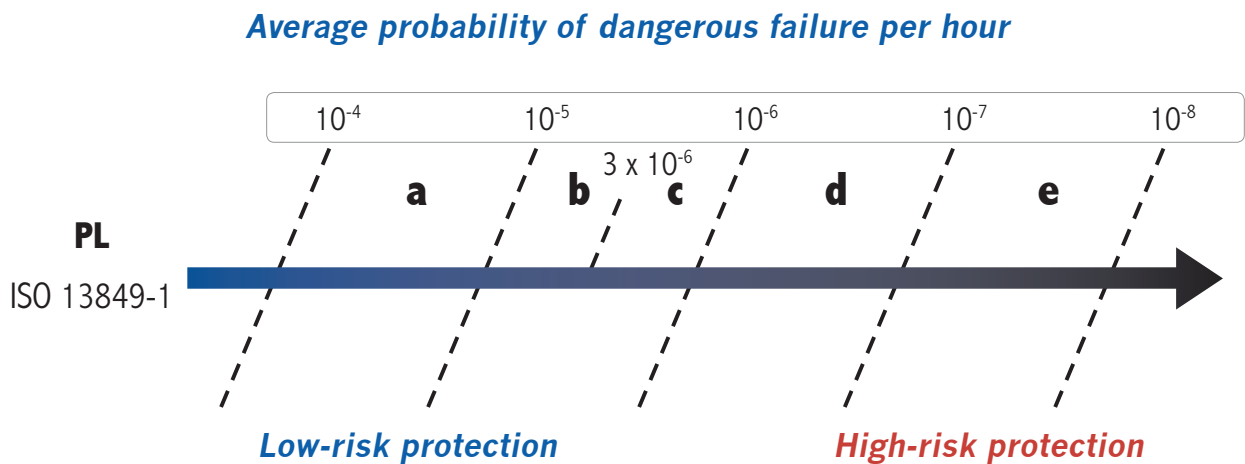

Fig. 3 - Table of ISO 13849-1

The greater the contribution to reducing risk the lower the **Average probability of dangerous failure/hour**.

PL is a function of control system architecture, component reliability, ability to promptly detect internal failure potentially affecting the safety function and quality of the design.

The table below summarizes mandatory qualitative and quantitative requirements to be met for safe control system design to ISO 13849-1.

► **See also glossary on page 28**

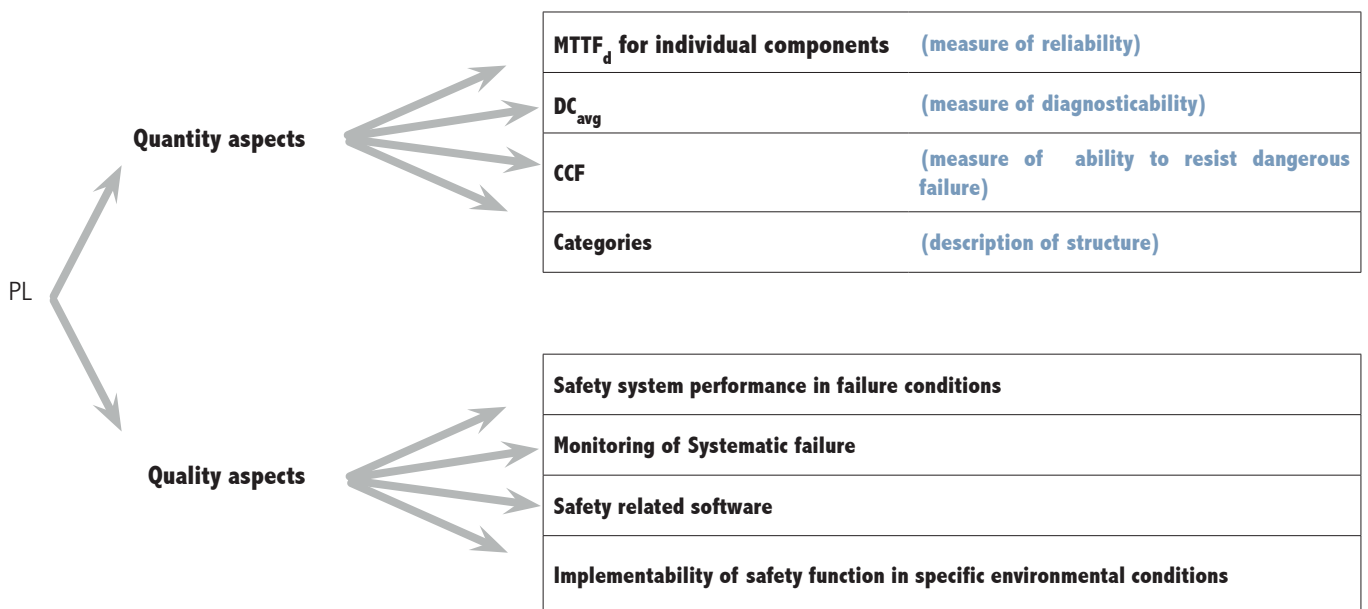

Fig. 4 - Mandatory qualitative and quantitative requirements to be met for safe control system design to ISO 13849-1

## SAFETY IN THE WORKING ENVIRONMENT

To claim a given PL, in addition to evaluating the Average probability of dangerous failure/hour for the control system in question, it will also be necessary to prove compliance with quality requirements specified by the standard.

The claimed PL must be validated using ISO 13849-2 Safety Related Parts of Control Systems - Validation defining procedures tests and analysis, for the assessment of:

- Safety function provided
- Category attained
- Performance level reached.

### IMPORTANT!

Average Probability of Dangerous Failure/Hour is only one of the parameters contributing to assignment of PL.

To obtain a PL rating, it is also mandatory to prove and substantiate having considered and complied with all requirements, including:

- Monitoring of systematic failures
- Using robust and reliable components (in line with Product Standards if available)
- Working according good engineering practice
- Considering environmental conditions in which the safety-related system will operate
- In the case of new software, adopting all organisational aspects of V-type development model shown in Figure 6 of the Standard ISO 13849-1 and meeting development requirements for applications and built-in SW.

Design of an SRP/CS as per ISO 13849-1 may be summarized in the following eight steps:

1. Identification of safety-related function through risk analysis
2. Assignment of Performance Level requested (PLr) through risk graph
3. Selection of system structure (architectures) and self-diagnostic techniques
4. Technical development of control system
5. Calculation of MTTFd, DCavg and verification of CCF
6. Calculation of PL using Table 5
7. Verification of PL (if calculated PL is below PLr return to Step 3)
8. Validation.

### Identification of safety related item and assignment of Performance Level required - PLr

For each safety-related function identified the designer of the SRP/CS decides the contribution to reduction of risk to be provided, i.e. PLr.

This contribution does not cover overall machine risk but only the part of risk related to the application of the safety function in question.

Parameter PLr represents the Performance Level required for the safety-related function in question.

Parameter PL represents the Performance Level of implementation hardware. PL of hardware must be equal to or higher than specified PLr.

A tree type graph of decisions is used to find the contribution to risk reduction that must be provided by the safety-related function, leading to univocal identification of PLr. If more than one safety-related function are identified, PLr shall be identified for each of them.

## SAFETY IN THE WORKING ENVIRONMENT

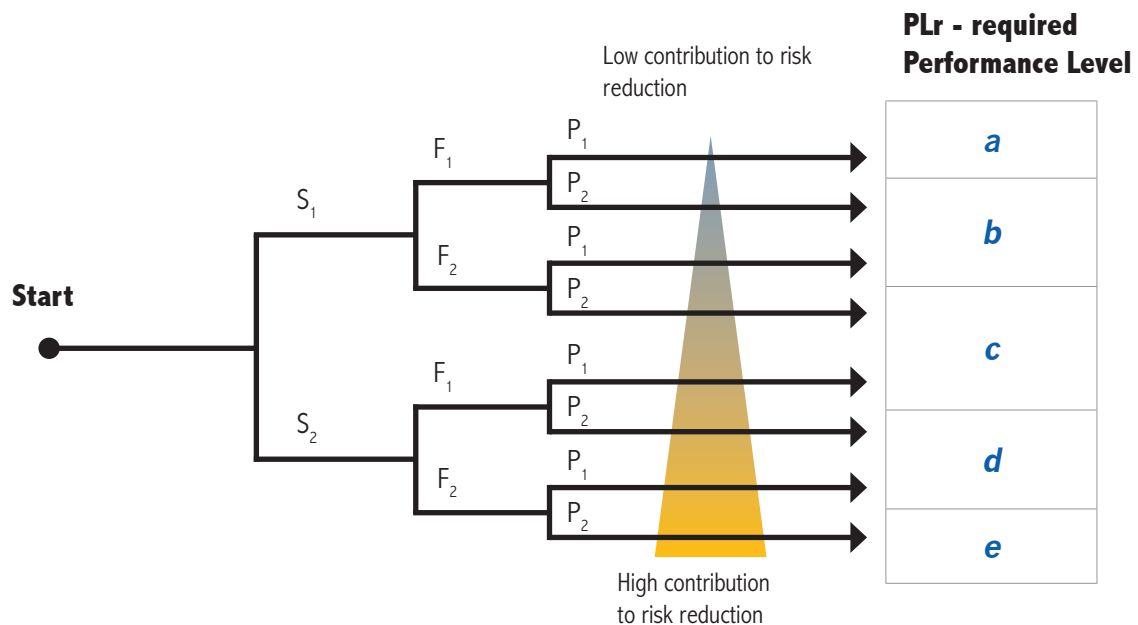

Fig. 5 - Tree type graph of decisions

#### S severity of injury

**S1** reversible

**S2** irreversible

#### F frequency or time exposure to hazard

**F1** rare / short

**F2** continuous / prolonged

#### P avoidable risk or limitation of damage

**P1** avoidable within given conditions

**P2** almost unavoidable

**Note:** contrary to EN954-1 as regards Categories, here PLRs are totally "hierarchical".

PLr(e) provides the greatest contribution to risk reduction, whereas PLr(a) makes the lowest contribution.

### Design of the safety related control system and evaluation of the PL

After deciding on the PLr needed, a suitable SRP/CS is designed, calculating the resulting PL and ensuring that it is higher than or equal to PLr.

Fig. 3 shows that, to obtain the PL, the Average probability of dangerous failure/hour of the SRP/CS designed must be calculated

The Average probability of dangerous failure/hour for a safety-related control system may be estimated in various ways.

Using such methods implies that for each components the following are known:

- Failure rate ( $\lambda$ )
- Percent distribution of failure rate for all component failure modes, (e.g. if for a positive action switch the failure modes are: the contact will not open when required = 20% of cases and the contact will not close when required = 80% of cases).
- The effect of each failure on safety-related system performance, (e.g. dangerous failure =  $\lambda d$ , or non-dangerous failure =  $\lambda s$ )
- Percent of dangerous failures detected (by automatic self-diagnostic techniques implemented) out of total dangerous failures:  $\lambda_{dd} = \lambda d \times DC$ .
- Percent of dangerous failures not detected (by automatic self-diagnostic techniques implemented) out of total dangerous failures:  $\lambda_{du} = \lambda d \times (1-DC)$ .

## SAFETY IN THE WORKING ENVIRONMENT

ISO 13849-1 simplifies calculation by providing a table based on Markov modelling in which average probability of dangerous failure per hour is pre-calculated for various Category combinations and range values of MTTFd and DCavg which are in turn obtained using tables.

Denotations of MTTF <sub>d</sub>	Range of MTTF <sub>d</sub>	Denomination DCavg	Range of values DC / DCavg
Low	3 years ≤ MTTF <sub>d</sub> < 10 years	None	DC < 60%
Medium	10 years ≤ MTTF <sub>d</sub> < 30 years	Low	60% ≤ DC < 90%
High	30 years ≤ MTTF <sub>d</sub> < 100 years	Medium	90% ≤ DC < 99%
		High	99% ≤ DC

The problem is thus reduced to: selecting the architecture, calculating DC<sub>avg</sub> in relation to self-diagnostic techniques implemented, calculating simplified MTTF<sub>d</sub> of circuit designed and verifying compliance with requirements for independent channel operation (CCF) for redundant architectures (Cat. 2, 3 and 4).

The combination of Category plus DC<sub>avg</sub> adopted, is shown in one of the seven columns of fig. 5 of ISO 13849-1. Calculated MTTF<sub>d</sub> determines which part of the column is to be considered. Corresponding PL is shown on the left of the table.

Fig. 6 - figure of ISO 13849-1

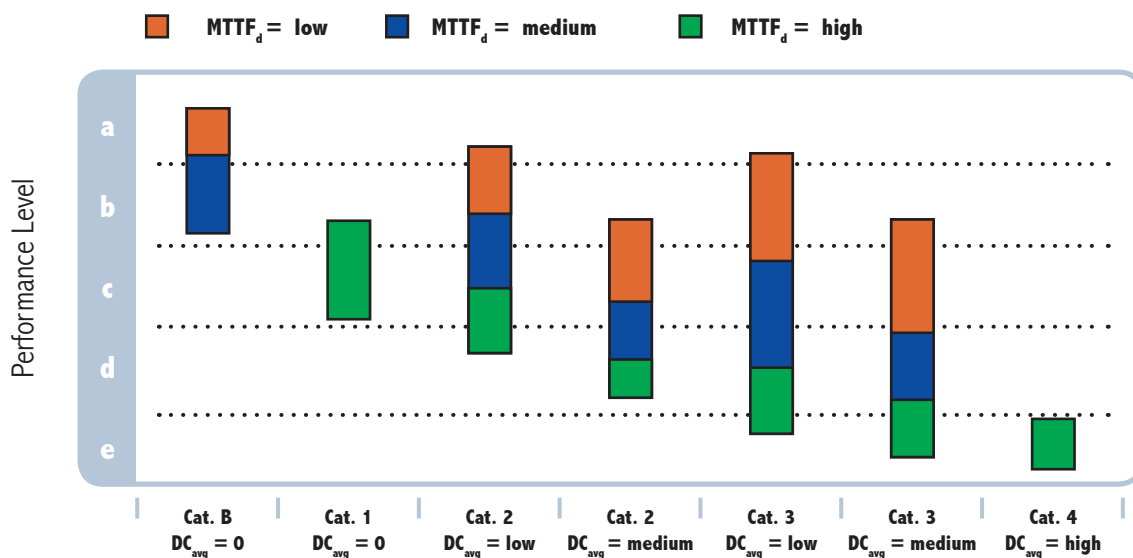

The part of column selected may include two or three possible values of PL, e.g. for Cat. 3, DC<sub>avg</sub> = Medium and MTTF<sub>d</sub> = Low, the following three values are possible: PLb, PLc, PLd. In these cases, to obtain the correct PL use is made of Table K.1 of Annex K of the Standard (not shown) providing detailed values of Average probability of dangerous failure per hour and PL in relation to actual value of MTTF<sub>d</sub> and the combination Category-plus-DC<sub>avg</sub> implemented.

The Standard may be adopted only if the control system is designed using one (or more) of the five architectures specified.

Each architecture corresponds to one of the Categories defined in EN 954-1.

For systems designed to EN 954-1, category selection is directly linked to risk through the risk graph.

ISO 13849-1 is more flexible, as several options are available for each Performance Level specified.

An example is given in Table 5 where for a system having PL of "c" the following five alternatives are possible:

1. Category 3 with MTTF<sub>d</sub> = Low and DC<sub>avg</sub> medium.
2. Category 3 with MTTF<sub>d</sub> = Medium and DC<sub>avg</sub> low.
3. Category 2 with MTTF<sub>d</sub> = Medium and DC<sub>avg</sub> medium.
4. Category 2 with MTTF<sub>d</sub> = High and DC<sub>avg</sub> low.
5. Category 1 with MTTF<sub>d</sub> = High.

## SAFETY IN THE WORKING ENVIRONMENT

**Combination of several SRC/PS to achieve the overall PL**

The safety-related function may include one or more SRP/CSs, and several safety-related function may use the same SRP/CSs.

Individual SRP/CSs could also be obtained using other architectures.

Where the safety-related function is obtained by a series connection of several SRP/CSs, e.g. safety light curtains, control logics, power output, and for each of these the PL is known, the Standard provides a simple method for calculating overall PL.

Locate the part with PL = PL low

Find the number of parts having PL = PL low

Enter data in the following table to obtain total PL

PL (low)	n (low)		PL
<b>a</b>	>3	-->	-
	≤ 3		<b>a</b>
<b>b</b>	>2	-->	<b>a</b>
	≤ 2		<b>b</b>
<b>c</b>	>2	-->	<b>b</b>
	≤ 2		<b>c</b>
<b>d</b>	>3	-->	<b>c</b>
	≤ 3		<b>d</b>
<b>e</b>	>3	-->	<b>d</b>
	≤ 3		<b>e</b>

The PL obtained using this table refers to reliability values at mid-position for each of the intervals in Table 3 of ISO 13849-1.

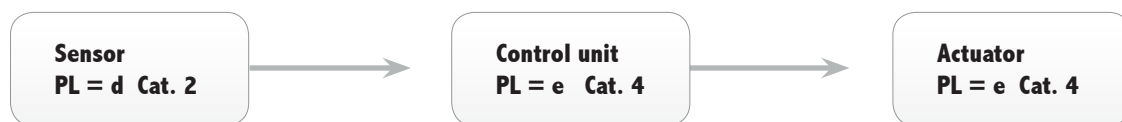
**Example:**

We have: **PL low = d**      **N low = 1 (< 3)**

Therefore: **PL total = d**

and average probability of dangerous failure per hour for the entire system will be a number somewhere between  $1 \times 10^{-6}$  and  $1 \times 10^{-7}$  (see Table 3 of ISO 13849-1).

### IEC 62061      **Safety of machinery – Functional safety of safety-related electrical, electronic and programmable electronic control system.**

IEC 62061 is derived from IEC 61508 – Functional safety of safety-related electric/electronic/programmable electronic control systems.

**Note:** IEC 61508 is the international reference standard on functional safety of electric, electronic and programmable electronic systems. The Standard consists of seven sections. The first three sections specify the safety requirements for hardware and software, the rest are of an informative nature and offer support for the correct application of the former.

IEC 62061 retains the features of IEC 61508, but simplifies safety requirements (of both hardware and software) adapting them to the specific needs of industrial machinery.

Safety requirements are considered only for “high demand mode”, i.e. request of the safety function more than once per year.

The standard is based on two basic concepts:

- Management of Functional Safety
- Safety Integrity Level.

# SAFETY IN THE WORKING ENVIRONMENT

## Management of Operational Safety

Specifies all design aspects needed to attain the required level of functional safety, from assignment of safety requirements to documentation, design management up to validation.

Each design shall have its own Functional Safety Plan properly written, documented and duly updated as necessary.

The Functional Safety Plan shall identify people, functions and resources needed for design and implementation of the safety system.

## Safety Integrity Level (SIL )

Methodology and requirements is given for:

- specifying functional requirements of each safety-related function to be implemented
- assigning the Safety Integrity Level (SIL) for each safety-related function envisaged
- allow the design of a SRECS suitable for the safety-related function to be implemented
- validating the SRECS.

## SIL assignment

For SIL assignment use the method of Annex A (although the Standard also accepts the techniques of IEC 61508-5).

For each risk identified the following must be assessed:

- Degree of severity (Se) of possible damage
- Frequency and time (Fr) of exposure to danger
- Probability of dangerous event (Pr) linked to machine operating mode
- Avoidability (Av) of danger. The more difficult to avoid danger the higher the number representing avoidability.

The following table, extracted from the form in Figure A.3 of the Standard IEC 62061, will help in obtaining the SIL to be assigned to the safety-related function.

Consequences	Severity Se	Class Cl					Frequency and duration Fr	Probability of hazardous event Pr	Avoidance Av			
		4	5-7	8-10	11-13	14-15						
Death, losing an eye or arm	4	SIL 2	SIL 2	SIL 2	SIL 3	SIL 3	≥ 1 hour	5	Very high	5		
Permanent: losing fingers	3		OM	SIL 1	SIL 2	SIL 3	< 1 hour ≥ 1 day	5	Likely	4		
Reversible: medical attention	2			OM	SIL 1	SIL 2	< 1 day ≥ 1 2 weeks	4	Possible	3	Impossible	5
Reversible: first aid	1				OM	SIL 1	< 1 2 weeks ≥ 1 1 year	3	Rarely	2	Possible	3
							< 1 1 year	2	Negligible	1	Probable	1

OM (Other Measures) = The use of other parameters is recommended.

The sum of marks obtained for attributes of frequency, probability and avoidability provides the probability class of danger:

$$Cl = Fr + Pr + Av$$

To obtain the SIL align actual Cl to level of severity (Se) identified.

This is an iterative process. In fact, depending on the protective action undertaken, some parameters might change, e.g. Fr or Pr, in which case the SIL assignment process will have to be repeated using new values for changed parameters.

Three levels are envisaged: **SIL 1**, **SIL 2**, **SIL 3**.

## SAFETY IN THE WORKING ENVIRONMENT

Average probability of serious failure per hour (PFH<sub>d</sub>)

Fig. 7 - Table 3 of IEC 62061

Thus, the SIL represents the safety level to be assigned to a SRECS for attainment of its safety integrity in the operating conditions and all the way through the time specified.

The parameter used to define the SIL (Safety Integrity Level) is the probability of dangerous failure/hour (PFH<sub>d</sub>).

The higher the SIL, the lower the probability of the SRECS not performing as safely as expected.

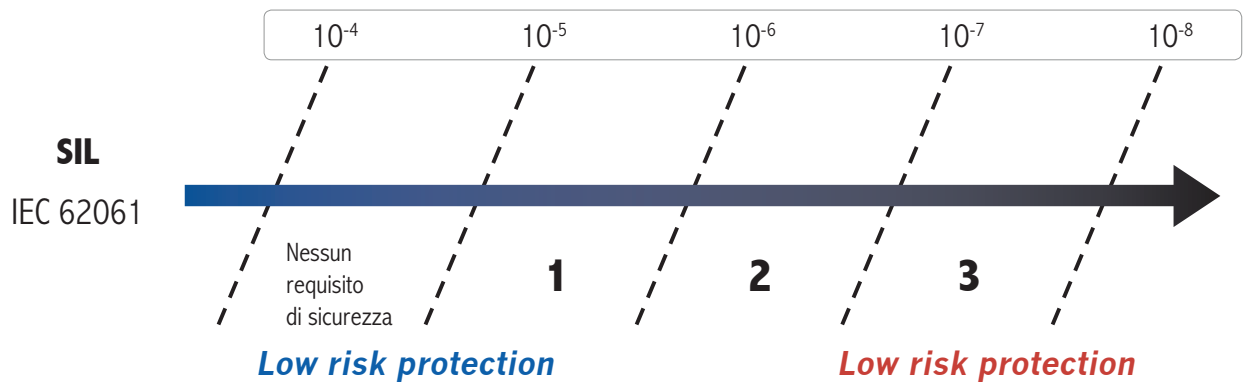
The SIL must be defined for each safety-related function resulting from risk analysis.

### Development and design process

Each safety-related function identified through risk analysis shall be described in terms of:

- Operational requirements (mode of operation, cycle time, environmental conditions, response time, type of interface with other components or items, EMC level, etc.)
- Safety requirements (SIL).

Each safety-related function shall be broken down into functional blocks, e.g. functional block of input data, functional block of logic data processing, functional block of output data.

A subsystem is associated with each functional block.

In turn, subsystems will consist of electrical components interconnected with one another. Electrical components are known as subsystem elements.

Implementation of the SRECS technique will result in a typical architecture as shown (in this instance access control through photoelectric curtain)

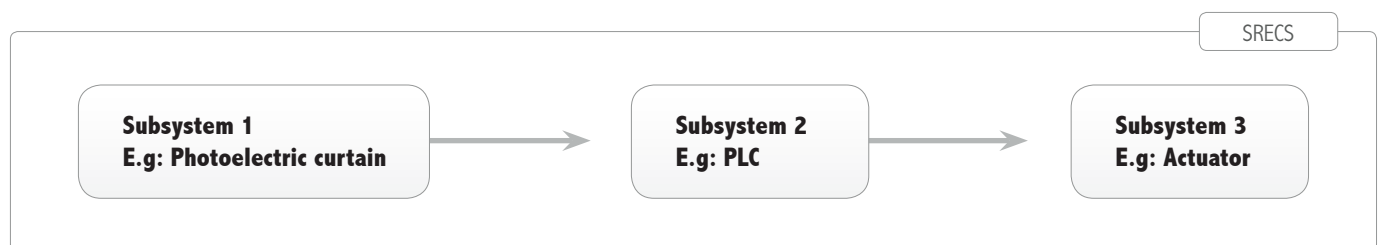
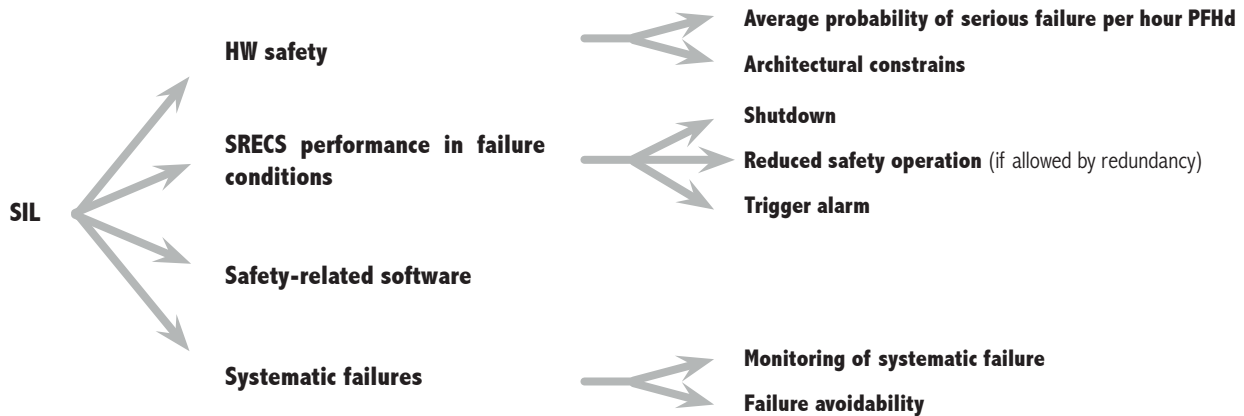

Fig. 8 - Typical architecture of the SRECS



# SAFETY IN THE WORKING ENVIRONMENT

For SRECS to comply with identified operational and safety requirements, the following requirements shall be met:



Each subsystem shall consist of electrical circuits suited to attain the required SIL.

The maximum SIL attainable by a subsystem is identified as SILCL (SIL claim).

Subsystem SILCLs depend on  $PFH_d$ , architecture constraints, performance under failure conditions and on the ability to control and avoid systematic failure.

## Safety-related software

For software design, the code must be developed as per reference standards depending on the type of software in question as follows:

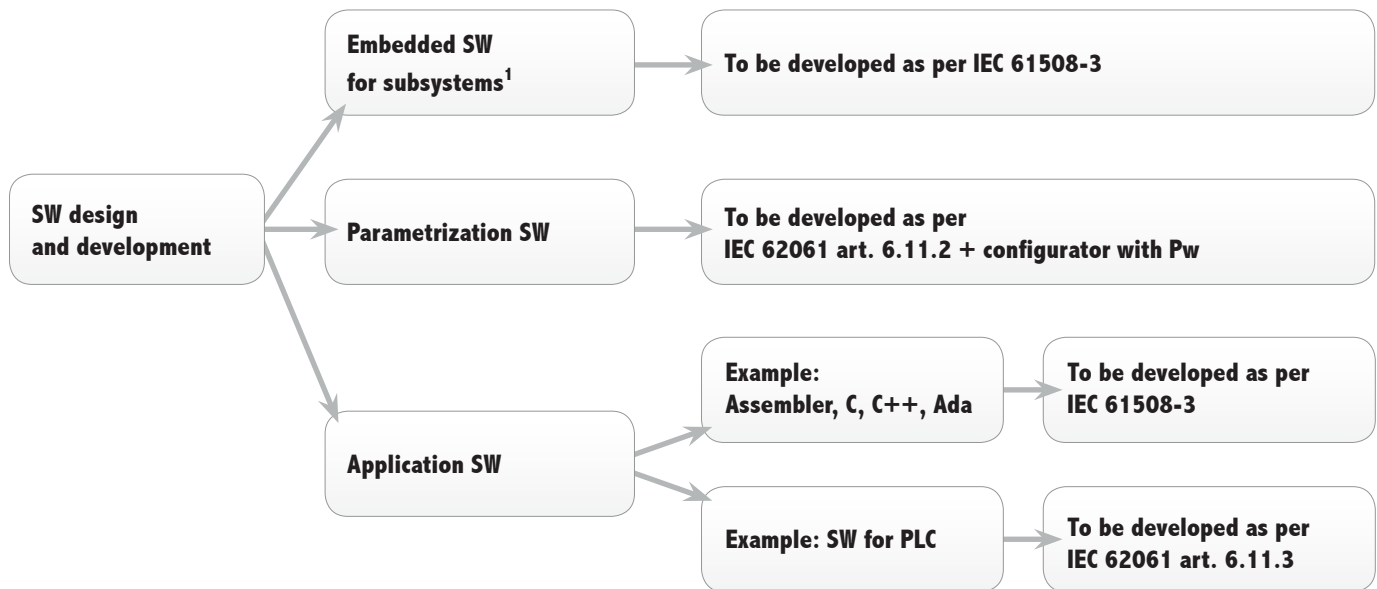

**Note:** Safety-related PLCs, safety bus, actuators, safety light curtains and in general all complex safety-related devices with integral programmable logics and embedded software, if used to build a SRECS, shall comply with the requirements of the appropriate Product Standards (if applicable) and with IEC 61508 as regards functional safety.

## SAFETY IN THE WORKING ENVIRONMENT

**IMPORTANT!**

The probability aspect is only one of the elements contributing to assignment of SIL.

To claim a specific SIL applicants must prove and document having:

- adopted adequate management actions and techniques to attain the required level of operational safety
- in place a documented and up-to-date Operational Safety Plan
- avoided systematic failure as far as possible
- evaluated (through inspections and tests) safety system performance in actual environmental conditions
- developed the software after adopting all organisational aspects required.

**Calculation of subsystem PFH<sub>d</sub>**

To calculate subsystem PFH<sub>d</sub> select first the type of architecture (structure). The Standard suggests four pre-defined architectures, providing a different simplified formula for each of them.

This calculation requires the use of the following parameters:

- λ<sub>d</sub>** = Dangerous failure rate of each subsystem element.  
Obtained from its known failure rate λ, percent distribution of failure rate for all failure modes and analysis of subsystem performance after failure (Dangerous Failure = λ<sub>d</sub> or Non-dangerous Failure = λ<sub>s</sub>).
- T1** = Proof Test. Proof test interval (external inspection and repair returning the system to as-new condition) for industrial machinery usually coincides with life time (20 years).
- T2** = Test interval of the diagnostic functions. Depending on design or devices used the diagnostic functions can be executed by internal circuitry of the same SRECS or by other SRECSs..
- DC** = Diagnostic Coverage:  
Parameter representing the percent of dangerous failures detected out of all possible dangerous failures.  
DC depends on self-diagnostic techniques implemented.  
Assuming that failure is always possible (otherwise there would be no point in defining λ), that mechanisms for detecting failures are not necessarily all equally effective and responsive (depending on type of failure some may take longer), that it is impossible to detect all failures, that suitable circuitry architectures and effective testing may permit detection of most dangerous failures, a DC parameter may be defined for estimating the effectiveness of implemented self-diagnostic techniques.  
IEC 62061 does not provide data for obtaining DC in relation to implemented diagnostic techniques. However, data of IEC 61508-2 Annex A may be used.
- β** = Common cause failure factor. Provides a measure of the degree of independence of operation of redundant channel systems.

Having calculated subsystem PFH<sub>d</sub> by means of the formulas from the IEC 62061, it is important to ensure that the associated SILCL obtained from Table 3 of IEC 62061 (see page 21) is compatible with the constraints imposed by the architecture as the maximum SILCL attainable by a given subsystem is restricted by the hardware fault tolerance of the architecture and by SFF as listed in the following table

(Table 5 of IEC 62061)

Safe failure fraction (SFF)	Hardware fault tolerance		
	0	1	2
SFF < 60%	Not allowed	SIL 1	SIL 2
60% ≤ SFF < 90%	SIL 1	SIL 2	SIL 3
90% ≤ SFF < 99%	SIL 2	SIL 3	SIL 3
SFF ≥ 99%	SIL 3	SIL 3	SIL 3

## SAFETY IN THE WORKING ENVIRONMENT

Subsystem safety failure fraction (SFF) is, by definition, the fraction of overall failure rate not involving dangerous failure

$$SFF = (\Sigma\lambda_s + \Sigma\lambda_{dd}) / (\Sigma\lambda_s + \Sigma\lambda_{dd} + \Sigma\lambda_{du}).$$

$\lambda_{dd}$  (failure rate of detectable dangerous failures) and  $\lambda_{du}$  (failure rate of undetectable dangerous failures) are obtained from known effectiveness of implemented diagnostic techniques.

If  $PFH_d$  and SILCL of each subsystem are known, it will be possible to calculate the overall SIL of SRECS.

The overall probability of dangerous failure/hour of SRECS will equal the sum of the probabilities of dangerous failure/hour of all subsystem involved and shall include, if necessary, also the probability of dangerous failure per hour (PTE) of any safety-related communication lines:

$$PFH_d = PFH_{d1} + \dots + PFH_{dN} + P_{TE}$$

Known the  $PFH_d$ , the resulting SIL of the SRECS is obtained from Table 3.

The SIL shall than be compared to the SILCL of each subsystem, as the SIL that can be claimed for the SRECS shall be less or equal to the lowest value of the SILCL of any of the subsystems.

### Example:



$$PFH_d(\text{system}) = PFH_d(ss1) + PFH_d(ss2) + PFH_d(ss3) + P_{TE} = 5,56 \times 10^{-7}/h$$

$$SIL = 2$$

Where a subsystem involves two or more safety-related functions requiring different SILs, the highest SIL shall apply.

## CONCLUSIONS

The procedures specified in EN ISO 13849-1 simplify the estimation of Average Probability of Dangerous Failure per Hour compared to IEC 61508, offering a pragmatic approach more in line with the needs of the machine tool industry.

By retaining Categories and other basic concepts, such as safety-related function and risk graph, seamless continuity with EN 954: 1996 is assured.

Maintaining a closely linear approach with EN 954-1:1996 however, shows the limits of EN ISO 13849-1 / EN 954-1. Where the adoption of complex technology is anticipated, e.g. programmable electronics, safety-related bus applications, different architectures, etc., it will be more appropriate to design to IEC 62061.

Where devices and/or subsystems designed in accordance with EN ISO 13849-1 are used, Std. IEC 62061 shows how to integrate them in SRECS.

## SAFETY IN THE WORKING ENVIRONMENT

A precise bi-univocal equivalence between PL and SIL cannot be identified.

However, the probabilistic side of PL and SIL can be compared as they use the same concept, namely the Average Probability of Dangerous Failure per Hour, to define the extent to failure resistance.

Also, although the probability concept used in the two Standards is the same, the result may differ as the rigor of calculation is not the same.

In fact, for evaluating  $PFH_d$ , IEC 62061 specifies a procedure based on formulas derived from the system reliability theory. The results may in some cases, e.g. reduced number of components, high-efficiency of self-diagnostic techniques implemented, turn out to be very low, i.e. very good.

To simplify and speed up evaluation of Probability of Dangerous Failure per Hour, ISO 13849-1 uses approximation tables which must necessarily consider worst case scenarios, with consequently higher results, i.e. inferior to, than those calculated using IEC 62061.

Therefore, extra care must be exercised when calculating overall PL of a serial system such as the following:



If the resulting Probability of Dangerous Failure per Hour for the entire system is calculated as the sum of the  $PFH_d$  values of the parts computed by means of IEC 62061 and not using the calculation procedure as per ISO 13849-1, the limitations imposed to the parts by the categories which restrict max. PL attainable to that actually specified by ISO 13849-1 (see Table 5 of the Standard) must be taken into account.

Otherwise, a higher than actual system PL could result.

The following table may be used as a general guideline, noting that the ranges of Probability of Dangerous Failure per Hour should be compared, not the actual values of SIL and PL.

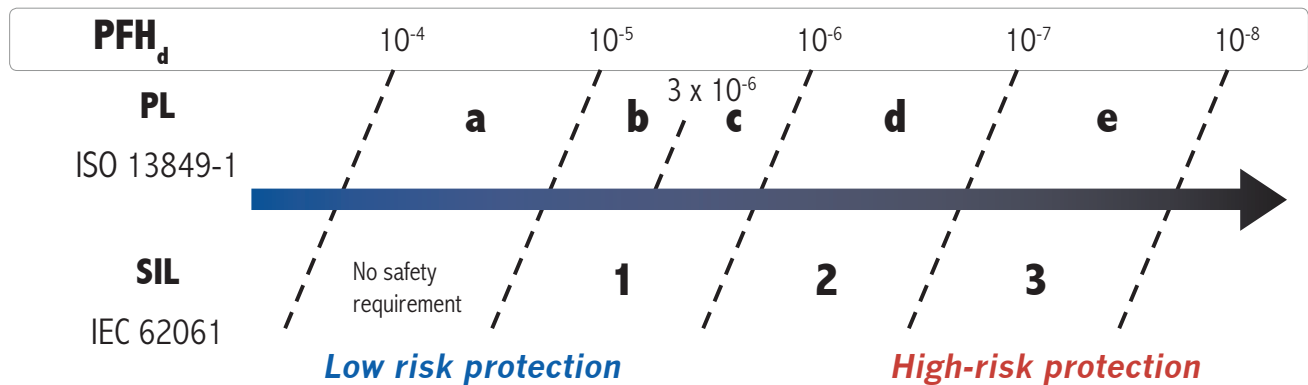

Fig. 9 - Requirements be met to satisfy the functional requirements and safety

# SAFETY IN THE WORKING ENVIRONMENT

## Glossary

Initials	Definition	Standard	Description
$\beta$ (Beta)	Common cause failure factor	IEC 62061	Degree of operational independence of channels of a multi-channel system. Ranging from 0.1 to 0.01 depending on CCF attained.
$\lambda$ (Lambda)	Failure rate	IEC 62061	<p>Random failure frequency. The time-random failure frequency of a component is usually known as Failure Rate, described as number of failures per unit of hour. Its inverse is known as Mean Time Between Failures (MTBF), expressed in hours.</p> <p>Random failures are the result of sudden stress accumulation above maximum design strength of a component. May occur at random intervals and entirely unexpectedly.</p> <p>Frequency of failure over sufficiently long periods is virtually constant. PFH<sub>d</sub> calculation methods given in both Standards refer only to the assessment of random failures.</p> <p>The unit of measure for failure rate is FIT (Failure In Time) equivalent to one failure per billion of operating hours (F=1 means one failure every 10<sup>9</sup> hours).</p>
$\lambda_s$	Safe failure rate	IEC 62061	<p>Failure rate for non-dangerous failures.</p> <p>Non-dangerous failures which have no adverse safety-related effect on control system. The control system continues to ensure protection.</p>
$\lambda_d$	Dangerous failure rate	IEC 62061	<p>Failure rate of failures which may involve dangerous operation.</p> <p>Dangerous failures prevent the control system from continuing to provide protection.</p>
$\lambda_{dd}$	Dangerous detected failure rate	IEC 62061	<p>Failure rate for detectable dangerous failures.</p> <p>Detectable dangerous failures may be detected by automatic self-diagnostic systems.</p>
$\lambda_{du}$	Dangerous undetected failure rate	IEC 62061	<p>Failure rate for undetectable dangerous failures.</p> <p>Undetectable dangerous failures cannot be detected by internal automatic self-diagnostic systems.</p> <p>They determine the value of PFH<sub>d</sub> and, consequently, the value of SIL or PL.</p>
Cat.	Category	ISO 13849-1	<p>The Category is the main parameter to consider to attain a given PL.</p> <p>Describes the SRP/CS performance in relation to its ability to resist failure and resulting performance in failure conditions.</p> <p>Five Categories are envisaged depending on structural positioning of components.</p>
CCF	Common Cause Failure	ISO 13849-1 IEC 62061	<p>Failure resulting from common causes.</p> <p>Failure resulting from one or more events causing simultaneous malfunction of channels of a multi-channel system.</p> <p>Provides a measure of the degree of independence of redundant channel operation.</p> <p>Assessed by assigning marks. Maximum possible score is 100.</p>
DC	Diagnostic Coverage	ISO 13849-1 IEC 62061	<p>Reduced probability of dangerous hardware failure due to automatic self-diagnostic system operation. A measure of system effectiveness in promptly detecting its own possible malfunction.</p> <p>Expressed as 60% to 99%.</p>
MTTF <sub>d</sub>	Mean Time to dangerous Failures	ISO 13849-1	<p>Average operating time, expressed in years, to potentially dangerous random failure (not generic failure). May refer to a single component, or to a single channel, or to the entire safety-related system.</p>

## SAFETY IN THE WORKING ENVIRONMENT

Initials	Definition	Standard	Description
PFH <sub>d</sub>	Probability of dangerous Failure /Hour	IEC 62061	Average probability of dangerous failure per hour. Quantitative representation of risk reduction factor provided by the safety-related control system.
PL	Performance Level	ISO 13849-1	Level of performance. In ISO 13849-1, the extent to which failures are controlled is assessed using the Performance Level concept (PL). Represents SRP/CS ability to perform a safety-related function within predictable operating conditions. There are 5 levels, PLa to PLe. PLe represents the highest level of risk reduction, PLa the lowest level.
PLr	Performance Level required	ISO 13849-1	Level of performance required. Represents the contribution to risk reduction by each safety-related part implemented in SRP/CS. PLr is obtained using the risk curve.
SIL	Safety Integrity Level	IEC 62061	Level of integrity of a safety-related function. Discrete level (one of three) used to describe the ability of a safety-related control system to resist failure as per IEC 62061, where level 3 assures the highest protection and level 1 the lowest.
SILCL	SIL Claim	IEC 62061	Max. SIL attainable by a subsystem in relation to architecture and ability to detect failure.
SRP/CS	Safety Related Parts of Control Systems	ISO 13849-1	Part of machine control system able to maintain or achieve machine safety status in relation to the status of certain safety-related sensors.
SRECS	Safety Related Electrical, electronic and programmable electronic Control System	IEC 62061	Electrical, electronic and programmable electronic control system the failure of which immediately increases the risk factor associated with machine operation.
T1	Proof test interval	IEC 62061	Interval of proof test. The Proof Test is an external manual inspection for detecting component failure and performance decay, undetectable by internal self-diagnostic systems. The unit of measure is time (months or, more usually, years).
T2	Diagnostic test interval	IEC 62061	Test interval of self-diagnostic functions. Time elapsed between one test for the detection of possible internal failure and the next. Tests are carried out in automatic mode by dedicated circuitry which may be internal to the SRECS in question or may belong to other SRECSs. The unit of measure is time (milliseconds to hours).
SFF	Safe Failure Fraction	IEC 62061	Fraction of overall failure rate which does not involve dangerous failure. Represents the percentage of non-dangerous failures relative to total number of failures of the safety-related control system.

# PHOTOELECTRIC SAFETY LIGHT CURTAINS

## CHARACTERISTIC ELEMENTS

Light curtains are electro sensitive devices using one or more light beams, emitted by an Emitter and received by a Receiver, to create an intangible controlled area. Fundamental characteristics are:

### Safety type

- defines the self-monitoring and safety principles contained in the device;
- it must be chosen as a function of the risk level characterising the machine.

When the chosen safety device is a photo-electric barrier (**AOPD** Active Optoelectronic Protective Device), it shall necessary belong to **TYPE 2** or **TYPE 4** as established by the International Standard **IEC 61496 1-2**.

#### **NOTE: why “Type” and not “Category”?**

When talking about light curtains and laser scanners, we normally refer to their “safety type”; while for all other safety devices the term of choice is “safety category”. This distinction is due to the International Standard IEC 61496, in which the term “type” is introduced to determine the safety level of optoelectronics protective equipment. In practice, “type” adds some optical requirements to the requirements which define categories for non-optical safety devices. Therefore, a type 2 light curtain is a light curtain which complies with the requirements for category 2 safety electronics and furthermore whose beams have certain characteristics, among which a given aperture angle, immunity to light interference and so on. The same applies for type 4 light curtains and type 3 laser scanners.

### Protected height

This is the height controlled by the light curtain. If it is positioned horizontally, this value shows the depth of the protected zone.

### Range

This is the maximum working distance that may exist between the emitter and the receiver. When deflection mirrors are used, it is necessary to take into account the attenuation factor introduced by each of them, which it is about 15%.

### Response time

This is the time it takes for the light curtain to transmit the alarm signal from the time the protected zone is interrupted.

## PHOTOELECTRIC SAFETY LIGHT CURTAINS

## Resolution

The resolution of a light curtain is the minimum size of an object that, placed into the controlled area, will obscure the controlled zone and hence stop the hazardous movement of the machine.

- Single beam light barriers: their resolution **R** is the same as the diameter of the lens. **R = D**
- Multibeam light curtains: their resolution **R** is the same as the sum of the lens diameter + the distance between two adjacent lenses. **R = P + D**

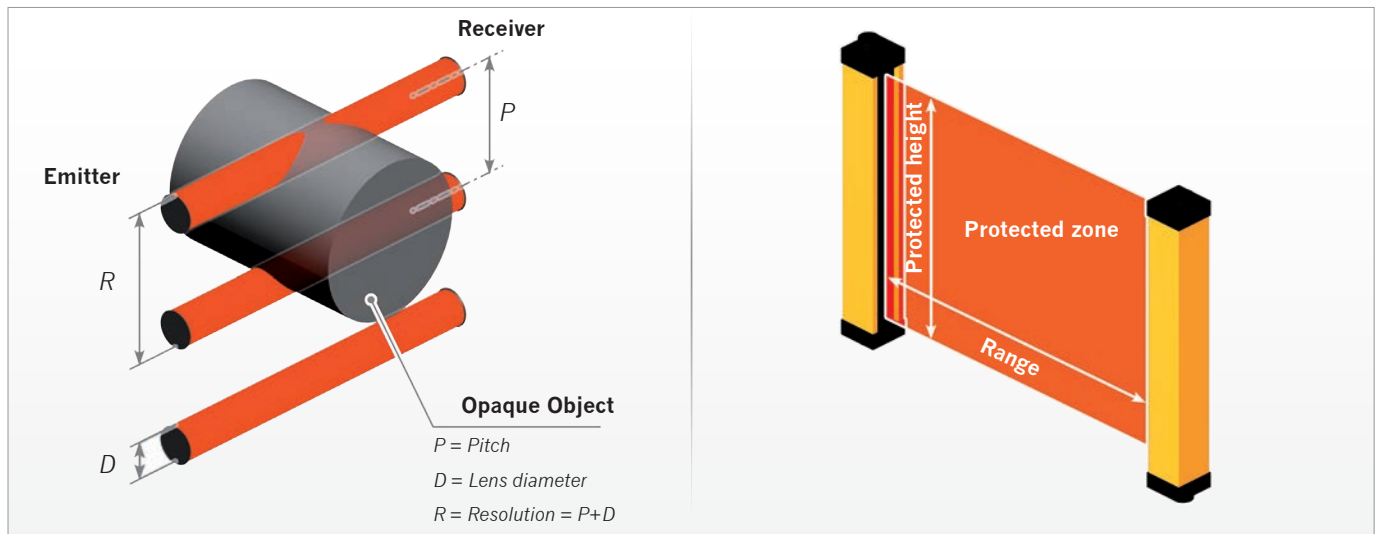

## ADVANTAGES OF LIGHT CURTAINS

- Effective protection in the event of fatigue or distraction of the operator.
- Increase in the productive capacity of the machine as the light curtain does not require the manual handling of physical guards or waiting for them to open.
- Faster machine loading/unloading operations.
- Reduced times of approach to the working areas.
- Elimination of the risk of tampering since any irregular intervention on the light curtain stops the machine.
- Simple and quick installation, with greater flexibility of adjustment on the machine, even in the case of subsequent repositioning.
- Possibility to build up large sized protections, either linear or along a perimeter, on several sides, at greatly reduced costs.
- Facilitated and fast maintenance of the machine, as there is no need to remove physical guards, such as grids, gates, etc.
- Improved appearance and ergonomic effectiveness of the machine.

## CONDITIONS OF USE

**For the photoelectric safety protections to be effective, it is necessary to verify that:**

- It must be possible to electrically interface them to the control unit of the machine.
- It must be possible to stop the hazardous movements of the machine at once. In particular, it is important to know the machine stopping time to place the light curtain at the correct distance.
- The time taken to reach the hazardous point must be greater than the time necessary to stop the hazardous movement.
- The machine must not create secondary dangers due to the projection or fall from above of materials. If this danger exists, additional protections of a mechanical nature have to be provided.
- The minimum size of the object to be detected must be equal to or greater than the chosen light curtain resolution.





## PHOTOELECTRIC SAFETY LIGHT CURTAINS

### SELECTION CRITERIA OF A SAFETY LIGHT CURTAIN

1. **Definition of the zone to be protected.**
2. **Definition of the parts of the body to be detected:**
  - fingers or hands
  - approaching body of a person
  - presence of a person in a hazardous area.
3. **Definition of the safety distance between the light curtain and the hazardous point.**
4. **Definition of the safety category Level/Type to be adopted according to ISO 13849-1, IEC 62061, IEC 61496**

### DEFINITION OF THE ZONE TO BE PROTECTED

- Take into account the configuration of the zone:
  - shape and dimensions: width and height of the access area
  - positions of hazardous parts
  - possible access points.
- The light curtain must be positioned so as to prevent the access to the dangerous area from above, from below, and from the sides without having intercepted the field protected by the light curtain.

It is possible to install one or more deflection mirrors in order to protect areas with access from several sides. This results in a considerable reduction in costs, as this solution eliminates the need of installing many separate light curtains.

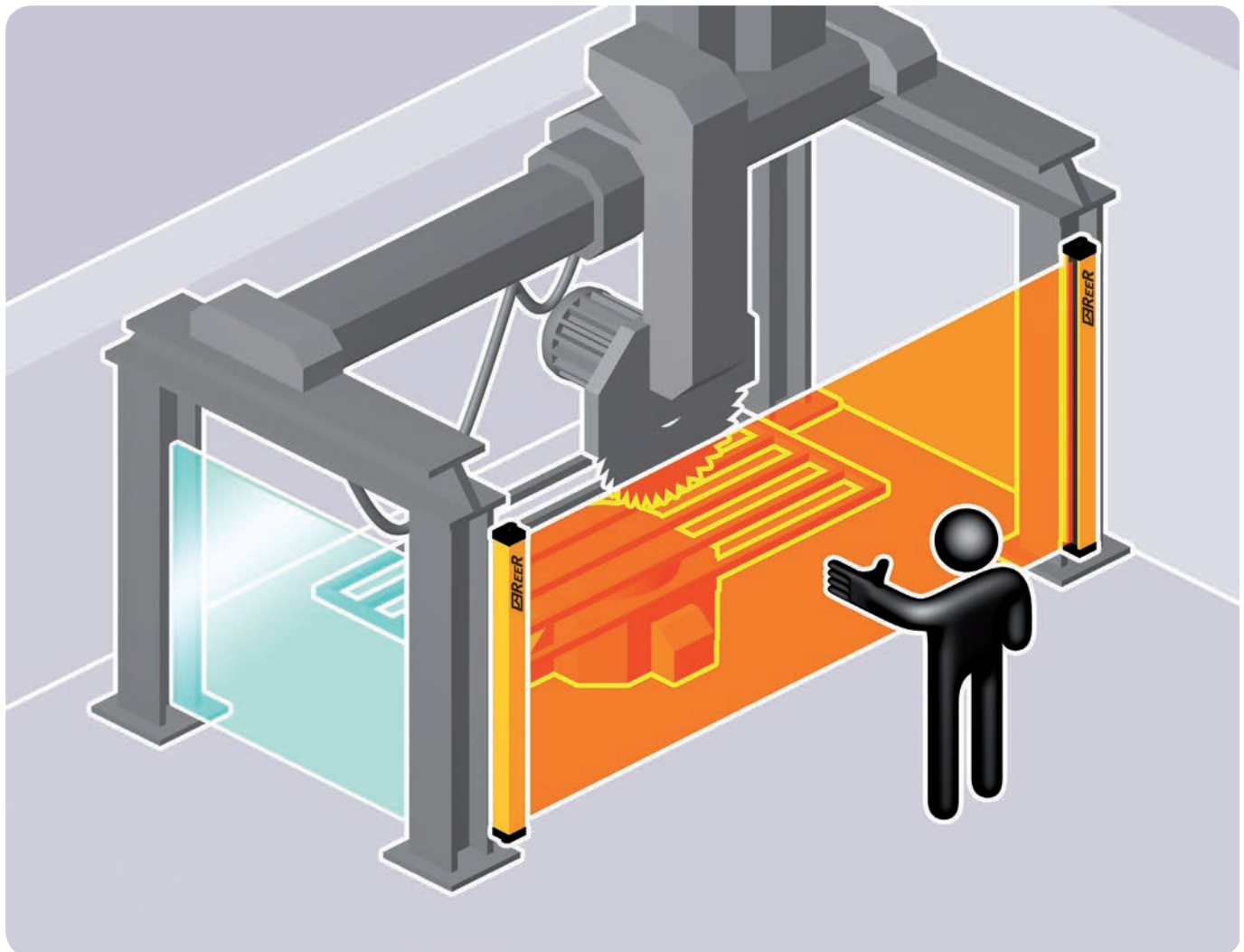

# PHOTOELECTRIC SAFETY LIGHT CURTAINS

## DEFINITION OF TYPE OF DETECTION

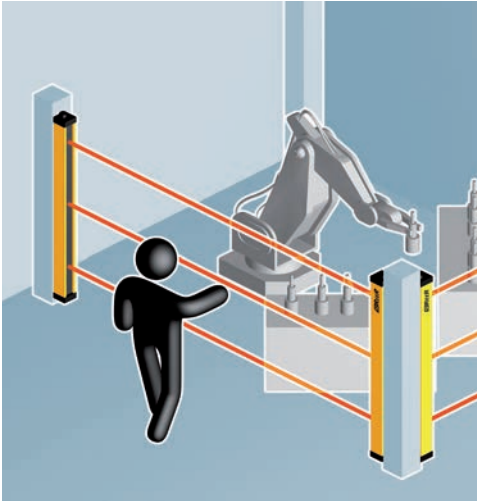
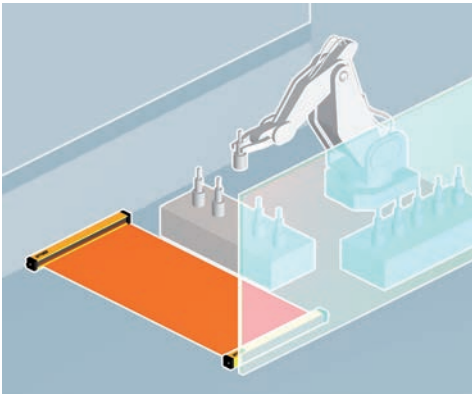
	DETECTION	CHARACTERISTICS	ADVANTAGES
	<b>Finger or hand</b>	<p>Detection necessary when the operator must work close to the danger.</p> <p>Barrier resolution must be between 14 mm and 40 mm.</p>	<p>Possibility to lower the dimensions by reducing at the top the space between the protection and the dangerous zone.</p> <p>Short time for machine charging and discharging.</p> <p>Less operator fatigue, more productivity.</p>
	<b>Body</b> (use as trip device)	<p>Ideal detection for access control and protections of several sides, also for long scanning distances.</p> <p>The barrier must be placed at least at 850 mm from the danger.</p> <p>Barrier normally composed by 2, 3, 4 beams.</p>	<p>Protection costs reduced by the restricted number of beams.</p> <p>Possibility to protect zones with big dimensions by using deflection mirrors.</p> <p>See note below</p>
	<b>Presence in a dangerous zone</b>	<p>Detection realized by positioning the light curtains horizontally to control continuously the presence of an object in a definite zone.</p> <p>The light curtains resolution depends on the height of the detection plane, anyway it cannot be higher than 116 mm.</p>	<p>Possibility to control zones not visible from where the machine's push button controls are located.</p>

**Note:** Accidental start-up of the machine shall not be possible when anyone crosses the sensitive area and stays undetected in the dangerous area. Suitable ways of eliminating this type of risk include the following:

- Use of start / restart-interlock function positioning the command so that the dangerous area is in full view and so that the command cannot be reached by anyone from inside the dangerous area. The Restart command has to be safe in compliance with IEC 61496-1.
- Use of additional presence sensing detectors for the detection of the operator inside dangerous area.
- Use of obstacles preventing the operator from remaining undetected in the space between the sensing zone of the protective device and the dangerous area.

# PHOTOELECTRIC SAFETY LIGHT CURTAINS

## DETERMINATION OF THE SAFETY DISTANCE

The effectiveness of the protection depends greatly on the correct positioning of the light curtain with respect to the danger.

The light curtain must be located at a distance greater than or equal to the minimum safety distance **S**, so that reaching the dangerous point will be possible only when the dangerous action of the machine has been stopped.

The light curtain must be positioned so that:

- It is impossible to reach the dangerous point without going through the zone controlled by the light curtain.
- A person cannot be present in the dangerous zone without his/her presence being detected. To this end, it might be necessary to resort to additional safety devices (i.e.: photoelectric light curtains arranged horizontally).

European Standard EN ISO 13855 provides the elements for the determination of the safety distance.

If the machine in object is governed by a specific C type Standard, it shall be taken into due account.

If the distance **S** determined in this manner is too big, it is necessary:

- a) to reduce the total stopping time of the machine,
- b) to improve the detection capability (resolution) of the light curtain.

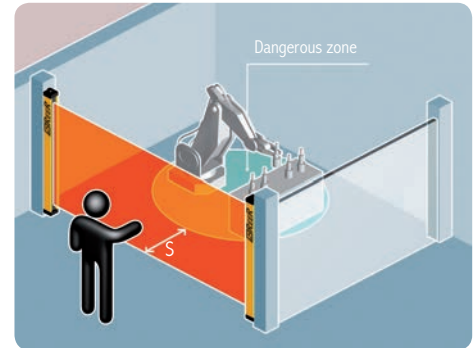

**One-side protection**

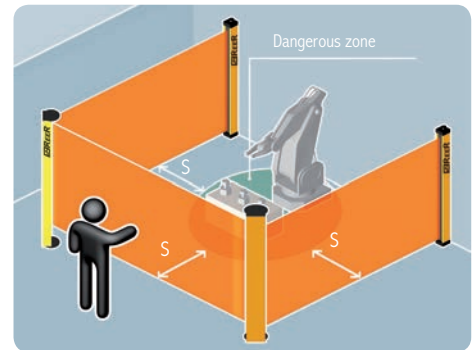

**Three-side protection using deflection mirrors**

## GENERAL FORMULA FOR THE DETERMINATION OF THE MINIMUM SAFETY DISTANCE

$$S = K \times T + C$$

<b>S</b>	minimum safety distance between the protection and hazardous point, expressed in mm.
<b>K</b>	speed of approach of the body or parts of the body, expressed in mm / sec. The K values can be: K = 2000 mm / sec. for safety distance up to 500 mm (forearm movement speed) K = 1600 mm / sec. for safety distance higher than 500 mm (body movement speed).
<b>T</b>	total stopping time of the machine, consisting of: <b>t1</b> reaction time of the protective device in seconds <b>t2</b> reaction time of the machine in seconds, until it stops the hazardous action.
<b>C</b>	additional distance in mm.

# PHOTOELECTRIC SAFETY LIGHT CURTAINS

**C takes into account:**

- Possible intrusion of parts of the body in the sensitive area before they are detected.  
For example:

- $C = 8 \times (d-14)$       If  $d$  (light curtain resolution)  $\leq 40$  mm
- $C = 850$                       If  $d$  (light curtain resolution)  $> 40$  mm  
and for 2 - 3 - 4 beam light curtains
- $C = 1200 - (0,4 \times H)$       for horizontal light curtains  
(See pag. 38)

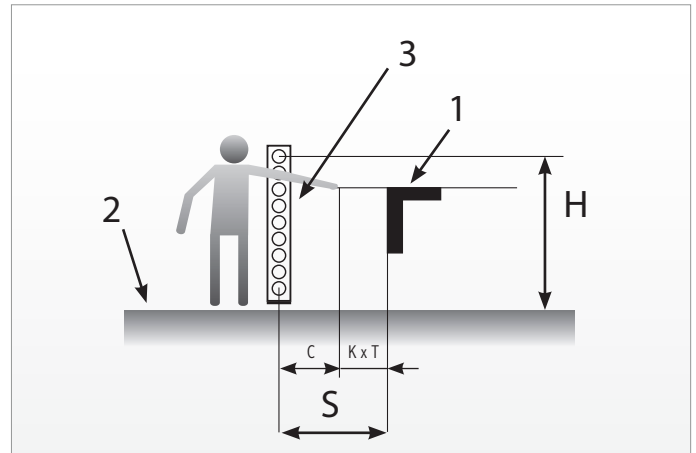

1 = Dangerous area 2 = Reference plane 3 = Light curtain

- The dangerous point can be reached by leaning over the upper edge of the sensitive area of a vertical light curtain.  
In this case C, called " $C_{RO}$ " is obtained from the following Table 2 of EN ISO 13855 / EN 999.

**Note:**

- Interpolation is not allowed.
- If distances a, b or  $C_{RO}$  fall between values listed in the table, use the higher.
- $C_{RO}$  (reaching over) calculated using Table 2 of EN ISO 13855 / EN 999 must be compared to C as conventionally calculated (see paragraph 1).  
Always select the higher value.

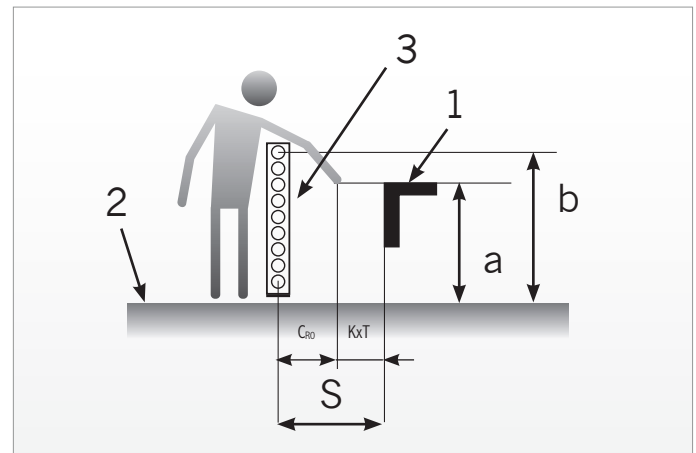

1 = Dangerous area 2 = Reference plane 3 = Light curtain

Height of Hazard zone "a"	Height "b" of upper edge of area protected by photoelectric curtain											
	900	1000	1100	1200	1300	1400	1600	1800	2000	2200	2400	2600
	Alternative distance $C_{RO}$											
2600	0	0	0	0	0	0	0	0	0	0	0	0
2500	400	400	350	300	300	300	300	300	250	150	100	-
2400	550	550	550	500	450	450	400	400	300	250	100	-
2200	800	750	750	700	650	650	600	550	400	250	-	-
2000	950	950	850	850	800	750	700	550	400	-	-	-
1800	1100	1100	950	950	850	800	750	550	-	-	-	-
1600	1150	1150	1100	1000	900	800	750	450	-	-	-	-
1400	1200	1200	1100	1000	900	850	650	-	-	-	-	-
1200	1200	1200	1100	1000	850	800	-	-	-	-	-	-
1000	1200	1150	1050	950	750	700	-	-	-	-	-	-
800	1150	1050	950	800	500	450	-	-	-	-	-	-
600	1050	950	750	550	-	-	-	-	-	-	-	-
400	900	700	-	-	-	-	-	-	-	-	-	-
200	600	-	-	-	-	-	-	-	-	-	-	-
0	-	-	-	-	-	-	-	-	-	-	-	-

(Tabel 2 of ISO 13855/EN 999)

## PHOTOELECTRIC SAFETY LIGHT CURTAINS

3. For combined mechanical and electrosensitive protections (as shown), where it would be possible to lean against the mechanical protection and bypass the light curtain, for the calculation of the parameter **C** should use the Table 1 (for low risk applications) or the Table 2 (for high-risk applications) of ISO 13857:2007 (formerly EN 294) in place of the table on the previous page.

In this catalog the two tables of ISO 13857:2007 (formerly EN 294) - Safety distances to prevent danger zones being reached by upper and lower limbs - are not mentioned.

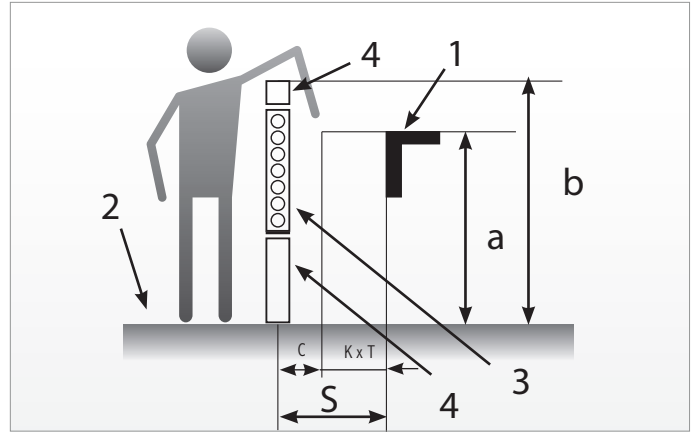

**1** = Dangerous area **2** = Reference plane **3** = Light curtain  
**4** = Mechanical protection

When calculating the safety distance, also consider installation tolerances, accuracy of the measured response time and possible decay of the brake system performance of the machine.

Where brake system decay is possible, use a stopping performance monitor device (SPM).

# PHOTOELECTRIC SAFETY LIGHT CURTAINS

## DIRECTION OF APPROACH PERPENDICULAR TO THE PROTECTED PLANE WITH $\alpha=90^\circ (\pm 5^\circ)$

Light curtains with resolution for the detection of hands and fingers.

**Light curtains resolution (d) ≤ 40 mm**

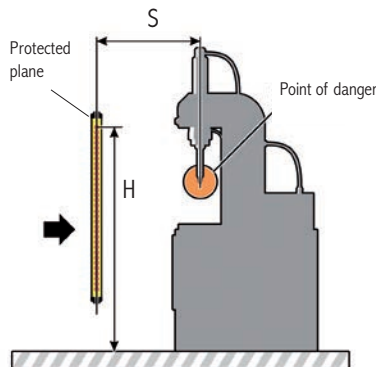

Determination of the minimum safety distance (**S**)

Refer to the general formula for the determination of the minimum safety distance.

$$S = K \times T + C$$

$$S = 2000 \times T + 8 \times (d - 14)$$

if the formula as a result: **S** > 500 you can use K = 1600

$$S = 1600 \times T + 8 \times (d - 14)$$

► For C values see pag. 35

- The distance **S** must not be lower than 100 mm.
- If the distance **S** is greater than 500 mm it is possible to re-calculate the distance using K=1600.
- In these circumstances, the distance must in no case be lower than 500 mm.

Light curtains with a resolution for detection of arms and legs.

**40 mm < Light curtains resolution (d) ≤ 70 mm**

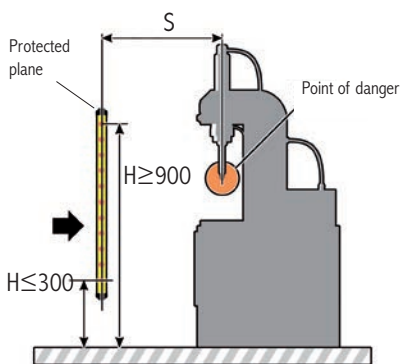

Refer to the general formula for the determination of the minimum safety distance.

$$S = K \times T + C$$

$$S = 1600 \times T + 850$$

► For C values see pag. 35

- The height of the lowest beam must be equal to or lower than 300 mm.
- The height of the upper beam must be equal to or higher than 900 mm.

Light grids for body detection through access control.

**Light curtains resolution (d) > 70 mm**

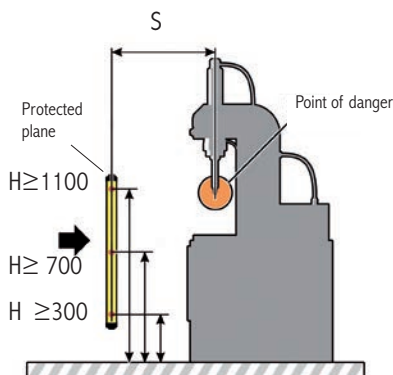

Refer to the general formula for the determination of the minimum safety distance.

$$S = K \times T + C$$

$$S = 1600 \times T + 850$$

► For C values see pag. 35

### Number and height of the beams

N.	Recommended height
2	400 - 900 mm
3	300 - 700 - 1100 mm
4	300 - 600 - 900 - 1200 mm.

# PHOTOELECTRIC SAFETY LIGHT CURTAINS

## DIRECTION OF APPROACH PARALLEL TO THE PROTECTED PLANE WITH $\alpha=0^\circ (\pm 5^\circ)$

Horizontal light curtains for presence control in a dangerous area.

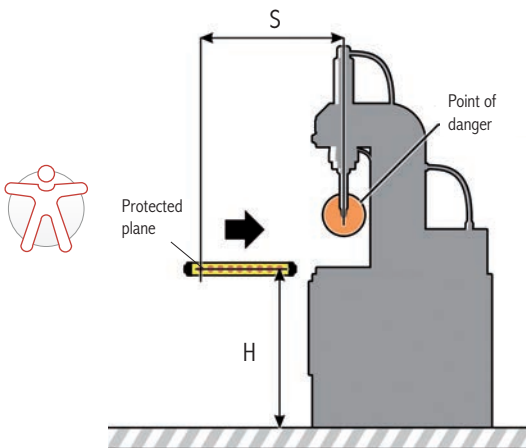

Refer to the general formula for the determination of the minimum safety distance.

$$S = K \times T + C$$

$$S = 1600 \times T + (1200 - 0,4 \times H)$$

► For C values see pag. 35

- $C = 1200 - (0,4 \times H)$  must be equal to or greater than 850 mm.
- The maximum height allowed is:  
 $H_{max} = 1000$  mm.
- The height H depends on the resolution d of the light curtains and is determined through the following formula:  
 $H = 15 \times (d - 50)$ .
- This formula can also be used to determine the maximum resolution that can be used at the different heights  
 $d = H / 15 + 50$
- For example, the maximum resolution limits will be:  
for  $H = 1000$  mm     $d = 116$  mm  
for  $H = 0$  mm     $d = 50$  mm
- If H is greater than 300 mm, at the stage of risk assessment it becomes necessary to take into consideration the possibility of access from beneath the beams.

## DIRECTION OF APPROACH ANGLED TO THE PROTECTED PLANE WITH $5^\circ < \alpha < 85^\circ$

Slanted light curtains to detect hands and arms and for presence control in the dangerous area.

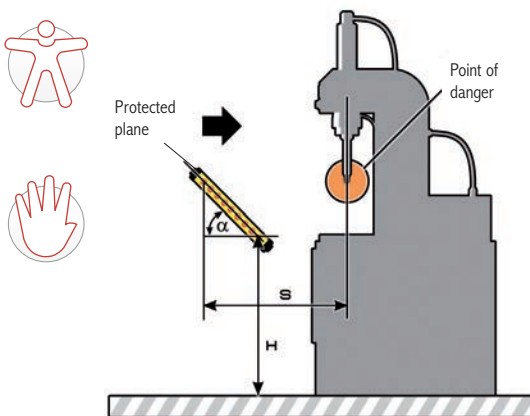

- With angle  $\alpha > 30^\circ$  refer to the case of approach perpendicular to the protected plane. (Previous case)
- With angle  $\alpha < 30^\circ$  refer to the case of approach parallel to the protected plane. (cases of previous page)

With  $\alpha > 30^\circ$ :

- The distance S refers to the beam farthest away from the hazardous point.
- The height of the beam farthest away from the hazardous point must not be greater than 1000 mm.
- For the determination of height H or resolution d apply the following formulas to the lowermost beam:  
 $H = 15 \times (d - 50)$   
 $d = H / 15 + 50$

## PHOTOELECTRIC SAFETY LIGHT CURTAINS

## MUTING FUNCTION

The Muting function is the provisional and automatic cut-out of the light curtain protective function in relation to the machine cycle. Muting can only occur in a safety condition.

Two types of applications are envisaged:

### 1. Enabling personnel access inside dangerous area during the non-dangerous part of machine cycle.

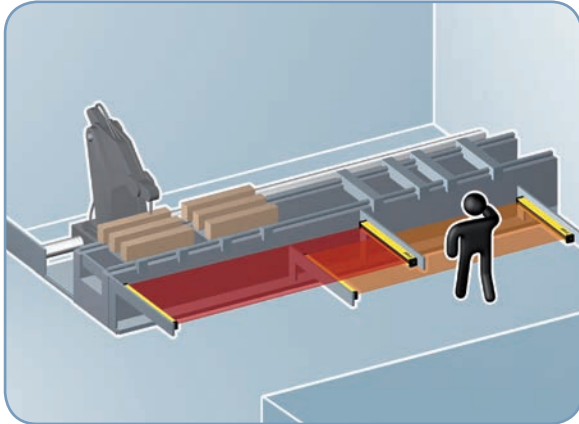

#### Example: Positioning or removal of workpiece

Depending on the position of the tool, which is the most dangerous part, one of the two curtains (the one facing the tool working area) is active whereas the other is in Muting mode to enable the operator to load/unload the workpiece. Muting mode of the light curtains is subsequently reversed when the tool works on the opposite side of the machine.

### 2. Enabling access to material and preventing access to personnel.

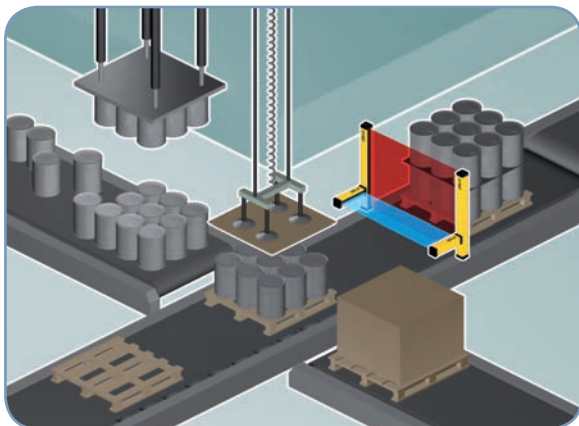

#### Example: Pallet exit from dangerous area

The safety light curtain incorporates Muting sensors able to discriminate between personnel and materials. Only the material is authorized to pass through the monitored area.

The essential requirements regarding the Muting Function are described by the followings Standards:

<b>IEC TS 62046</b>	“Application of the protective equipment to detect the presence of persons”
<b>EN 415-4</b>	“Safety of the Machinery - automatic palletizing systems”
<b>IEC 61496-1</b>	“Electro-Sensitive Protective Equipment”

General Requirements:

- Muting is a temporary suspension of the safety–related function and it must be activated and de-activated automatically.
- The safety integrity level of the circuit implementing the Muting function shall be equal to that of the safety function temporarily suspended, so that the protection performance of the entire system is not adversely affected.
- Muting should be activated and de-activated only by means of two or more separate hardwired signals triggered by a correct time or space sequence.
- It shall not be possible to trigger Muting while the ESPE outputs are in the off state.
- It shall not be possible to initiate Muting by turning the device off and then on again.
- Muting shall be only activated in an appropriate point of the machine cycle, i.e. only when there is no risk for the operator.
- Muting sensors shall be mechanically protected to prevent mismatch in case of impact.



# PHOTOELECTRIC SAFETY LIGHT CURTAINS

## MUTING: PALLETIZERS AND MATERIALS HANDLING SYSTEMS

### Requirements for the monitoring of the openings:

- Monitor the load, not the pallet, otherwise the operator might go into the hazardous zone being dragged by the pallet.
- Muting time must be restricted to the actual time taken by the material to pass through the opening.
- Muting must be time-restricted.
- Sensor mismatch with effect similar to their actuation shall not allow a condition of permanent Muting.
- The configuration and positioning of the Muting sensors shall ensure reliable differentiation between personnel and material.
- The layout of the opening, the positioning of the Muting sensors and the additional side protections shall prevent personnel access to the dangerous area for all the time the Muting function is activated and throughout the time the pallet crosses the opening.

Therefore it is necessary to realise a safety system able to distinguish between:

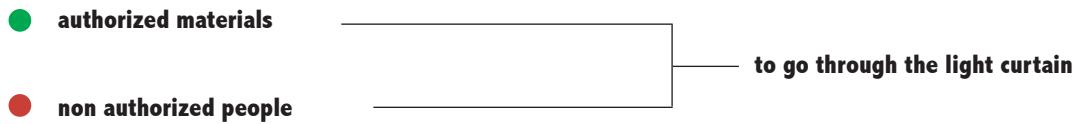

The Muting function can be present on both type 2 and type 4 safety light curtains.

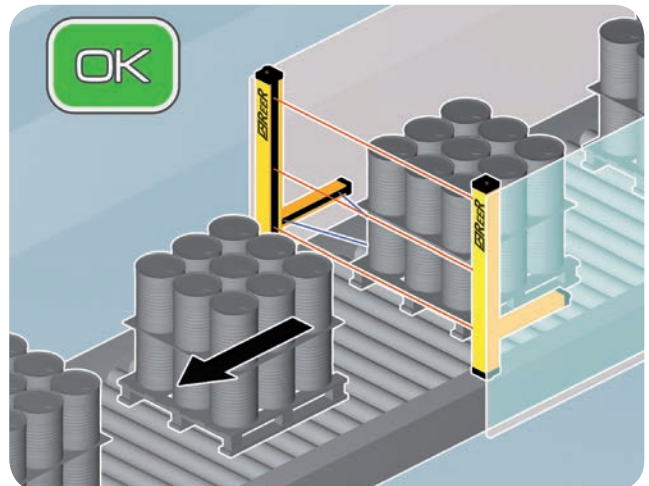
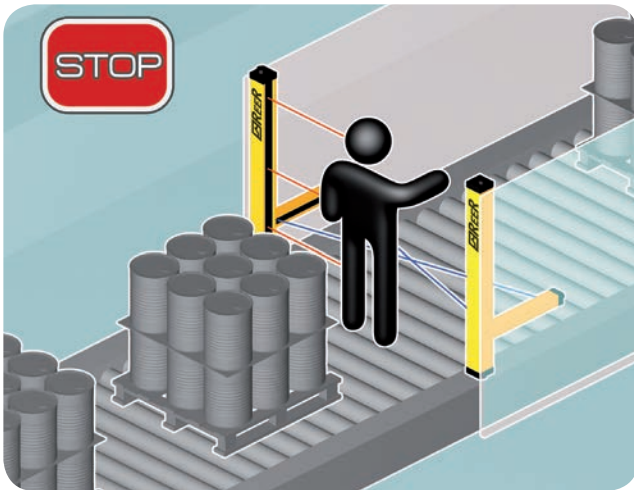

## PHOTOELECTRIC SAFETY LIGHT CURTAINS

## Common solutions for Muting sensor positioning

**Muting with 2 crossed-beam sensors – Configuration type T with timing monitoring and two-way pallet operation:**

- The point of intersection of the two beams shall lie in the segregated dangerous area beyond the light curtain.
- A fail safe timer shall be provided to restrict Muting to the time needed for the material to cross the opening.
- The Muting function shall be activated only if the Muting sensors are contemporaneously intercepted: ( $t_2(S_2) - t_1(S_1) = 4$  seconds max.).
- The two beams shall be continuously interrupted by the pallet throughout the transit through the sensors.
- A matt cylindrical object  $D=500$  mm (simulating the size of a human body) shall not trigger the Muting function.

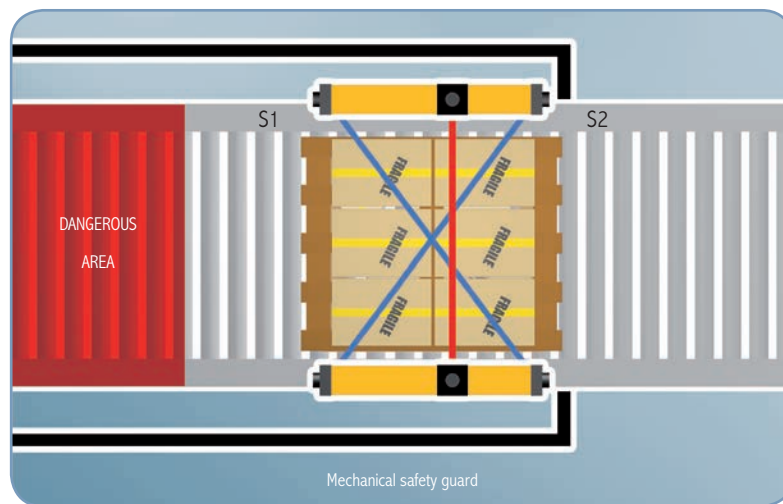

Muting sensor beam intersection shall be positioned the higher up or equal than level of the lower light curtain beam to avoid possible tampering or accidental triggering of Muting.

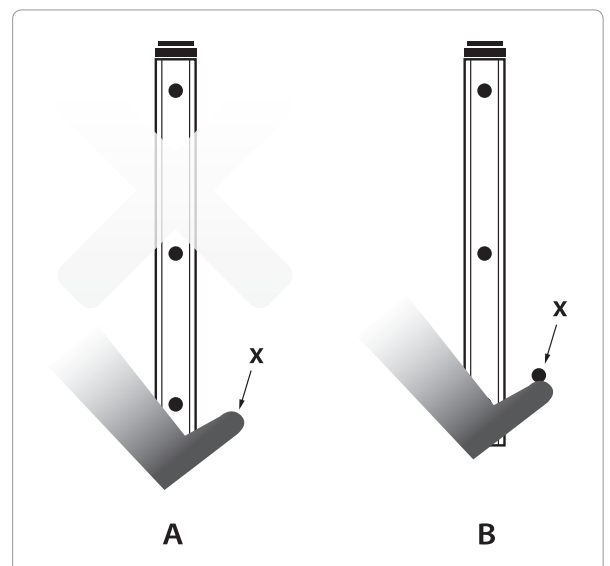
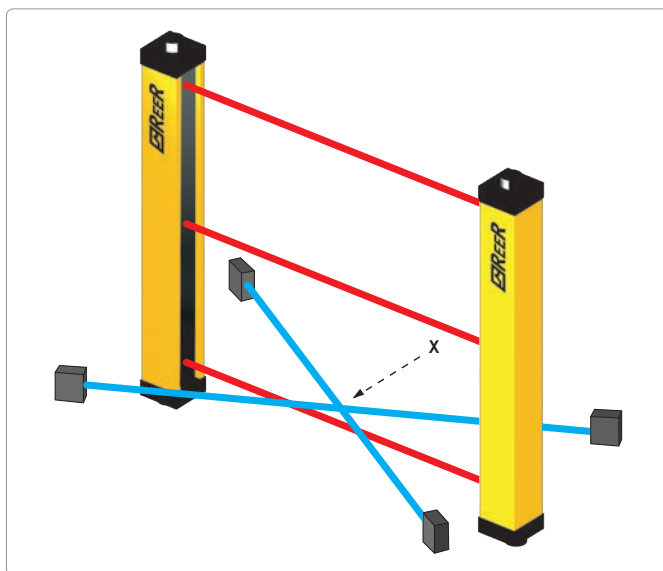

## PHOTOELECTRIC SAFETY LIGHT CURTAINS

### Muting with 4 parallel-beam sensors – Configuration type T with timing and/or sequence monitoring - Two-way pallet operation:

- The 4 Muting sensors shall be all actuated together for a brief moment (sequential actuation and de-activation of the 4 sensors).
- The distance between sensors and the sensing field of the light curtain shall be:
  - **d1 and d3 < 200 mm** to prevent undetected personnel access by preceding or following immediately after the pallet during Muting.
  - **d2 > 250 mm** to prevent personnel limb, garment, etc. from enabling Muting by triggering two sensors simultaneously.

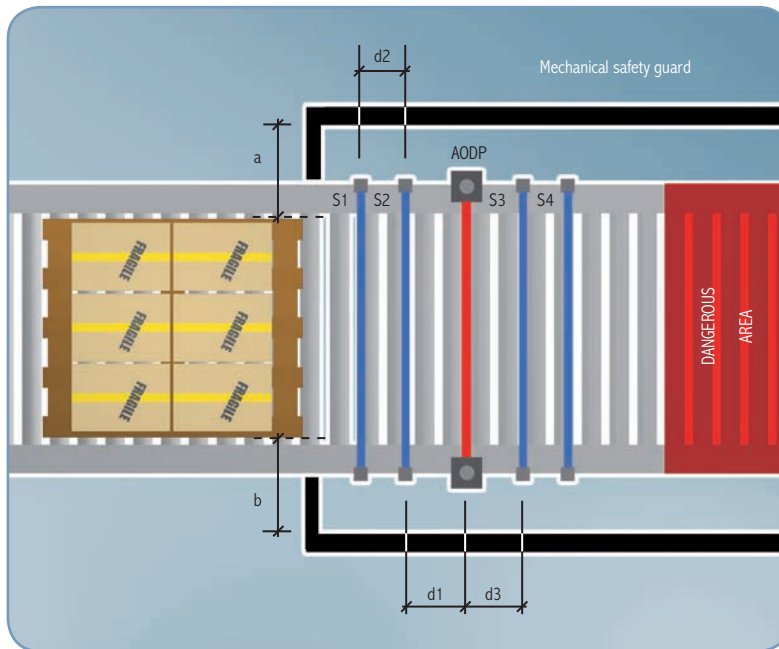

### Muting with 2 crossed-beam or parallel-beam sensors – Configuration type L with timing monitoring and one-way only (exit from dangerous area) pallet operation:

- Muting sensors shall be positioned beyond the light curtain in the dangerous area.
- Muting shall be disabled as soon as the light curtain is cleared and not later than 4 seconds max. from the instant the first of the two Muting sensor is cleared. The timer monitoring the 4 seconds shall be a safety-related item.

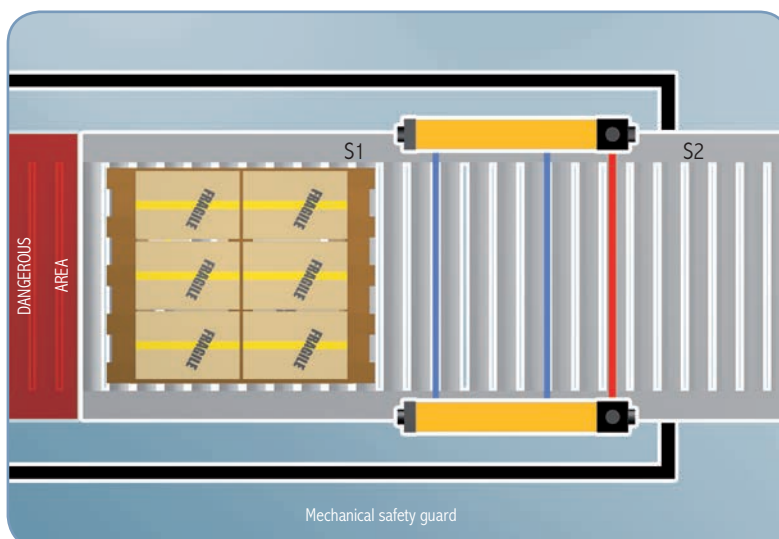

## PHOTOELECTRIC SAFETY LIGHT CURTAINS

## BLANKING FUNCTION

**Blanking** is an auxiliary function of safety light curtains for which the introduction of an opaque object inside parts of the light curtain's protection field is allowed without causing the stoppage of the machine. Blanking is only possible in the presence of determined safety conditions and in accordance with a configurable operating logic.

The blanking function is therefore particularly useful when the light curtain's protection field must be inevitably intercepted by the material being worked or by a fixed or mobile part of the machine.

In practice, it is possible to keep the light curtain's safety outputs in an ON condition, and the machine working, even if a pre-determined number of beams within the protection fields are being intercepted.

**Fixed Blanking** allows a fixed portion of the protection field (i. e. a fixed set of beams) to be occupied, while all the other beams operate normally.

**Floating Blanking** allows the object to move freely inside the light curtain's protection field occupying a given number of beams, at the condition that the occupied beams are adjacent and that their number is not higher than the configured one.

**Floating Blanking with compulsory object presence** makes the light curtain work in a reverse way within the blanked portion of the protection field. That is, the blanked beams must be occupied during blanking and therefore the object has to be inside the protection field for the light curtain to remain in the ON state. In this case too the object can move freely within the protection field if the above conditions are respected.

Requirements for the blanking function can be found in the Technical Specification IEC/TS 62046 describing additional means that may be required to prevent a person from reaching into the hazard through the blanked areas of the detection zone.

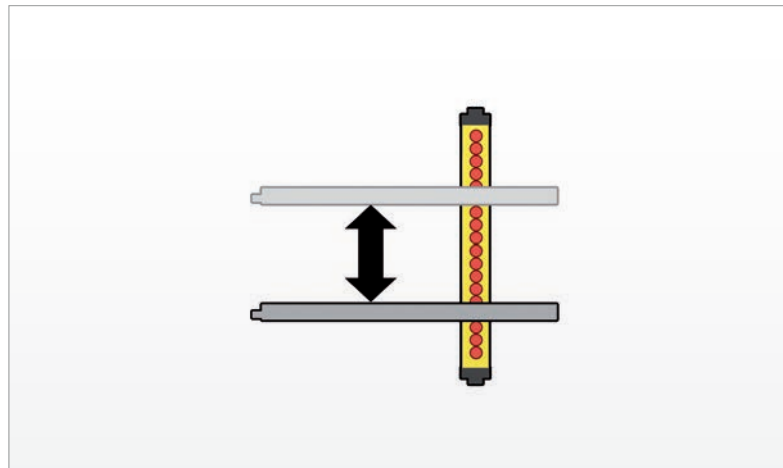
**WARNING!**

The use of the blanking function can be allowed depending on the characteristics of the application to be protected. Based on the risk analysis of your application, check whether the use of the blanking function is allowed for that particular application and with what features.

ReeR SpA does not assume responsibility for the improper use of the blanking function nor for the possible damages deriving from it.

The use of the blanking function may need a recalculation of the safety distance due to the modified detection capability.

## SAFETY LASER SCANNER

### CHARACTERISTIC ELEMENTS

The Safety Laser Scanner is an electro-sensitive device for the protection of operators against the risk of accidents caused by industrial machines and plants with potentially dangerous moving parts and against possible collisions with Automatic Guided Vehicles (AGV).

For **EN 61496-3**, Laser Scanners must be certified in accordance to **type 3** or lower (**AOPDDR** Active Optoelectronics Protective Device responsive to Diffuse Reflection).

For **IEC 61508**, **IEC 62061**, **ISO 13849-1**, they must be certified as **SIL 2 - PLd** or lower.

Using the Safety Laser Sensor, precise programmable **horizontal protected areas** of variable shape can be created (i. e. semi-circular, rectangular or segmented), suitable for all applications with no need of a separate reflective or receiving element.

It is also possible to use the Laser Scanner in a **vertical** position for the access protection to a dangerous area, in that case detection of the edge of the gate is mandatory (**IEC TS 62046**).

Any person or object entering or remaining in the safety zone during survey causes, through the self-monitored static safety outputs of the device, an emergency stop command to the control system of the protected machine. The machine's hazardous movement will thus be interrupted.

If the warning zone is instead occupied, thanks to a non-safety dedicated solid state output, a signal is sent to the machine control system, which can be used to activate a light or a sound signal in order to prevent operators to break into the safety zone and stop the machine. Or, on an AGV application, the warning signal can be used to slow the vehicle down, so that a possible further break of the safety zone will not force it to stop abruptly, thus reducing the mechanical wear of the AGV.

The profiles of the controlled areas, as well as all the other configurable parameters, are programmable through a dedicated user interface software, installed on a laptop or PC and connected with the scanner via a serial interface.

The Laser Scanner is also able to automatically detect the controlled area by means the teach-in function.

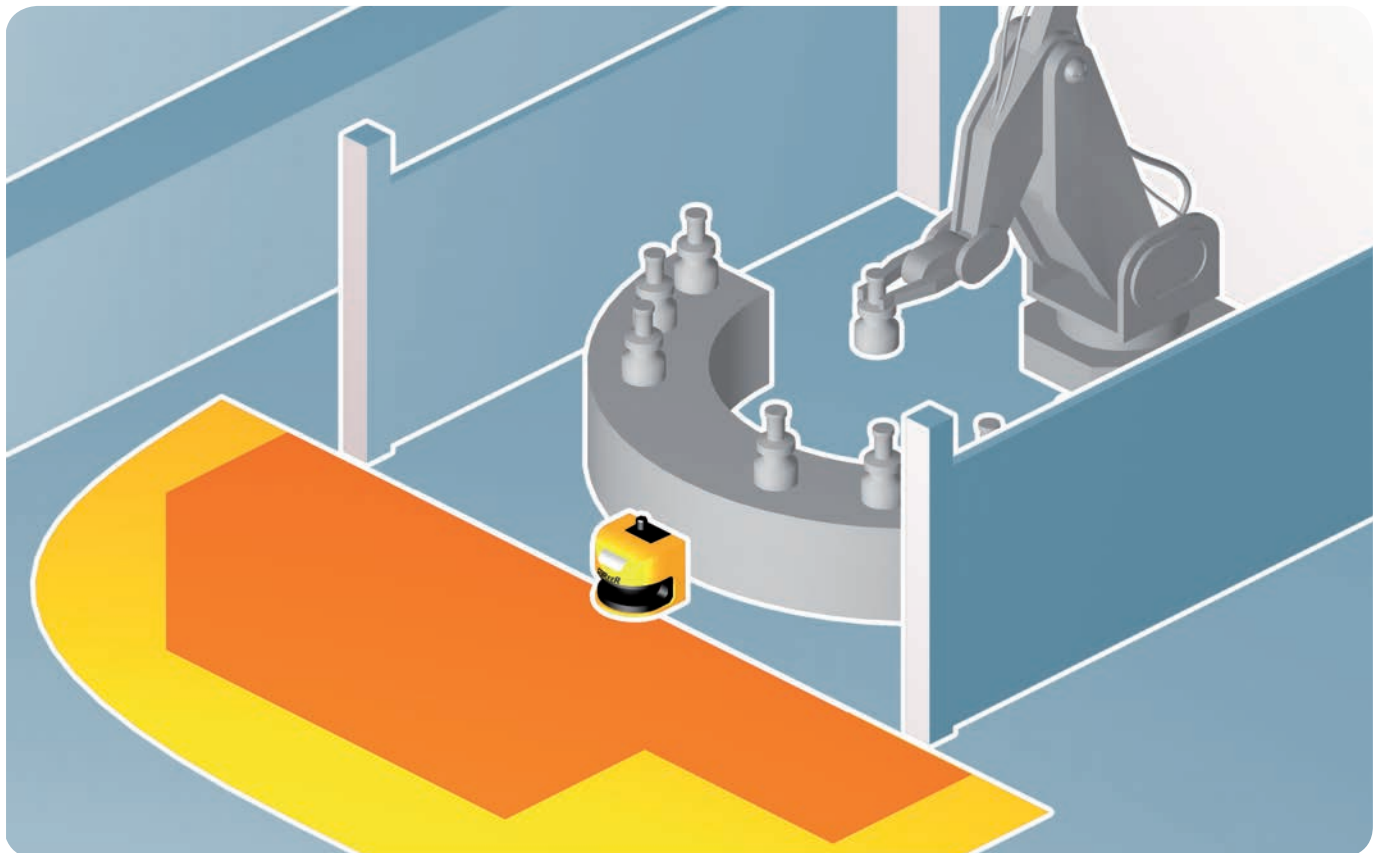

## SAFETY LASER SCANNER

## OPERATING PRINCIPLE OF THE LASER SCANNER PHARO

The Safety Laser Scanner Pharo emits ultra-short infrared laser light pulses. If the emitted beam hits an obstacle inside the controlled zone, then part of the light is reflected back towards the point of emission.

With its state-of-the-art technology, the Laser Scanner is able to measure the time (billionth of second) taken by the light to travel across the space between the sensor and the obstacle and back and to convert it into a distance with a precision of 3 cm.

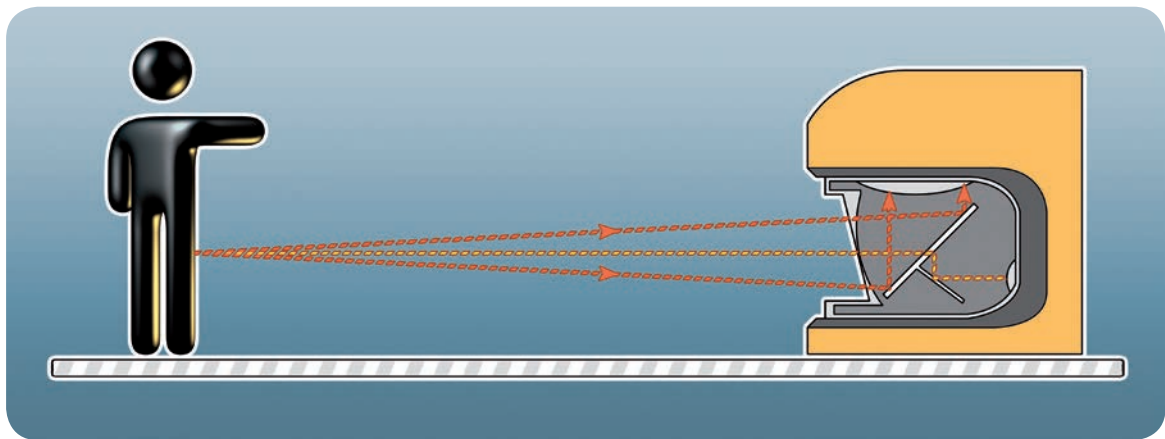

Using a rotating optical system, these measurements are made on a  $190^\circ$  semi-circular area every  $0.25^\circ$  for a total of 760 measurements per scan. The device performs 33 scans per second.

The Safety Laser Scanner Pharo creates a **controlled safety area with a maximum radius of 4 meters and a warning area with a maximum radius of 20 meters**. The safe detection of a person inside the safety zone is assured independently from the reflectivity of its clothes or skin.

The shape of the two controlled areas is fully programmable. Therefore, for each of the 760 measurements per scan, the laser scanner will compare the programmed distance to the measured distance.

If the measured distance is less than the programmed one, this means that an obstacle is inside the safety zone. A stop command will thus be sent to the machine.

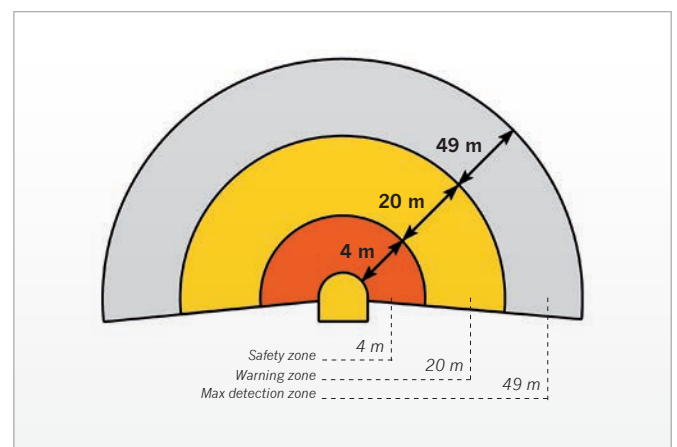
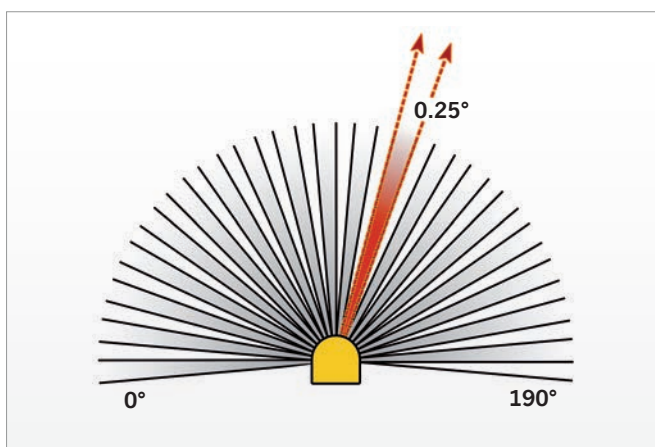

## SAFETY LASER SCANNER

### CONTROLLED AREAS

#### SAFETY ZONE

This is the effective protection zone, in which the laser scanner assures the detection of any obstacle having a minimum reflectivity to infrared light of 1.8%. This means any human body in any possible clothing.

The occupation of this zone causes the switching of the two safety outputs that control the emergency stopping of the machine.

The shape of the zone can be programmed according to the application requirements.

#### WARNING ZONE

This is the zone in which the laser scanner is able to detect the presence of an obstacle approaching the safety zone.

The occupation of this zone causes the switching of the auxiliary output that can be used to activate light or sound signals or in order to slow down the hazardous movement.

This zone is generally larger than the safety zone. In this case also the shape of the zone can be programmed according to the application requirements.

#### ADVANTAGES OF THE LASER SCANNER

- No receiving and reflecting elements.
- Simple programming of differently-shaped controlled areas.
- Monitoring and protection of large areas.
- Horizontal mount for the detection of the body in a dangerous area.
- Vertical mount for the detection of hands and arms or for the detection of the body in access control.
- Use on moving vehicles (AGVs).
- Measurement of object size, shape and position.
- Fast and reliable installation.

## APPLICATIONS

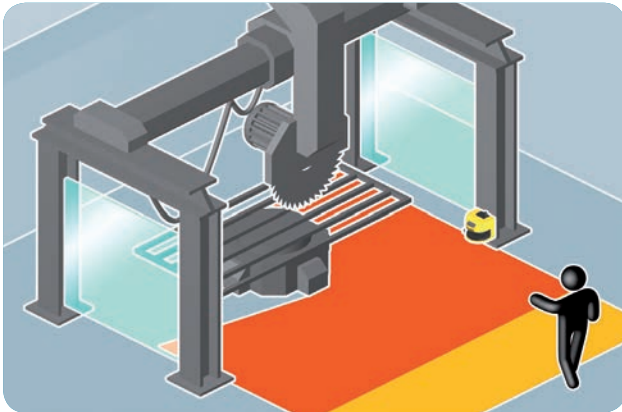
**Area control**

Example of an horizontally mounted protective field permanently monitored by Pharo. In this way a larger area can be monitored through the detection of the lower limbs of the body.

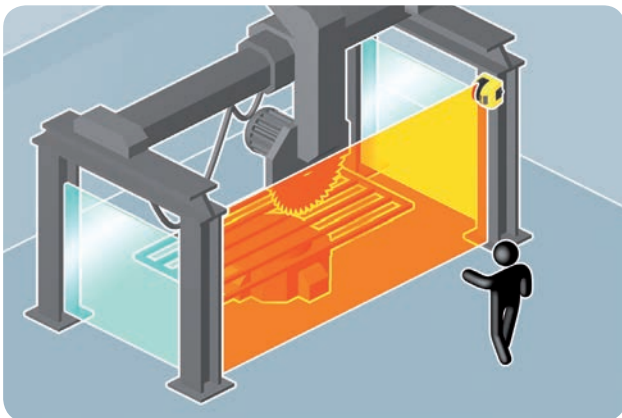
**Access control**

If the controlled plane is installed in a vertical position, even very large accesses can be protected. Hands, arms or the whole body can be detected, depending on the chosen resolution.

**Note:** the contour detection is mandatory for the vertical mount / access control applications.

**Protection of Automatic Guided Vehicles (AGV)**

The vast size of the controlled area allows the AGV to travel at higher speeds with respect to bumper protection.

The warning area permits speed reduction in the presence of obstacles.

The data measured by the sensor can be sent to the vehicle on the serial interface and used as navigation aid.

**Dimensional measurement**

The sensor is first of all a measurement device. Therefore, the measurement data of the surrounding environment, which are always available during operation, can also be used for object profile, position and dimensions measurement in industrial automation.



## INTEGRATION OF THE ESPE

As the ESPE will be integrated in the machine safety-related control system, the choice of its safety level will depend on the result of risk analysis and, consequently, on parameters such as PL, SIL or Category resulting from this analysis.

Product Standards (Type C) usually recommend the most suitable ESPE type for each safety-related function involved. If type C Standards are not available, adopt the recommendations of ISO 13849-1 and IEC 62061.

Also consider that the overall safety integrity of the serial connection: input – control unit – actuators, shall necessarily be equal to or lower than that of the weaker device.

### RULES FOR CORRECT INTERCONNECTION OF PROTECTION DEVICES TO MACHINE CONTROL SYSTEM

The interconnections between safety outputs of ESPE (OSSD) and the machine primary control elements, the positioning and selection of reset push buttons shall not reduce or eliminate the extent of safety integrity assigned to the safety-related machine control system.

Figure 1 shows the most common example, i.e. where the machine control and monitoring system (e.g. the PLC) has no safety-related function. In this case, the safety-related control system monitoring the protective devices connected to it must operate autonomously and must be inserted between the machine control system and the machine primary control elements.

Figure 1

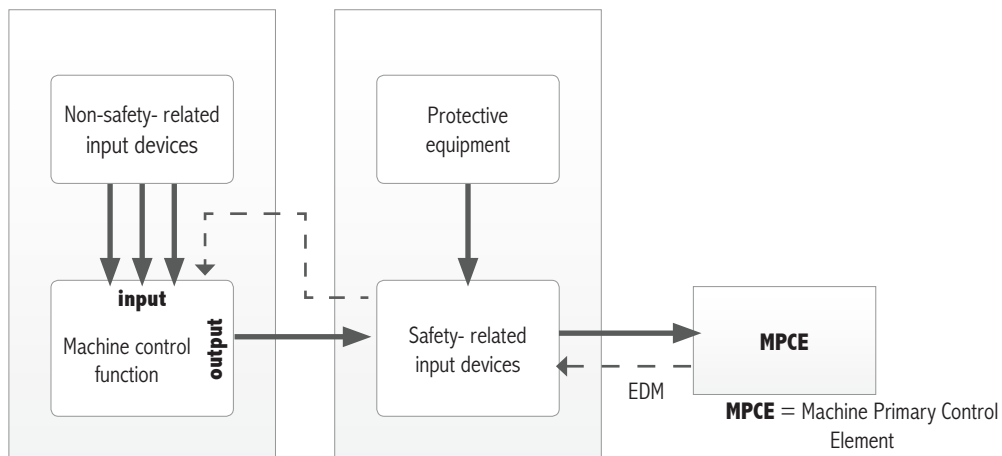

If the machine is equipped with an integrated safety-related control and management system (safety-related PLC), see figure 2, machine operational functions and safety-related functions should be governed through the centralized safety-related system.

Figure 2

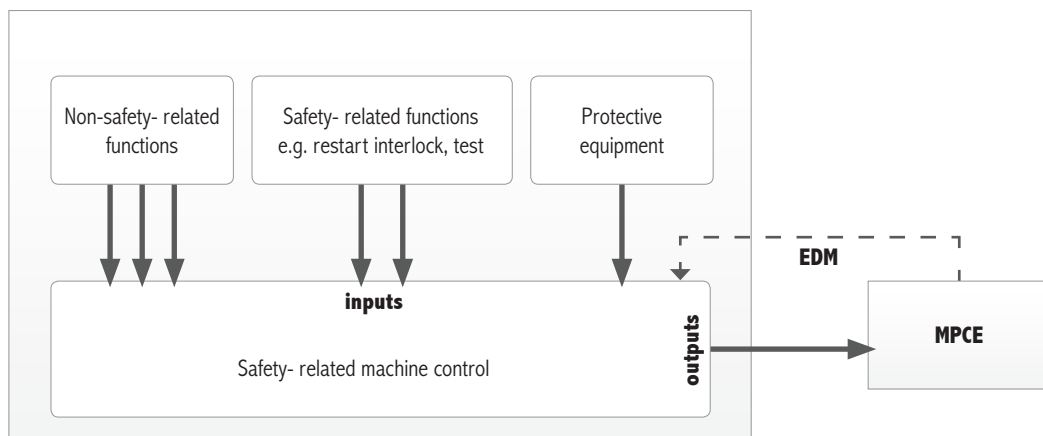

# SAFETY SENSORS



## SAFETY SENSORS

	EOS 4 A	EOS 4 X	ADMIRAL AD	ADMIRAL AX	ADMIRAL AX BK
<b>Sensor</b>	Light curtain	Light curtain	Light curtain	Light curtain	Light curtain
<b>Safety level</b>	Type 4 SIL 3 – PL e	Type 4 SIL 3 – PL e	Type 4 SIL 3 – PL e	Type 4 SIL 3 – PL e	Type 4 SIL 3 – PL e
<b>Resolution (mm)</b>	14	14	14	14	14
<b>Protected heights (mm)</b>	160 ... 1810	160 ... 1810	160 ... 1810	160 ... 1810	160 ... 1810
<b>Max. range m</b>	6	6	5	5	5
<b>Start/Restart, Interlock</b>	-	yes	-	yes	-
<b>EDM</b>	-	yes	-	yes	-
<b>Blanking</b>	-	-	-	-	yes, floating
<b>Master, Slave</b>	-	yes (1 or 2 slave)	-	yes (1 slave)	yes, master

	EOS 4 A	EOS 4 X	ADMIRAL AD	ADMIRAL AX	ADMIRAL AX BK	JANUS M	JANUS J
<b>Sensor</b>	Light curtain	Light curtain	Light curtain	Light curtain	Light curtain	Light curtain	Light curtain
<b>Safety level</b>	Type 4 SIL 3 – PL e	Type 4 SIL 3 – PL e	Type 4 SIL 3 – PL e	Type 4 SIL 3 – PL e	Type 4 SIL 3 – PL e	Type 4 SIL 3 – PL e	Type 4 SIL 3 – PL e
<b>Resolution (mm)</b>	20, 30, 40	20, 30, 40	20, 30, 40	20, 30, 40	20, 40	30, 40	40
<b>Protected heights (mm)</b>	160 ... 1810	160 ... 1810	160 ... 1810	160 ... 1810	160 ... 1810	310 ... 1810	610 ... 1210
<b>Max. range m</b>	12 or 20	12 or 20	18	18	18	16 or 60	16 or 60
<b>Start/Restart, Interlock</b>	-	yes	-	yes	-	yes	yes
<b>EDM</b>	-	yes	-	yes	-	yes	yes
<b>Blanking</b>	-	-	-	-	yes, floating	-	-
<b>Muting</b>	-	-	-	-	-	yes	-
<b>Master, Slave</b>	-	yes (1 or 2 slave)	-	yes (1 slave)	yes master	-	-
<b>Long Range</b>	-	-	-	-	-	yes (up to 60 m)	yes (up to 60 m)

## SELECTION GUIDE

It is advisable to break down the applications of optoelectronic safety devices into four groups.



**Finger detection**



**Detection of the presence of the body in a dangerous area**



**Hand detection**



**Detection of the body in access control**

In the rest of the catalog, for each of the applications listed above, the appropriate solutions realized with the devices in the ReeR range are presented.

Depending on the functions to be performed by the safety system, on the resolution required or on the maximum scanning distance, it is possible to select, among the different families of ReeR's safety protective devices, the right tool for the safeguarding of dangerous machines.

PHARO	EOS 2 A	EOS 2 X	VISION V	VISION VX	VISION VXL	VISION MXL
Laser scanner	Light curtain	Light curtain	Light curtain	Light curtain	Light curtain	Light curtain
Type 3 SIL 2 – PL d	Type 2 SIL 2 – PL d	Type 2 SIL 2 – PL d	Type 2 SIL 2 – PL d	Type 2 SIL 2 – PL d	Type 2 SIL 2 – PL d	Type 2 SIL 2 – PL d
30, 40 selez.	30, 40	30, 40	20, 30, 40	20, 30, 40	30, 40	30, 40
-	160 ... 1810	160 ... 1810	160 ... 1810	160 ... 1810	160 ... 1810*	160 ... 1810*
2,6 (radius)	12	12	16	18	8	8
yes	-	yes	-	yes	yes	yes
yes	-	yes	-	yes	yes	yes
-	-	-	-	-	-	-
-	-	-	-	-	-	yes
-	-	yes (1 or 2 slave)	-	yes (1 slave)	-	-
-	-	-	-	-	-	-

\* VXL and MXL with 30 mm resolution: max. protected height 1210 mm

## SAFETY SENSORS

	EOS 4 A	EOS 4 X	ADMIRAL AD	ADMIRAL AX	ADMIRAL AX BK	JANUS M	JANUS J
<b>Sensor</b>	Light curtain	Light curtain	Light curtain	Light curtain	Light curtain	Light curtain	Light curtain
<b>Safety level</b>	Type 4 SIL 3 – PL e	Type 4 SIL 3 – PL e	Type 4 SIL 3 – PL e	Type 4 SIL 3 – PL e	Type 4 SIL 3 – PL e	Type 4 SIL 3 – PL e	Type 4 SIL 3 – PL e
<b>Resolution (mm)</b>	50, 90	50, 90	50, 90	50, 90	40, 90	40, 90	40
<b>Protected heights (mm)</b>	160 ... 1810	160 ... 1810	310 ... 1810	310 ... 1810	310 ... 1810	310 ... 1810	610 ... 1210
<b>Max. range m</b>	12 or 20	12 or 20	18	18	18	16 or 60	16 or 60
<b>Start/Restart Interlock</b>	-	yes	-	yes	-	yes	yes
<b>EDM</b>	-	yes	-	yes	-	yes	yes
<b>Blanking</b>	-	-	-	-	yes, floating	-	-
<b>Muting</b>	-	-	-	-	-	yes	-
<b>Master, Slave</b>	-	yes (1 or 2 slave)	-	yes (1 slave)	yes (master)	-	-
<b>Long Range</b>	-	-	-	-	-	yes (up to 60 m)	yes (up to 60 m)

	EOS 4 A	EOS 4 X	ADMIRAL AD	ADMIRAL AX	JANUS M	JANUS J	PHARO
<b>Sensor</b>	Light curtain	Light curtain	Light curtain	Light curtain	Light curtain	Light curtain	Laser scanner
<b>Safety level</b>	Type 4 SIL 3 – PL e	Type 4 SIL 3 – PL e	Type 4 SIL 3 – PL e	Type 4 SIL 3 – PL e	Type 4 SIL 3 – PL e	Type 4 SIL 3 – PL e	Type 3 SIL 2 – PL d
<b>Number of beams</b>	2, 3, 4	2, 3, 4	2, 3, 4	2, 3, 4	2, 3, 4	2, 3, 4	-
<b>Resolution (mm)</b>	-	-	-	-	-	-	150
<b>Protected heights (mm)</b>	510 ... 910	510 ... 910	510 ... 910	510 ... 910	510 ... 910	510 ... 910	-
<b>Max. range m</b>	12 or 20	12 or 20	18	18 or 60	16 or 60	16 or 60	4 (radius)
<b>Start/Restart Interlock</b>	-	yes	-	yes	yes	yes	yes
<b>EDM</b>	-	yes	-	yes	yes	yes	yes
<b>Muting</b>	-	-	-	-	yes, I, L and T models	-	-
<b>Master, Slave</b>	-	yes (1 or 2 slave)	-	yes (1 slave)	-	-	-
<b>TRX versions with passive retroreflector elements</b>	-	-	-	-	yes (6 m range)	yes (6 m range)	-
<b>Long Range</b>	-	-	-	yes (up to 60 or 80 m)	yes (up to 60 m)	yes (up to 80 m)	-

## SAFETY SENSORS

PHARO	EOS 2 A	EOS 2 X	VISION V	VISION VX
Laser scanner	Light curtain	Light curtain	Light curtain	Light curtain
Type 3 SIL 2 – PL d	Type 2 SIL 2 – PL d	Type 2 SIL 2 – PL d	Type 2 SIL 2 – PL d	Type 2 SIL 2 – PL d
50, 70 selez.	50, 90	50, 90	50, 90	50, 90
-	160 ... 1810	160 ... 1810	310 ... 1810	310 ... 1810
4 (radius)	12	12	16	18
yes	-	yes	-	yes
yes	-	yes	-	yes
-	-	-	-	-
-	-	-	-	-
-	-	yes (1 or 2 slave)	-	yes (1 slave)
-	-	-	-	-

## GLOSSARY:

**Start/Restart interlock:**

Interlock function (manual restart required) at machine start or restart.

**EDM:**

External Device Monitoring; controls the switching of external contactors via feedback input.

**Master, Slave:**

Two or three light curtains can be connected in cascade; all the outputs are managed by only one of these (Master).

**Blanking:**

The light curtain can be programmed to ignore a single object of defined dimensions that may also be greater than the resolution (see page 41).

**Muting:**

The protective function of the light curtain can be inhibited under certain safety conditions (see page 37).

**I Models:**

Models with connections for external Muting sensors.

**L, T Models:**

Models with built-in Muting sensors in pre-assembled kits for pallet outfeed only (L) or infeed/outfeed (T).

EOS 2 A	EOS 2 X	VISION V	VISION VX	VISION VXL	VISION MXL	ILION	ULISSE
Light curtain	Light curtain	Light curtain	Light curtain	Light curtain	Light curtain	Single beam	Single beam
Type 2 SIL 2 – PL d	Type 2 SIL 2 – PL d	Type 2 SIL 2 – PL d	Type 2 SIL 2 – PL d	Type 2 SIL 2 – PL d	Type 2 SIL 2 – PL d	Type 2 SIL 2 – PL d	Type 2 SIL 2 – PL d
2, 3, 4	2, 3, 4	2, 3, 4	2, 3, 4	2, 3, 4	2, 3, 4	1, 2, 3, 4	1, 2, 3, 4
-	-	-	-	-	-	-	-
510 ... 910	510 ... 910	510 ... 910	510 ... 910	510 ... 910	510 ... 910	-	-
12	12	16	18 or 60	8	8	8	6
-	yes	-	yes	yes	yes	yes a), b)	yes a), b)
-	yes	-	yes	yes	yes	yes a), b)	yes a), b)
-	-	-	-	-	yes	yes b)	yes b)
-	yes (1 or 2 slave)	-	yes (1 slave)	-	-	-	-
-	-	-	-	-	-	-	-
-	-	-	yes (up to 60 m)	-	-	-	a: with AUS X control unit b: with AUS XM control unit

## How to read the safety light curtain codes of the EOS series

**EOS** **2** **60** **4** **X**

**Functions of the safety light curtain:**

- A - Automatic Start/Restart
- X - Built-in control functions - EDM and selectable manual/automatic Start/Restart
- H - High range
- M - Master
- S - Slave
- S2 - Slave 2

**Resolution:**

- |           |           |
|-----------|-----------|
| 1 - 14 mm | 4 - 40 mm |
| 2 - 20 mm | 5 - 50 mm |
| 3 - 30 mm | 9 - 90 mm |

**Protected heights:**

- |             |               |               |
|-------------|---------------|---------------|
| 15 - 160 mm | 75 - 760 mm   | 135 - 1360 mm |
| 25 - 260 mm | 85 - 860 mm   | 145 - 1460 mm |
| 30 - 310 mm | 90 - 910 mm   | 150 - 1510 mm |
| 45 - 460 mm | 105 - 1060 mm | 165 - 1660 mm |
| 55 - 560 mm | 115 - 1160 mm | 180 - 1810 mm |
| 60 - 610 mm | 120 - 1210 mm |               |

**Safety level:**

2 or 4

**Family:**

EOS

**EOS** **4** **2B** **X**

**Functions of the safety light curtain:**

- A - Automatic Start/Restart
- X - Built-in control functions - EDM and selectable manual/automatic Start/Restart
- H - High range
- M - Master
- S - Slave
- S2 - Slave 2

**Number of beams:**

- 2B - 2 beams
- 3B - 3 beams
- 4B - 4 beams

**Safety level:**

2 or 4

**Family:**

EOS

EOS4





# EOS4

**EOS4** is a compact Type 4 light curtain with competitive performance and innovative features.

**Its features include:**

- Minimal cross section: 28 x 30 mm.
- No blind area on one side: the position of first beam ensures that the sensitive area extends to end of the light curtain.
- Minimal blind area on connector side.
- The solution with two L-mounted light curtains, e.g. Master-Slave, maintains 40 mm resolution in corner (models with resolution up to 40 mm).
- Easy connection and installation thanks to the M12 connectors and the use of unshielded cables up to 100 m.
- Integrated safety functions, including self-monitoring of static outputs, control of external contactors (EDM) and automatic/manual selectable Restart.
- Exceptional mechanical and electrical robustness are the result of extensive experience gained hands-on with all kinds of applications.
- Operating temperature range: -10 ... 55 °C.
- Protection rate: IP 65 and IP 67 at the same time  
High resistance to infiltration by dust and liquids in a highly compact light curtain.
- Models Master/Slave for cascade connection of two or three light curtains.
- 2 safety PNP static outputs.

Special versions with IP 69K watertight enclosure (WTF and WTHF), also suitable for Food & Beverage industry, available

► [see page 194.](#)

Special models in conformity with the "ATEX Directive" 94/9/CE - Dust zone 22 - Gas Zone 2 available on request

EOS4 light curtains may be connected to the dedicated safety interfaces series AD SR, or directly to contactors actuated and controlled by the light curtain, or to MOSAIC or to suitable commercial safety modules or safety PLCs.

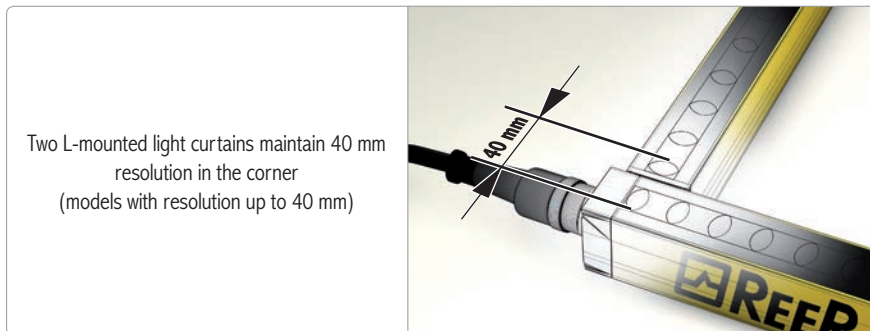

**Safety level: Type 4 – SIL 3 – SILCL 3 – PL e – Cat. 4**

- 2006/42/CE "Machinery Directive"
- 2004/108/CE "Electromagnetic Compatibility (EMC)"
- 2006/95/CE "Low Voltage Directive (LVD)"
- IEC/EN 61496-1 Ed. 2.1, IEC/TS 61496-2 Ed. 2 "Safety of machinery - Electro-sensitive protective equipment- General requirements and tests"
- EN ISO 13849-1 "Safety of machinery – Safety-related parts of control systems – Part 1: General principles for design"
- IEC/EN 62061 "Safety of machinery – Functional safety of safety-related electrical, electronic and programmable electronic control systems"
- IEC 61508 "Functional safety of electrical/electronic/programmable electronic safety-related systems"
- IEC/TS 62046 Ed. 2 "Safety of machinery – Application of protective equipment to detect the presence of persons"
- UL (C+US) mark for USA and Canada
- ANSI / UL 1998 "Safety Software in Programmable Components".



### THE EOS4 RANGE

EOS4 A	EOS4 AH	EOS4 X	EOS4 XH	EOS4 XS - XM - XS2
Max range 12 m (6 m for 14 mm resolution)	Max range 20 m	Max range 12 m (6 m for 14 mm resolution)	Max range 20 m	Max range 12 m (6 m for 14 mm resolution)
Automatic Start/Restart		Integrated, selectable manual or automatic Start/Restart		Master and Slave models for series connection of 2 or 3 light curtains regardless of height or resolution
The ideal light curtain for straightforward interfacing with safety modules (i.e. ADSR1) or safety PLCs (i.e. MOSAIC)		An effective light curtain for directly controlling and monitoring machine circuits with no need of external safety modules		Master and Slave models permit series connection of up to 3 light curtains and combined detection of hand and presence of a person or of more sides of the machine
External relay monitoring (EDM) through external AD SR1, MOSAIC or safety PLC interface		Feedback input for external relay monitoring (EDM)		
Electrical connections: M12 5-pole connectors		Electrical connections: M12 5-pole connector for emitter M12 8-pole for receiver		
Protected height range 160 to 1810 mm				
Types of detection: Resolution 14 mm for finger detection Resolution 20, 30, 40 mm for hand detection Resolution 50, 90 mm for detection of the body in a dangerous area 2, 3, 4 beams for detection of the body in access control				
2 safety static outputs PNP with auto-test protected against short circuits and overloads				

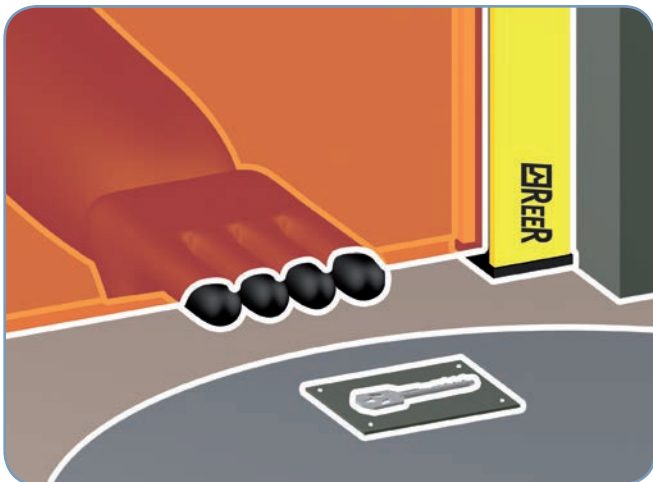

The protected area extends until the light curtain end maintaining the resolution



The resolution is maintained (up to 40 mm) in the junction between the 2 protected areas

# EOS4 A / AH

## WITH AUTOMATIC START/RESTART

### MAIN FEATURES

- Automatic Start/Restart.
- Max. range: up to 6 m for 14 mm resolution; up to 20 m for other models.
- Two safety PNP static outputs, auto-controlled.
- All connections and configurations through M12 5-pole connectors.
- Unshielded cables up to 100 meter long.
- Start/Restart interlock and EDM through external AD SR1 interface.
- Muting function through external AD SRM interface.

### TECHNICAL FEATURES

<b>Safety level</b>	Type 4 according to IEC/TS 61496-2 SIL 3 – SILCL 3 according to IEC 61508 - IEC 62061 PL e – Cat. 4 according to ISO 13849-1
<b>Protected heights (mm)</b>	160 ... 1810
<b>Resolutions (mm)</b>	14, 20, 30, 40, 50, 90
<b>Numbers of beams for body detection in access control</b>	2, 3, 4
<b>Max. range (m)</b>	selectable 3 or 6 for 14 mm resolution; selectable 4 or 12 for standard models; selectable 10 or 20 for H models with: 20, 30, 40, 50, 90 mm resolution and 2, 3, 4 beams:
<b>Response time (ms)</b>	2,5 ... 20
<b>Safety outputs</b>	2 PNP - 400 mA at 24 VDC with short-circuit, overload, polarity reversal protection
<b>Signalling</b>	LEDs for light curtain's status and diagnostic
<b>Start/Restart</b>	automatic
<b>Power supply (VDC)</b>	24 ± 20%
<b>Electrical connections</b>	M12 5-pole
<b>Max. cable length (m)</b>	100
<b>Operating temperature (°C)</b>	-10 ... 55
<b>Protection rating</b>	IP 65 and IP 67
<b>Fastening modes</b>	back slot or to the top and lower end by rotating brackets SFB E180 (optional)
<b>Cross section (mm)</b>	28 x 30

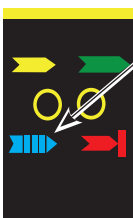

On the receivers of 14 mm resolution and H models a blue LED turns ON when the received beam signal intensity is weak.

During the alignment operations, checking the presence of the blue led weak signal is helpful. Upon completion of alignment and during normal operation, this LED must be off.

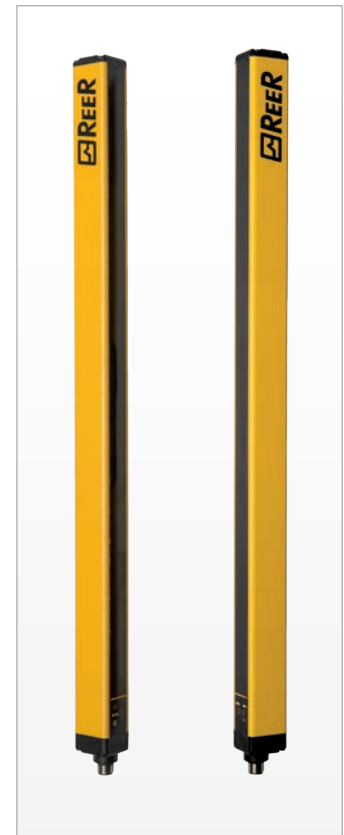

Emitter - 5 poles

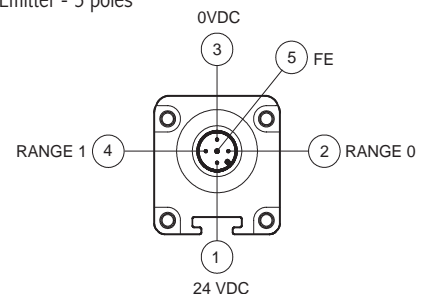

Receiver - 5 poles

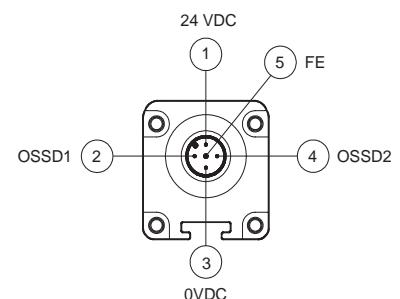

Safety level:

# TYPE 4

SIL 3 – SILCL 3  
PL e – Cat. 4



# TYPE 4 SAFETY LIGHT CURTAIN

## EOS4 A / AH WITH AUTOMATIC START/RESTART

### A Models with 14 mm resolution - Max. range: selectable 3 or 6 m



Resolution 14 mm	EOS4 151 A	EOS4 301 A	EOS4 451 A	EOS4 601 A	EOS4 751 A	EOS4 901 A	EOS4 1051 A	EOS4 1201 A	EOS4 1351 A	EOS4 1501 A	EOS4 1651 A	EOS4 1801 A
Ordering codes	1310000	1310001	1310002	1310003	1310004	1310005	1310006	1310007	1310008	1310009	1310070	1310071
Protected height (mm)	160	310	460	610	760	910	1060	1210	1360	1510	1660	1810
Num. of beams	15	30	45	60	75	90	105	120	135	150	165	180
Overall height (mm)	213	363	513	663	813	963	1113	1263	1413	1563	1713	1863

### A Models - Max. range: selectable 4 or 12 m

### AH Models - Max. range: selectable 10 or 20 m



Resolution 20 mm	EOS4 152AH	EOS4 302AH	EOS4 452AH	EOS4 602AH	EOS4 752AH	EOS4 902AH	EOS4 1052AH	EOS4 1202AH	EOS4 1352AH	EOS4 1502AH	EOS4 1652AH	EOS4 1802AH
Ordering codes	1310150	1310151	1310152	1310153	1310154	1310155	1310156	1310157	1310158	1310159	1310180	1310181
Protected height (mm)	160	310	460	610	760	910	1060	1210	1360	1510	1660	1810
Num. of beams	15	30	45	60	75	90	105	120	135	150	165	180
Overall height (mm)	213	363	513	663	813	963	1113	1263	1413	1563	1713	1863



Resolution 30 mm	EOS4 153 A	EOS4 253 A	EOS4 303 A	EOS4 453 A	EOS4 603 A	EOS4 753 A	EOS4 903 A	EOS4 1053 A	EOS4 1203 A	EOS4 1353 A	EOS4 1503 A	EOS4 1653 A	EOS4 1803 A
Ordering codes	1310200	1311205	1310201	1310202	1310203	1310204	1310205	1310206	1310207	1310208	1310209	1310270	1310271
Resolution 30 mm	EOS4 153AH	-	EOS4 303AH	EOS4 453AH	EOS4 603AH	EOS4 753AH	EOS4 903AH	EOS4 1053AH	EOS4 1203AH	EOS4 1353AH	EOS4 1503AH	EOS4 1653AH	EOS4 1803AH
Ordering codes	1310250	-	1310251	1310252	1310253	1310254	1310255	1310256	1310257	1310258	1310259	1310280	1310281
Protected height (mm)	160	260	310	460	610	760	910	1060	1210	1360	1510	1660	1810
Num. of beams	8	13	16	23	31	38	46	53	61	68	76	83	91
Overall height (mm)	213	313	363	513	663	813	963	1113	1263	1413	1563	1713	1863



Resolution 40 mm	EOS4 154 A	EOS4 254 A	EOS4 304 A	EOS4 454 A	EOS4 604 A	EOS4 754 A	EOS4 904 A	EOS4 1054 A	EOS4 1204 A	EOS4 1354 A	EOS4 1504 A	EOS4 1654 A	EOS4 1804 A
Ordering codes	1310300	1311202	1310301	1310302	1310303	1310304	1310305	1310306	1310307	1310308	1310309	1310370	1310371
Resolution 40 mm	EOS4 154AH	-	EOS 304AH	EOS4 454AH	EOS4 604AH	EOS4 754AH	EOS4 904AH	EOS4 1054AH	EOS4 1204AH	EOS4 1354AH	EOS4 1504AH	EOS4 1654AH	EOS4 1804AH
Ordering codes	1310350	-	1310351	1310352	1310353	1310354	1310355	1310356	1310357	1310358	1310359	1310380	1310381
Protected height (mm)	160	260	310	460	610	760	910	1060	1210	1360	1510	1660	1810
Num. of beams	6	9	11	16	21	26	31	36	41	46	51	56	61
Overall height (mm)	213	313	363	513	663	813	963	1113	1263	1413	1563	1713	1863

## EOS4 A / AH

WITH AUTOMATIC START/RESTART

**A Models - Max. range: selectable 4 or 12 m**

**AH Models - Max. range: selectable 10 or 20 m**



Resolution 50 mm	EOS4 155 A	EOS4 305 A	EOS4 455 A	EOS4 605 A	EOS4 755 A	EOS4 905 A	EOS4 1055 A	EOS4 1205 A	EOS4 1355 A	EOS4 1505 A	EOS4 1655 A	EOS4 1805 A
Ordering codes	<b>1310400</b>	<b>1310401</b>	<b>1310402</b>	<b>1310403</b>	<b>1310404</b>	<b>1310405</b>	<b>1310406</b>	<b>1310407</b>	<b>1310408</b>	<b>1310409</b>	<b>1310470</b>	<b>1310471</b>
Resolution 50 mm	EOS4 155AH	EOS4 305AH	EOS4 455AH	EOS4 605AH	EOS4 755AH	EOS4 905AH	EOS4 1055AH	EOS4 1205AH	EOS4 1355AH	EOS4 1505AH	EOS4 1655AH	EOS4 1805AH
Ordering codes	<b>1310450</b>	<b>1310451</b>	<b>1310452</b>	<b>1310453</b>	<b>1310454</b>	<b>1310455</b>	<b>1310456</b>	<b>1310457</b>	<b>1310458</b>	<b>1310459</b>	<b>1310480</b>	<b>1310481</b>
Protected height (mm)	160	310	460	610	760	910	1060	1210	1360	1510	1660	1810
Num. of beams	4	8	12	16	20	24	28	32	36	40	44	48
Overall height (mm)	213	363	513	663	813	963	1113	1263	1413	1563	1713	1863



Resolution 90 mm	EOS4 309 A	EOS4 459 A	EOS4 609 A	EOS4 759 A	EOS4 909 A	EOS4 1059 A	EOS4 1209 A	EOS4 1359 A	EOS4 1509 A	EOS4 1659 A	EOS4 1809 A
Ordering codes	<b>1310501</b>	<b>1310502</b>	<b>1310503</b>	<b>1310504</b>	<b>1310505</b>	<b>1310506</b>	<b>1310507</b>	<b>1310508</b>	<b>1310509</b>	<b>1310570</b>	<b>1310571</b>
Resolution 90 mm	EOS4 309AH	EOS4 459AH	EOS4 609AH	EOS4 759AH	EOS4 909AH	EOS4 1059AH	EOS4 1209AH	EOS4 1359AH	EOS4 1509AH	EOS4 1659AH	EOS4 1809AH
Ordering codes	<b>1310551</b>	<b>1310552</b>	<b>1310553</b>	<b>1310554</b>	<b>1310555</b>	<b>1310556</b>	<b>1310557</b>	<b>1310558</b>	<b>1310559</b>	<b>1310580</b>	<b>1310581</b>
Protected height (mm)	310	460	610	760	910	1060	1210	1360	1510	1660	1810
Num. of beams	4	6	8	10	12	14	16	18	20	22	24
Overall height (mm)	363	513	663	813	963	1113	1263	1413	1563	1713	1863



2, 3, 4 beams	EOS4 2B A	EOS4 3B A	EOS4 4B A
Ordering codes	<b>1310600</b>	<b>1310601</b>	<b>1310602</b>
2, 3, 4 beams	EOS4 2B AH	EOS4 3B AH	EOS4 4B AH
Ordering codes	<b>1310650</b>	<b>1310651</b>	<b>1310652</b>
Num. of beams	2	3	4
Beams spacing (mm)	500	400	300
Protected height (mm)	510	810	910
Overall height (mm)	653	953	1053

► "ACCESSORIES" on page 69

# TYPE 4 SAFETY LIGHT CURTAIN

## EOS4 X / XH WITH BUILT-IN CONTROL FUNCTIONS

### MAIN FEATURES

Built-in, selectable manual/automatic Start/Restart.  
 Max. range: up to 6 m for 14 mm resolution; up to 20 m for other models.  
 Feedback input for external relays monitoring (EDM).  
 Two safety PNP static outputs, auto-controlled.  
 All connections and setting adjustments through M12 5-pole and 8-pole connectors.  
 Unshielded cables up to 100 meter long.  
 Master and Slave models for series connection of up to 3 light curtains.  
 Max. length of connections toward Slaves: 50 meters, through standard unshielded cables.

### TECHNICAL FEATURES

<b>Safety level</b>	Type 4 according to IEC/TS 61496-2 SIL 3 – SILCL 3 according to IEC 61508 - IEC 62061 PL e – Cat. 4 according to ISO 13849-1
<b>Protected heights (mm)</b>	160 ... 1810
<b>Resolutions (mm)</b>	14, 20, 30, 40, 50, 90
<b>Numbers of beams for body detection in access control</b>	2, 3, 4
<b>Max. range (m)</b>	selectable 3 or 6 for 14 mm resolution; selectable 4 or 12 for standard models; selectable 10 or 20 for H models with: 20, 30, 40, 50, 90 mm resolution and 2, 3, 4 beams:
<b>Response time (ms)</b>	2,5 ... 20
<b>Safety outputs</b>	2 PNP - 400 mA at 24 VDC with short-circuit, overload, polarity reversal protection
<b>Signalling</b>	LEDs for light curtain's status and diagnostic
<b>Start/Restart</b>	selectable automatic or manual
<b>External Device Monitoring</b>	external device monitoring feedback input with selectable enabling
<b>Power Supply (VDC)</b>	24 ± 20%
<b>Electrical connections for EOS4 X and EOS4 X Master</b>	M12 5-pole for emitter M12 8-pole for receiver
<b>Electrical connections between Master and Slave</b>	M12 - 5-pole for emitter and receiver
<b>Max. cable length (m)</b>	100 (50 between Master and Slave)
<b>Operating temperature (°C)</b>	-10 ... 55
<b>Protection rating</b>	IP 65 and IP 67
<b>Fastening modes</b>	back slot or to the top and lower end by rotating brackets SFB E180 (optional)
<b>Cross section (mm)</b>	28 x 30



Emitter 5 poles

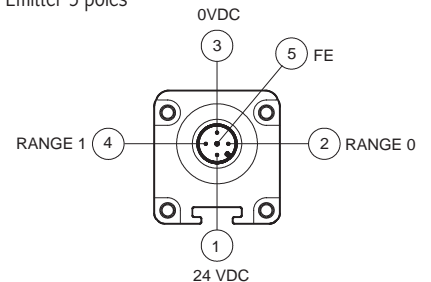

Receiver 8 poles

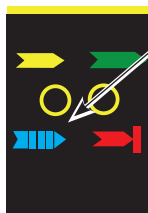
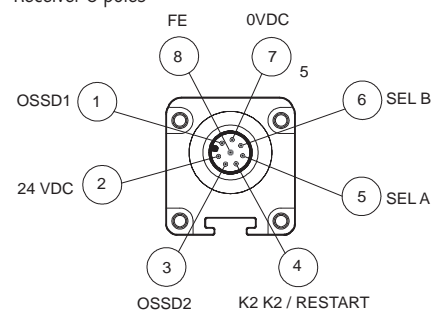

On the receivers of 14 mm resolution and H models a blue LED turns ON when the received beam signal intensity is weak.

During the alignment operations, checking the presence of the blue led weak signal is helpful. Upon completion of alignment and during normal operation, this LED must be off.



Safety level:

# TYPE 4

SIL 3 – SILCL 3  
PL e – Cat. 4

# EOS4 X / XH

WITH BUILT-IN CONTROL FUNCTIONS

## X Models 14 mm resolution - Max. range: selectable 3 or 6 m



Resolution 14 mm	EOS4 151 X	EOS4 301 X	EOS4 451 X	EOS4 601 X	EOS4 751 X	EOS4 901 X	EOS4 1051 X	EOS4 1201 X	EOS4 1351 X	EOS4 1501 X	EOS4 1651 X	EOS4 1801 X
Ordering codes	1310010	1310011	1310012	1310013	1310014	1310015	1310016	1310017	1310018	1310019	1310072	1310073
Protected height (mm)	160	310	460	610	760	910	1060	1210	1360	1510	1660	1810
Num. of beams	15	30	45	60	75	90	105	120	135	150	165	180
Overall height (mm)	213	363	513	663	813	963	1113	1263	1413	1563	1713	1863

## X Models - Max. range: selectable 4 or 12 m

### XH Models - Max. range: selectable 10 or 20 m



Resolution 20 mm	EOS4 152XH	EOS4 302XH	EOS4 452XH	EOS4 602XH	EOS4 752XH	EOS4 902XH	EOS4 1052XH	EOS4 1202XH	EOS4 1352XH	EOS4 1502XH	EOS4 1652XH	EOS4 1802XH
Ordering codes	1310160	1310161	1310162	1310163	1310164	1310165	1310166	1310167	1310168	1310169	1310182	1310183
Protected height (mm)	160	310	460	610	760	910	1060	1210	1360	1510	1660	1810
Num. of beams	15	30	45	60	75	90	105	120	135	150	165	180
Overall height (mm)	213	363	513	663	813	963	1113	1263	1413	1563	1713	1863



Resolution 30 mm	EOS4 153 X	EOS4 253 X	EOS4 303 X	EOS4 453 X	EOS4 603 X	EOS4 753 X	EOS4 903 X	EOS4 1053 X	EOS4 1203 X	EOS4 1353 X	EOS4 1503 X	EOS4 1653 X	EOS4 1803 X
Ordering codes	1310210	1311200	1310211	1310212	1310213	1310214	1310215	1310216	1310217	1310218	1310219	1310272	1310273
Resolution 30 mm	EOS4 153XH	-	EOS4 303XH	EOS4 453XH	EOS4 603XH	EOS4 753XH	EOS4 903XH	EOS4 1053XH	EOS4 1203XH	EOS4 1353XH	EOS4 1503XH	EOS4 1653XH	EOS4 1803XH
Ordering codes	1310260	-	1310261	1310262	1310263	1310264	1310265	1310266	1310267	1310268	1310269	1310282	1310283
Protected height (mm)	160	260	310	460	610	760	910	1060	1210	1360	1510	1660	1810
Num. of beams	8	13	16	23	31	38	46	53	61	68	76	83	91
Overall height (mm)	213	313	363	513	663	813	963	1113	1263	1413	1563	1713	1863



Resolution 40 mm	EOS4 154 X	EOS4 254 X	EOS4 304 X	EOS4 454 X	EOS4 604 X	EOS4 754 X	EOS4 904 X	EOS4 1054 X	EOS4 1204 X	EOS4 1354 X	EOS4 1504 X	EOS4 1654 X	EOS4 1804 X
Ordering codes	1310310	1311209	1310311	1310312	1310313	1310314	1310315	1310316	1310317	1310318	1310319	1310318	1310319
Resolution 40 mm	EOS4 154XH	-	EOS 304XH	EOS4 454XH	EOS4 604XH	EOS4 754XH	EOS4 904XH	EOS4 1054XH	EOS4 1204XH	EOS4 1354XH	EOS4 1504XH	EOS4 1654XH	EOS4 1803XH
Ordering codes	1310360	-	1310361	1310362	1310363	1310364	1310365	1310366	1310367	1310368	1310369	1310382	1310383
Protected height (mm)	160	260	310	460	610	760	910	1060	1210	1360	1510	1660	1810
Num. of beams	6	9	11	16	21	26	31	36	41	46	51	56	61
Overall height (mm)	213	313	363	513	663	813	963	1113	1263	1413	1563	1713	1863

## TYPE 4 SAFETY LIGHT CURTAIN

### EOS4 X / XH WITH BUILT-IN CONTROL FUNCTIONS

**X Models - Max. range: selectable 4 or 12 m**

**XH Models - Max. range: selectable 10 or 20 m**



Resolution 50 mm	EOS4 155 X	EOS4 305 X	EOS4 455 X	EOS4 605 X	EOS4 755 X	EOS4 905 X	EOS4 1055 X	EOS4 1205 X	EOS4 1355 X	EOS4 1505 X	EOS4 1655 X	EOS4 1805 X
Ordering codes	1310410	1310411	1310412	1310413	1310414	1310415	1310416	1310417	1310418	1310419	1310472	1310473
Resolution 50 mm	EOS4 155XH	EOS4 305XH	EOS4 455XH	EOS4 605XH	EOS4 755XH	EOS4 905XH	EOS4 1055XH	EOS4 1205XH	EOS4 1355XH	EOS4 1505XH	EOS4 1655XH	EOS4 1805XH
Ordering codes	1310460	1310461	1310462	1310463	1310464	1310465	1310466	1310467	1310468	1310469	1310482	1310483
Protected height (mm)	160	310	460	610	760	910	1060	1210	1360	1510	1660	1810
Num. of beams	4	8	12	16	20	24	28	32	36	40	44	48
Overall height (mm)	213	363	513	663	813	963	1113	1263	1413	1563	1713	1863



Resolution 90 mm	EOS4 309 X	EOS4 459 X	EOS4 609 X	EOS4 759 X	EOS4 909 X	EOS4 1059 X	EOS4 1209 X	EOS4 1359 X	EOS4 1509 X	EOS4 1659 X	EOS4 1809 X
Ordering codes	1310511	1310512	1310513	1310514	1310515	1310516	1310517	1310518	1310519	1310572	1310573
Resolution 90 mm	EOS4 309XH	EOS4 459XH	EOS4 609XH	EOS4 759XH	EOS4 909XH	EOS4 1059XH	EOS4 1209XH	EOS4 1359XH	EOS4 1509XH	EOS4 1659XH	EOS4 1809XH
Ordering codes	1310561	1310562	1310563	1310564	1310565	1310566	1310567	1310568	1310569	1310582	1310583
Protected height (mm)	310	460	610	760	910	1060	1210	1360	1510	1660	1810
Num. of beams	4	6	8	10	12	14	16	18	20	22	24
Overall height (mm)	363	513	663	813	963	1113	1263	1413	1563	1713	1863



2, 3, 4 beams	EOS4 2B X	EOS4 3B X	EOS4 4B X
Ordering codes	1310610	1310611	1310612
2, 3, 4 beams	EOS4 2B XH	EOS4 3B XH	EOS4 4B XH
Ordering codes	1310660	1310661	1310662
Num. of beams	2	3	4
Beams spacing (mm)	500	400	300
Protected height (mm)	510	810	910
Overall height (mm)	653	953	1053

► "ACCESSORIES" on page 69



# EOS4 XM / XS / XS2

## MASTER/SLAVE MODELS WITH BUILT-IN CONTROL FUNCTIONS

### MASTER/SLAVE MODELS

Master, Slave models permit series connection of up to three light curtains and combined detection of hand and presence of a person or of more sides of the machine, with the following major benefits:

- A single pair of safety outputs.
- No interference between light curtains installed adjacent to one another.

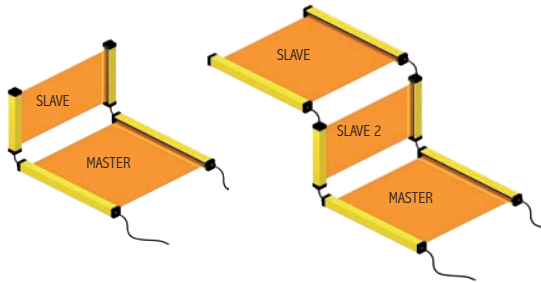

#### EXAMPLES OF SERIES CONNECTION OF MASTER AND SLAVE LIGHT CURTAINS

**Any Master model can be used together with any Slave model.**

All electrical connections are made using M12 5-pole connectors, except for Master receivers which necessitate the adoption of M12 8-pole connectors.

Pre-wired cables with twin connectors are available for the connection between Master and Slave.

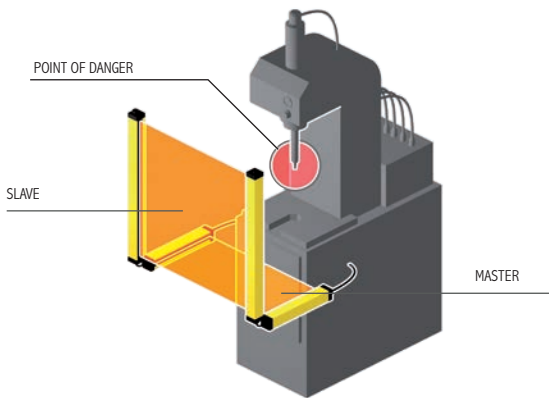

#### EXAMPLES OF SERIES CONNECTION OF MASTER AND SLAVE LIGHT CURTAINS

Master light curtain is placed horizontally for detection of the person and Slave light curtain is placed vertically to detect fingers or hands.

The arrangement can be reversed to have the Master light curtain vertical for finger and hand detection and the Slave light curtain horizontally for detecting the presence of a person.

The application shown is one of the most common: horizontal curtains are used to prevent the operator from being undetected in the space between vertical light curtain and dangerous machine, upon system start-up or restarting.

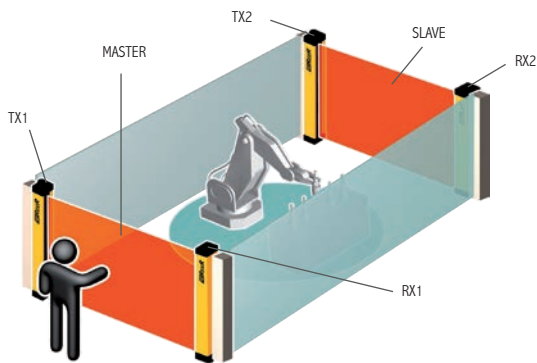

#### EXAMPLE OF SERIES CONNECTION OF MASTER AND SLAVE LIGHT CURTAINS FOR PROTECTION OF TWO SIDES OF THE MACHINE

On EOS4 X the connecting cable across Master and Slave is a standard (unshielded) cable up to 50 meter long.

Thus, two series connected curtains may be located one at the front of the machine and the other at the rear, with a single connection to the machine power and control circuitry.

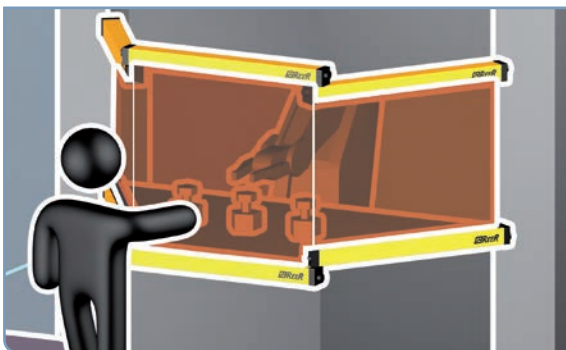

#### EXAMPLE OF SERIES CONNECTION OF ONE MASTER AND TWO SLAVE LIGHT CURTAINS FOR THE PROTECTION OF THREE SIDES OF THE MACHINE

Benefit: unimpeded operator access to work area from front and sides.

## EOS4 XM / XS / XS2

### MASTER/SLAVE MODELS WITH BUILT-IN CONTROL FUNCTIONS

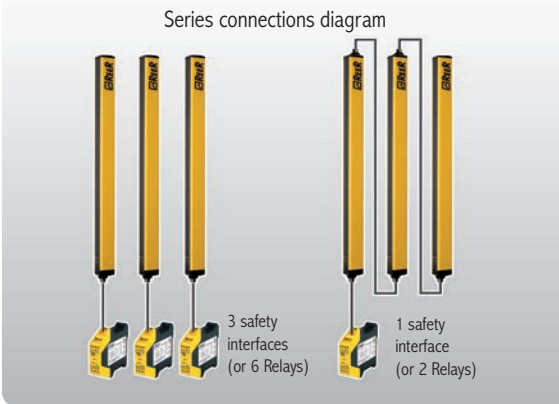

Series connections diagram

3 safety interfaces (or 6 Relays)

1 safety interface (or 2 Relays)

Benefit:  
with three standard curtains it will be necessary to use and wire up 3 safety interfaces or 6 contactors.

With the master, slave solution having 3 series light curtains it will be enough to use and wire up only 1 safety interface or 2 contactors.

## MASTER/SLAVE MODELS

Max. range: selectable 3 or 6 m

Resolution		EOS4 301 XM	EOS4 451 XM	EOS4 601 XM	EOS4 751 XM	EOS4 901 XM	EOS4 1051 XM	EOS4 1201 XM	EOS4 1351 XM	EOS4 1501 XM	EOS4 1651 XM	EOS4 1801 XM
<b>MASTER</b>	-											
Resolution 14 mm												
Ordering codes	-	1310021	1310022	1310023	1310024	1310025	1310026	1310027	1310028	1310029	1310074	1310075
<b>SLAVE</b>	EOS4 151 XS	EOS4 301 XS	EOS4 451 XS	EOS4 601 XS	EOS4 751 XS	EOS4 901 XS	EOS4 1051 XS	EOS4 1201 XS	EOS4 1351 XS	EOS4 1501 XS	EOS4 1651 XS	EOS4 1801 XS
Resolution 14 mm												
Ordering codes	1310030	1310031	1310032	1310033	1310034	1310035	1310036	1310037	1310038	1310039	1310076	1310076
<b>SLAVE 2</b>	-	EOS4 301 XS2	EOS4 451 XS2	EOS4 601 XS2	EOS4 751 XS2	EOS4 901 XS2	EOS4 1051 XS2	EOS4 1201 XS2	EOS4 1351 XS2	EOS4 1501 XS2	EOS4 1651 XS2	EOS4 1801 XS2
Resolution 14 mm												
Ordering codes	-	1310041	1310042	1310043	1310044	1310045	1310046	1310047	1310048	1310049	1310078	1310079
Protected height (mm)	160	310	460	610	760	910	1060	1210	1360	1510	1660	1810
Num. of beams	15	30	45	60	75	90	105	120	135	150	165	180
Overall height (mm) *	236.5	386.5	536.5	686.5	836.5	986.5	1136.5	1286.5	1436.5	1586.5	1736.5	1886.5

Max. range: selectable 4 or 12 m

Resolution		EOS 4 253 XM	EOS4 303 XM	EOS4 453 XM	EOS4 603 XM	EOS4 753 XM	EOS4 903 XM	EOS4 1053 XM	EOS4 1203 XM	EOS4 1353 XM	EOS4 1503 XM	EOS4 1653 XM	EOS4 1803 XM
<b>MASTER</b>	-												
Resolution 30 mm													
Ordering codes	-	1311206	1310221	1310222	1310223	1310224	1310225	1310226	1310227	1310228	1310229	1310274	1310275
<b>SLAVE</b>	EOS4 153 XS	EOS 4 253 XS	EOS4 303 XS	EOS4 453 XS	EOS4 603 XS	EOS4 753 XS	EOS4 903 XS	EOS4 1053 XS	EOS4 1203 XS	EOS4 1353 XS	EOS4 1503 XS	EOS4 1653 XS	EOS4 1803 XS
Resolution 30 mm													
Ordering codes	1310230	1311207	1310231	1310232	1310233	1310234	1310235	1310236	1310237	1310238	1310239	1310276	1310277
<b>SLAVE 2</b>	-	EOS 4 253 XM2	EOS4 303 XS2	EOS4 453 XS2	EOS4 603 XS2	EOS4 753 XS2	EOS4 903 XS2	EOS4 1053 XS2	EOS4 1203 XS2	EOS4 1353 XS2	EOS4 1503 XS2	EOS4 1653 XS2	EOS4 1803 XS2
Resolution 30 mm													
Ordering codes	-	1311208	1310241	1310242	1310243	1310244	1310245	1310246	1310247	1310248	1310249	1310278	1310279
Protected height (mm)	160	260	310	460	610	760	910	1060	1210	1360	1510	1660	1810
Num. of beams	8	13	16	23	31	38	46	53	61	68	76	83	91
Overall height (mm) *	236.5	336.5	386.5	536.5	686.5	836.5	986.5	1136.5	1286.5	1436.5	1586.5	1736.5	1886.5

# EOS4 XM / XS / XS2

## MASTER/SLAVE MODELS WITH BUILT-IN CONTROL FUNCTIONS

Max. range: selectable 4 or 12 m

<b>MASTER Resolution 40 mm</b>	-	EOS4 254 XM	EOS4 304 XM	EOS4 454 XM	EOS4 604 XM	EOS4 754 XM	EOS4 904 XM	EOS4 104 XM	EOS4 1204 XM	EOS4 1354 XM	EOS4 1504 XM	EOS4 1654 XM	EOS4 1804 XM
Ordering codes	-	1311210	1310321	1310322	1310323	1310324	1310325	1310326	1310327	1310328	1310329	1310374	1310375
<b>SLAVE Resolution 40 mm</b>	EOS4 154 XS	EOS 4 254 XS	EOS4 304 XS	EOS4 454 XS	EOS4 604 XS	EOS4 754 XS	EOS4 904 XS	EOS4 1054 XS	EOS4 1204 XS	EOS4 1354 XS	EOS4 1504 XS	EOS4 1654 XS	EOS4 1804 XS
Ordering codes	1310330	1311211	1310331	1310332	1310333	1310334	1310335	1310336	1310337	1310338	1310339	1310376	1310377
<b>SLAVE 2 Resolution 40 mm</b>	-	EOS4 254 XM2	EOS4 304 XS2	EOS4 454 XS2	EOS4 604 XS2	EOS4 754 XS2	EOS4 904 XS2	EOS4 1054 XS2	EOS4 1204 XS2	EOS4 1354 XS2	EOS4 1504 XS2	EOS4 1654 XS2	EOS4 1804 XS2
Ordering codes	-	1311212	1310341	1310342	1310343	1310344	1310345	1310346	1310347	1310348	1310349	1310378	1310379
Protected height (mm)	160	260	310	460	610	760	910	1060	1210	1360	1510	1660	1810
Num. of beams	6	9	11	16	21	26	31	36	41	46	51	56	61
Overall height (mm) *	236.5	336.5	386.5	536.5	686.5	836.5	986.5	1136.5	1286.5	1436.5	1586.5	1736.5	1886.5



<b>MASTER Resolution 50 mm</b>	-	EOS4 305 XM	EOS4 455 XM	EOS4 605 XM	EOS4 755 XM	EOS4 905 XM	EOS4 105 XM	EOS4 1205 XM	EOS4 1355 XM	EOS4 1505 XM	EOS4 1655 XM	EOS4 1805 XM
Ordering codes	-	1310421	1310422	1310423	1310424	1310425	1310426	1310427	1310428	1310429	1310474	1310475
<b>SLAVE Resolution 50 mm</b>	EOS4 155 XS	EOS4 305 XS	EOS4 455 XS	EOS4 605 XS	EOS4 755 XS	EOS4 905 XS	EOS4 1055 XS	EOS4 1205 XS	EOS4 1355 XS	EOS4 1505 XS	EOS4 1655 XS	EOS4 1805 XS
Ordering codes	1310430	1310431	1310432	1310433	1310434	1310435	1310436	1310437	1310438	1310439	1310476	1310477
<b>SLAVE 2 Resolution 50 mm</b>	-	EOS4 305 XS2	EOS4 455 XS2	EOS4 605 XS2	EOS4 755 XS2	EOS4 905 XS2	EOS4 1055 XS2	EOS4 1205 XS2	EOS4 1355 XS2	EOS4 1505 XS2	EOS4 1655 XS2	EOS4 1805 XS2
Ordering codes	-	1310441	1310442	1310443	1310444	1310445	1310446	1310447	1310448	1310449	1310478	1310479
Protected height (mm)	160	310	460	610	760	910	1060	1210	1360	1510	1660	1810
Num. of beams	4	8	12	16	20	24	28	32	36	40	44	48
Overall height (mm) *	236.5	386.5	536.5	686.5	836.5	986.5	1136.5	1286.5	1436.5	1586.5	1736.5	1886.5



# TYPE 4 SAFETY LIGHT CURTAIN

## EOS4 XM / XS / XS2

### MASTER/SLAVE MODELS WITH BUILT-IN CONTROL FUNCTIONS

Max. range: selectable 4 or 12 m



<b>MASTER Resolution 90 mm</b>	<b>EOS4 309 XM</b>	<b>EOS4 459 XM</b>	<b>EOS4 609 XM</b>	<b>EOS4 759 XM</b>	<b>EOS4 909 XM</b>	<b>EOS4 1059 XM</b>	<b>EOS4 1209 XM</b>	<b>EOS4 1359 XM</b>	<b>EOS4 1509 XM</b>	<b>EOS4 1659 XM</b>	<b>EOS4 1809 XM</b>
Ordering codes	<b>1310521</b>	<b>1310522</b>	<b>1310523</b>	<b>1310524</b>	<b>1310525</b>	<b>1310526</b>	<b>1310527</b>	<b>1310528</b>	<b>1310529</b>	<b>1310574</b>	<b>1310575</b>
<b>SLAVE Resolution 90 mm</b>	<b>EOS4 309 XS</b>	<b>EOS4 459 XS</b>	<b>EOS4 609 XS</b>	<b>EOS4 759 XS</b>	<b>EOS4 909 XS</b>	<b>EOS4 1059 XS</b>	<b>EOS4 1209 XS</b>	<b>EOS4 1359 XS</b>	<b>EOS4 1509 XS</b>	<b>EOS4 1659 XS</b>	<b>EOS4 1809 XS</b>
Ordering codes	<b>1310531</b>	<b>1310532</b>	<b>1310533</b>	<b>1310534</b>	<b>1310535</b>	<b>1310536</b>	<b>1310537</b>	<b>1310538</b>	<b>1310539</b>	<b>1310576</b>	<b>1310577</b>
<b>SLAVE 2 Resolution 90 mm</b>	<b>EOS4 309 XS2</b>	<b>EOS4 459 XS2</b>	<b>EOS4 609 XS2</b>	<b>EOS4 759 XS2</b>	<b>EOS4 909 XS2</b>	<b>EOS4 1059 XS2</b>	<b>EOS4 1209 XS2</b>	<b>EOS4 1359 XS2</b>	<b>EOS4 1509 XS2</b>	<b>EOS4 1659 XS2</b>	<b>EOS4 1809 XS2</b>
Ordering codes	<b>1310541</b>	<b>1310542</b>	<b>1310543</b>	<b>1310544</b>	<b>1310545</b>	<b>1310546</b>	<b>1310547</b>	<b>1310548</b>	<b>1310549</b>	<b>1310578</b>	<b>1310579</b>
Protected height (mm)	310	460	610	760	910	1060	1210	1360	1510	1660	1810
Num. of beams	4	6	8	10	12	14	16	18	20	22	24
Overall height (mm) *	386.5	536.5	686.5	836.5	986.5	1136.5	1286.5	1436.5	1586.5	1736.5	1886.5



<b>MASTER 2, 3, 4 beams</b>	<b>EOS4 2B XM</b>	<b>EOS4 3B XM</b>	<b>EOS4 4B XM</b>
Ordering codes	<b>1310620</b>	<b>1310621</b>	<b>1310622</b>
<b>SLAVE 2, 3, 4 beams</b>	<b>EOS4 2B XS</b>	<b>EOS4 3B XS</b>	<b>EOS4 4B XS</b>
Ordering codes	<b>1310630</b>	<b>1310631</b>	<b>1310632</b>
<b>SLAVE 2 2, 3, 4 beams</b>	<b>EOS4 2B XS2</b>	<b>EOS4 3B XS2</b>	<b>EOS4 4B XS2</b>
Ordering codes	<b>1310640</b>	<b>1310641</b>	<b>1310642</b>
Num. of beams	2	3	4
Beams spacing (mm)	500	400	300
Protected height (mm)	510	810	910
Overall height (mm)*	677	977	1077

\* On slave models, the overall height of the light curtain is the same of the standard model.  
On Master and Slave2, the total height of the light curtain is greater due to the addition of a secondary connector.

► "ACCESSORIES" on page 69

# EOS4

## DIMENSIONS (mm)

**EOS4 / EOS4 SLAVE**

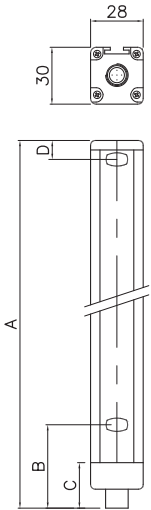

**EOS4 MASTER / EOS4 SLAVE 2**

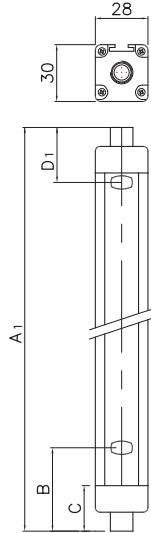

Model	2B	3B	4B
A	653	953	1053
A <sub>1</sub> (Master/Slave2)	677	977	1077
B	102		
C	29.5		
D	51		
D <sub>1</sub> (Master/Slave2)	75		

Model	150	250	300	450	600	750	900	1050	1200	1350	1500	1650	1800
A	213	313	363	513	663	813	963	1113	1263	1413	1563	1713	1863
A <sub>1</sub> (Master/Slave2)	236.5	336.5	386.5	536.5	686.5	836.5	986.5	1136.5	1286.5	1436.5	1586.5	1736.5	1886.5
B	61.5												
C	29.5												
D	11												
D <sub>1</sub> (Master/Slave 2)	34.5												
Mounting	Complete set of 4 LE type brackets included in the package								Complete set of 6 LE type brackets included in the package				



### WARNING!

Where the light curtain is subjected to strong vibrations (presses, textile looms, etc.) always use vibrations dampers SAV E (available as accessories) in order to prevent damaging the light curtain.

Where protections are to be placed over long distances or on several sides using deflection mirrors, it is advisable to use laser alignment aid LAD 4 to ensure simple, quick and perfect alignment of light curtains.

## ORDERING INFORMATION

**Each EOS4 light curtain comprises:**

Emitter and Receiver pair	CD-ROM containing the multi-language instruction manual complete with CE declaration of conformity
Brackets and inserts	Quick installation guide

## ACCESSORIES

**For EOS4 light curtains the following accessories, to be ordered separately, are available:**

AD SR Safety relays	▶ See page 183
FMC floor mounting columns	▶ See page 220
SP deflection mirrors	▶ See page 223
LAD laser alignment device	▶ See page 224
SAV E vibrations dampers	▶ See page 225
SFB swivel fixing brackets	▶ See page 226
Connectors	▶ See list hereunder:

**CONNECTORS (EOS4 A emitter and receiver / EOS4 X emitter)**

Model	Code	Description
CD 5	1330950	M12 straight connector 5 poles pre-wired, cable 5 m
CD 10	1330956	M12 straight connector 5 poles pre-wired, cable 10 m
CD 15	1330952	M12 straight connector 5 poles pre-wired, cable 15 m
CD 20	1330957	M12 straight connector 5 poles pre-wired, cable 20 m
CD 25	1330949	M12 straight connector 5 poles pre-wired, cable 25 m
CD 50	1330965	M12 straight connector 5 poles pre-wired, cable 50 m
CD 95	1330951	M12 90° angle connector 5 poles pre-wired, cable 5 m
CD 910	1330958	M12 90° angle connector 5 poles pre-wired, cable 10 m
CD 915	1330953	M12 90° angle connector 5 poles pre-wired, cable 15 m
CDM 9	1330954	M12 straight connector 5 poles with screw terminal, PG9 cable gland
CDM 99	1330955	M12 90° angle connector, 5 poles with screw terminal, PG9 cable gland

**CONNECTORS EOS4 (X receiver)**

Model	Code	Description
C8D 5	1330980	M12 straight connector 8 poles pre-wired, cable 5 m
C8D 10	1330981	M12 straight connector 8 poles pre-wired, cable 10 m
C8D 15	1330982	M12 straight connector 8 poles pre-wired, cable 15 m
C8D 25	1330967	M12 straight connector 8 poles pre-wired, cable 25 m
C8D 40	1440966	M12 straight connector 8 poles pre-wired, cable 40 m
C8D 95	1330983	M12 90° angle connector 8 poles pre-wired, cable 5 m
C8D 910	1330984	M12 90° angle connector 8 poles pre-wired, cable 10 m
C8D 915	1330985	M12 90° angle connector 8 poles pre-wired, cable 15 m
C8DM 11	1330978	M12 straight connector 8 poles with screw terminal, PG9/11 cable gland
C8DM 911	1330979	M12 90° angle connector 8 poles with screw terminal, PG9/11 cable gland

**CONNECTION BETWEEN MASTER AND SLAVE**

Model	Code	Description
CDS 03	1330990	0,3 m pre-wired cable with 2 straight connectors M12 5-pole
CIBE 3	1360960	3 m pre-wired cable with 2 straight connectors M12 5-pole
CIBE 5	1360961	5 m pre-wired cable with 2 straight connectors M12 5-pole
CIBE 10	1360962	10 m pre-wired cable with 2 straight connectors M12 5-pole
CIBE 25	1360963	25 m pre-wired cable with 2 straight connectors M12 5-pole



# ADMIRAL





## ADMIRAL

The Admiral Type 4 family of safety light curtains is the ideal solution for the protection of the majority of high-risk industrial applications.

### Its features include:

- Extremely easy connection and installation, thanks to the M12 connectors and the use of standard cables up to 100 m.
- Integration of the main safety functions, including self-monitoring of the safety circuits and, for the AX models, the external device monitoring (EDM) and the Start / Restart interlock functions.
- The utmost reliability in the field, thanks to the rugged construction and to the high level of immunity to external interference (optical, EMC, etc.).
- The breadth of the range, including Master / Slave models for cascade connection of two light curtains, models with floating blanking, and the widest variety of heights and resolutions.

Models with 2, 3 and 4 beams Long Range, Max. 60 or 80 meters available.

Special versions in WT/WTH watertight enclosure available on request.

► [See page 197](#)

Admiral light curtains may be connected to the dedicated safety interfaces series AD SR, or directly to contactors actuated and controlled by the light curtain, or to MOSAIC or to suitable commercial safety modules or safety PLCs.

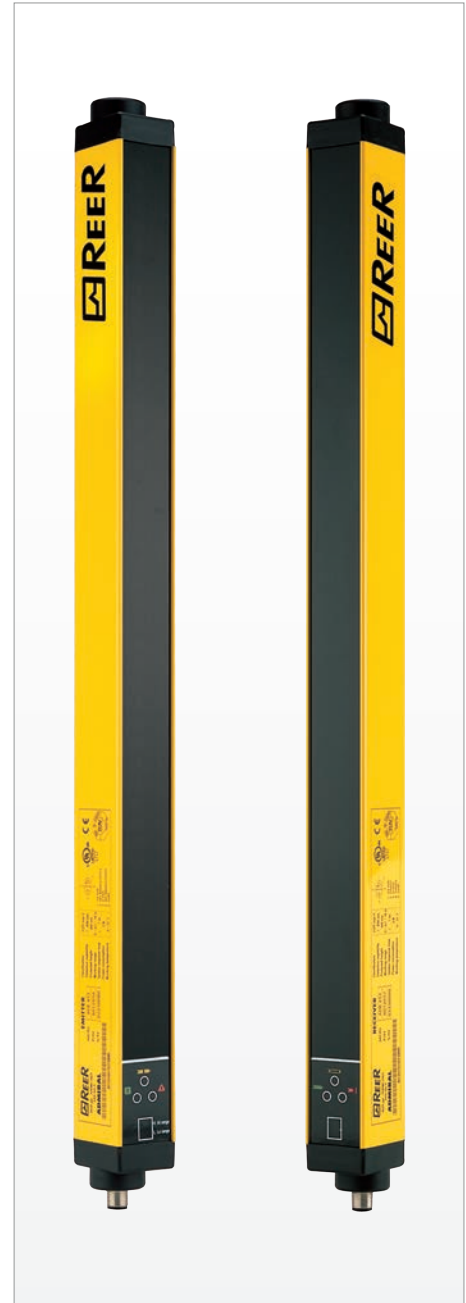
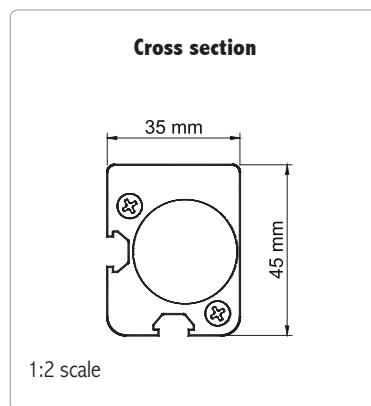

### Safety level: **Type 4 – SIL 3 – SILCL 3 – PL e – Cat. 4**

- 2006/42/CE “Machinery Directive”
- 2004/108/CE “Electromagnetic Compatibility (EMC)”
- 2006/95/CE “Low Voltage Directive (LVD)”
- IEC/EN 61496-1 Ed. 2.1 and IEC/TS 61496-2 Ed. 2 “Safety of machinery - Electro-sensitive protective equipment- General requirements and tests”
- EN ISO 13849-1 “Safety of machinery – Safety-related parts of control systems – Part 1: General principles for design”
- IEC/EN 62061 “Safety of machinery – Functional safety of safety-related electrical, electronic and programmable electronic control systems”
- IEC 61508 “Functional safety of electrical/electronic/programmable electronic safety-related systems”
- IEC/TS 62046 Ed. 2 “Safety of machinery – Application of protective equipment to detect the presence of persons”
- UL (C+US) mark for USA and Canada
- ANSI / UL 1998 “Safety Software in Programmable Components”.



### THE ADMIRAL RANGE

ADMIRAL AD	ADMIRAL AX	ADMIRAL AXM - AXS	ADMIRAL AX LR Long Range	ADMIRAL AX LR DB	ADMIRAL AX BK
Automatic Start/Restart	Built-in manual or automatic restart, selectable	Master and Slave models for serial connection of two light curtains even of different height and resolution	Max. range 60 m	Special version of the Admiral Long Range features an innovative Dual Beam System  See <b>NOTE 1</b>	Built-in functions of floating blanking with 5 selectable configurations  See <b>NOTE 2</b>
The ideal light curtain for a simple interface with safety modules or PLC	The ideal light curtain for directly controlling and monitoring the circuits of the machine, without the need for external safety modules	Ideal solution for connecting two light curtains in series to perform a combined detection of the hand and of the presence of the person or of two different sides of the machine	Ideal light curtain for large size protection applications, also on several sides using deflection mirrors	Ideal light curtain in outdoor applications or in harsh environments for decreasing the sensitivity of the light curtain to small objects that could interrupt the light link, i.e. birds or leaves but also heavy rain or snow.	The ideal light curtain for protecting press brakes, automatic machines and robotised areas, where the material being processed or moving parts of the machine cross the field protected by the light curtain
Start/Restart interlock and EDM via external AD SR1 interface	Feedback input for control of external relays (EDM).				Start/Restart interlock and EDM via external AD SR1 interface
Electrical connections: M12 5-pole connectors for emitter and receiver	Electrical connections: M12 5-pole for emitter M12 8-pole for receiver  <b>ATTENTION:</b> the electrical connections for the Master and Slave models are described in the section dedicated. (See page 76)				
Max. range: selectable 2 or 5 m for 14 mm resolution selectable 6 or 18 m for 20, 30, 40, 50, 90 mm resolutions and 2, 3, 4 beams			Max. range selectable 22 or 60 m 2, 3, 4 beams	Max. range selectable 25 or 80 m 2, 3 dual beams	Max. range: selectable 2 or 5 m for 14 mm resolution selectable 6 or 18 m for 20, 30, 40, 50, 90 mm resolutions
Types of detection: resolution 14 mm for finger detection resolution 20, 30, 40 mm for hand detection resolution 50, 90 mm for detection of the body in a hazardous area 2, 3, 4 beams for detection of the body in access control			Types of detection: 2, 3, 4 beams for detection of the body in access control	Types of detection: 2, 3 beams for detection of the body in access control	Types of detection: resolution 14 mm for finger detection resolution 20, 40 mm for hand detection resolution 90 mm for detection of the body in a hazardous area
2 self-testing solid state PNP safety outputs protected against short circuits and overloads					

**NOTE 1** Available with heated IP 67 WTH case for outdoor use (see page 197).

**NOTE 2:** With the blanking models with 14 and 20 mm resolution, it is also possible to have the Master/Slave function (see page 80).



Admiral Long Range with the innovative Dual Beam system



IP 67 watertight enclosure, with heating system

# ADMIRAL AD

WITH AUTOMATIC START/RESTART

## MAIN FEATURES

- Automatic Start/Restart
- Max. range: up to 5 m for 14 mm resolution models, up to 18 m for other models.
- Two self-testing solid state PNP safety outputs.
- All connections and configurations by means of M12 connectors.
- Use of unshielded cables up to 100 m.
- Suppression of optical interference by means of range selection.
- Start/Restart interlock and EDM via external AD SR1 interface.

## TECHNICAL FEATURES

<b>Safety level</b>	Type 4 according to IEC/TS 61496-2 SIL 3 – SILCL 3 according to IEC 61508 - IEC 62061 PL e – Cat. 4 according to ISO 13849-1
<b>Protected heights (mm)</b>	160 ... 1810
<b>Resolutions (mm)</b>	14, 20, 30, 40, 50, 90
<b>Number of beams for body detection in access control</b>	2, 3, 4
<b>Max. range (m)</b>	selectable 2 or 5 for 14 mm resolution selectable 6 or 18 for 20, 30, 40, 50, 90 mm resolutions and 2, 3, 4 beams
<b>Response time (ms)</b>	6 ... 27
<b>Safety outputs</b>	2 PNP - 500 mA at 24 VDC with short-circuit, overload, polarity reversal protection
<b>Signalling</b>	seven-segment display and LEDs for light curtain's status and diagnostic
<b>Start/Restart</b>	automatic
<b>Power supply (VDC)</b>	24 ± 20%
<b>Electrical connections</b>	M12 5-pole for emitter and receiver
<b>Max. cable length (m)</b>	100
<b>Operating temperature (°C)</b>	0 ... 55
<b>Protection rating</b>	IP 65
<b>Fastening modes</b>	back slot, side slot or to the top and lower end with swivel brackets
<b>Cross section (mm)</b>	35 x 45

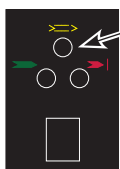

On the receivers of all models, a yellow LED turns ON when the received beam signal intensity is weak.

During the alignment operations, checking the presence of the yellow led weak signal is helpful. Upon completion of alignment and during normal operation, this LED must be off.

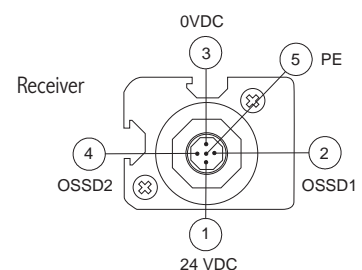
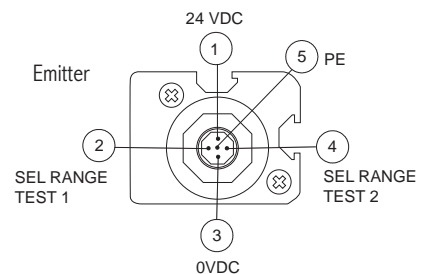

Safety level:

**TYPE 4**

SIL 3 – SILCL 3  
PL e – Cat. 4



### Models with 14 mm resolution - Max. range: selectable 2 or 5 m



Resolution 14 mm	AD 151	AD 301	AD 451	AD 601	AD 751	AD 901	AD 1051	AD 1201	AD 1351	AD 1501	AD 1651	AD 1801
Ordering codes	1330000	1330001	1330002	1330003	1330004	1330005	1330006	1330007	1330008	1330009	1330010	1330011
Protected height (mm)	160	310	460	610	760	910	1060	1210	1360	1510	1660	1810
Num. of beams	15	30	45	60	75	90	105	120	135	150	165	180
Overall height (mm)	261	411	561	711	861	1011	1161	1311	1461	1611	1761	1911

### Models with 20 - 30 - 40 - 50 - 90 mm resolution and 2 - 3 - 4 beams - Max. range: selectable 6 or 18 m



Resolution 20 mm	AD 152	AD 302	AD 452	AD 602	AD 752	AD 902	AD 1052	AD 1202	AD 1352	AD 1502	AD 1652	AD 1802
Ordering codes	1330100	1330101	1330102	1330103	1330104	1330105	1330106	1330107	1330108	1330109	1330110	1330111
Protected height (mm)	160	310	460	610	760	910	1060	1210	1360	1510	1660	1810
Num. of beams	15	30	45	60	75	90	105	120	135	150	165	180
Overall height (mm)	261	411	561	711	861	1011	1161	1311	1461	1611	1761	1911



Resolution 30 mm	AD 153	AD 303	AD 453	AD 603	AD 753	AD 903	AD 1053	AD 1203	AD 1353	AD 1503	AD 1653	AD 1803
Ordering codes	1330200	1330201	1330202	1330203	1330204	1330205	1330206	1330207	1330208	1330209	1330210	1330211
Protected height (mm)	160	310	460	610	760	910	1060	1210	1360	1510	1660	1810
Num. of beams	8	16	24	32	40	48	56	64	72	80	88	96
Overall height (mm)	261	411	561	711	861	1011	1161	1311	1461	1611	1761	1911



Resolution 40 mm	AD 304	AD 454	AD 604	AD 754	AD 904	AD 1054	AD 1204	AD 1354	AD 1504	AD 1654	AD 1804
Ordering codes	1330301	1330302	1330303	1330304	1330305	1330306	1330307	1330308	1330309	1330310	1330311
Protected height (mm)	310	460	610	760	910	1060	1210	1360	1510	1660	1810
Num. of beams	10	15	20	25	30	35	40	45	50	55	60
Overall height (mm)	411	561	711	861	1011	1161	1311	1461	1611	1761	1911



Resolution 50 mm	AD 305	AD 455	AD 605	AD 755	AD 905	AD 1055	AD 1205	AD 1355	AD 1505	AD 1655	AD 1805
Ordering codes	1330401	1330402	1330403	1330404	1330405	1330406	1330407	1330408	1330409	1330410	1330411
Protected height (mm)	310	460	610	760	910	1060	1210	1360	1510	1660	1810
Num. of beams	8	12	16	20	24	28	32	36	40	44	48
Overall height (mm)	411	561	711	861	1011	1161	1311	1461	1611	1761	1911



Resolution 90 mm	AD 309	AD 459	AD 609	AD 759	AD 909	AD 1059	AD 1209	AD 1359	AD 1509	AD 1659	AD 1809
Ordering codes	1330501	1330502	1330503	1330504	1330505	1330506	1330507	1330508	1330509	1330510	1330511
Protected height (mm)	310	460	610	760	910	1060	1210	1360	1510	1660	1810
Num. of beams	5	7	9	11	13	15	17	19	21	23	25
Overall height (mm)	411	561	711	861	1011	1161	1311	1461	1611	1761	1911



2, 3, 4 beams	AD 2B	AD 3B	AD 4B
Ordering codes	1330600	1330601	1330602
Num. of beams	2	3	4
Beam spacing (mm)	500	400	300
Protected height (mm)	510	810	910
Overall height (mm)	711	1011	1111

# ADMIRAL AX

WITH BUILT-IN CONTROL FUNCTIONS

## MAIN FEATURES

- Two self-testing solid state PNP safety outputs.
- Built-in start/restart interlock, selectable.
- Max. range: up to 5 m for 14 mm resolution; up to 18 m for other resolution models; 60 m and 80 m for Long Range models as illustrated in the following table.
- Feedback input for external device monitoring (EDM).
- All connections and configurations by means of M12 connectors.
- Use of unshielded cables up to 100 m.
- Suppression of optical interference by means of range selection.
- Master and Slave models for serial connection of 2 light curtains.
- Maximum length of the connections between Master and Slave: 50 metres, with unshielded cables.

## TECHNICAL FEATURES

<b>Safety level</b>	Type 4 according to IEC/TS 61496-2 SIL 3 – SILCL 3 according to IEC 61508 - IEC 62061 PL e – Cat. 4 according to ISO 13849-1
<b>Protected heights (mm)</b>	160 ... 1810
<b>Resolutions (mm)</b>	14, 20, 30, 40, 50, 90
<b>Number of beams for body detection in access control</b>	2, 3, 4
<b>Max. range (m)</b>	selectable 2 or 5 for 14 mm resolution selectable 6 or 18 for 20, 30, 40, 50, 90 mm resolutions and 2, 3, 4 beams selectable 22 or 60 for 2, 3, 4 beams Long Range selectable 25 or 80 for 2, 3 beams Long Range DB
<b>Response time (ms)</b>	6 ... 27
<b>Safety outputs</b>	2 PNP auto-controlled – 500 mA at 24 VDC with short-circuit, overload, polarity reversal protection
<b>Signalling</b>	seven-segment display and LEDs for light curtain's status and diagnostic
<b>Start/Restart</b>	selectable automatic or manual
<b>External Device Monitoring</b>	external device monitoring feedback input with enabling, selectable
<b>Power supply (VDC)</b>	24 ± 20%
<b>Electrical connections for AX and AX Master</b>	M12 5-pole for emitter M12 8-pole for receiver
<b>Electrical connections for Master and Slave</b>	M12 5-pole for emitter and receiver
<b>Max. cable length (m)</b>	100 (50 between master and slave)
<b>Operating temperature (°C)</b>	0 ... 55
<b>Protection rating</b>	IP 65
<b>Fastening modes</b>	back slot, side slot or to the top and lower end with swivel brackets
<b>Cross section (mm)</b>	35 x 45

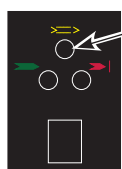
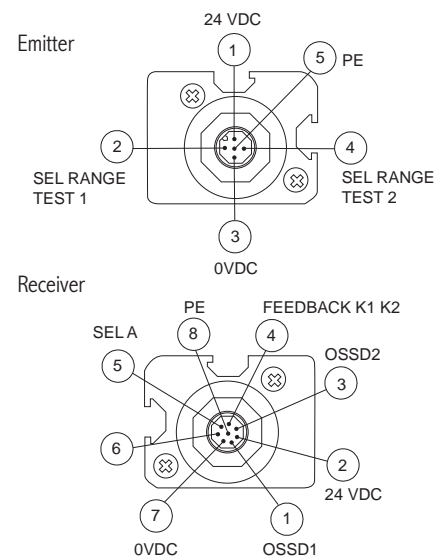

On the receiver, also for these models, a yellow LED turns ON when the received beam signal intensity is weak.



Safety Level

# TYPE 4

SIL 3 – SILCL 3  
PL e – Cat. 4

#### Models with 14 mm resolution - Max. range: selectable 2 or 5 m



Resolution 14 mm	AX 151	AX 301	AX 451	AX 601	AX 751	AX 901	AX 1051	AX 1201	AX 1351	AX 1501	AX 1651	AX 1801
Ordering codes	1334000	1334001	1334002	1334003	1334004	1334005	1334006	1334007	1334008	1334009	1334010	1334011
Protected height (mm)	160	310	460	610	760	910	1060	1210	1360	1510	1660	1810
Num. of beams	15	30	45	60	75	90	105	120	135	150	165	180
Overall height (mm)	261	411	561	711	861	1011	1161	1311	1461	1611	1761	1911

#### Models with 20 - 30 - 40 - 50 - 90 mm resolution and 2 - 3 - 4 beams - Max. range: selectable 6 or 18 m



Resolution 20 mm	AX 152	AX 302	AX 452	AX 602	AX 752	AX 902	AX 1052	AX 1202	AX 1352	AX 1502	AX 1652	AX 1802
Ordering codes	1334100	1334101	1334102	1334103	1334104	1334105	1334106	1334107	1334108	1334109	1334110	1334111
Protected height (mm)	160	310	460	610	760	910	1060	1210	1360	1510	1660	1810
Num. of beams	15	30	45	60	75	90	105	120	135	150	165	180
Overall height (mm)	261	411	561	711	861	1011	1161	1311	1461	1611	1761	1911



Resolution 30 mm	AX 153	AX 303	AX 453	AX 603	AX 753	AX 903	AX 1053	AX 1203	AX 1353	AX 1503	AX 1653	AX 1803
Ordering codes	1334200	1334201	1334202	1334203	1334204	1334205	1334206	1334207	1334208	1334209	1334210	1334211
Protected height (mm)	160	310	460	610	760	910	1060	1210	1360	1510	1660	1810
Num. of beams	8	16	24	32	40	48	56	64	72	80	88	96
Overall height (mm)	261	411	561	711	861	1011	1161	1311	1461	1611	1761	1911



Resolution 40 mm	AX 304	AX 454	AX 604	AX 754	AX 904	AX 1054	AX 1204	AX 1354	AX 1504	AX 1654	AX 1804
Ordering codes	1334301	1334302	1334303	1334304	1334305	1334306	1334307	1334308	1334309	1334310	1334311
Protected height (mm)	310	460	610	760	910	1060	1210	1360	1510	1660	1810
Num. of beams	10	15	20	25	30	35	40	45	50	55	60
Overall height (mm)	411	561	711	861	1011	1161	1311	1461	1611	1761	1911



Resolution 50 mm	AX 305	AX 455	AX 605	AX 755	AX 905	AX 1055	AX 1205	AX 1355	AX 1505	AX 1655	AX 1805
Ordering codes	1334401	1334402	1334403	1334404	1334405	1334406	1334407	1334408	1334409	1334410	1334411
Protected height (mm)	310	460	610	760	910	1060	1210	1360	1510	1660	1810
Num. of beams	8	12	16	20	24	28	32	36	40	44	48
Overall height (mm)	411	561	711	861	1011	1161	1311	1461	1611	1761	1911



Resolution 90 mm	AX 309	AX 459	AX 609	AX 759	AX 909	AX 1059	AX 1209	AX 1359	AX 1509	AX 1659	AX 1809
Ordering codes	1334501	1334502	1334503	1334504	1334505	1334506	1334507	1334508	1334509	1334510	1334511
Protected height (mm)	310	460	610	760	910	1060	1210	1360	1510	1660	1810
Num. of beams	5	7	9	11	13	15	17	19	21	23	25
Overall height (mm)	411	561	711	861	1011	1161	1311	1461	1611	1761	1911

#### LR Models - Max. range: selectable 22 or 60 m

#### LR DB Models - Max. range: selectable 25 or 80 m



2, 3, 4 beams	AX 2B	AX 3B	AX 4B	AX 2B LR	AX 3B LR	AX 4B LR	AX 2B LR DB	AX 3B LR DB
Ordering codes	1334600	1334601	1334602	1334603	1334604	1334605	1334606	1334607
Num. of beams	2	3	4	2	3	4	2	3
Beam spacing (mm)	500	400	300	500	400	300	500	400
Protected height (mm)	510	810	910	510	810	910	510	810
Overall height (mm)	711	1011	1111	711	1011	1111	772	1072

► "ACCESSORIES" on page 84

## ADMIRAL AX

### MASTER/SLAVE MODELS WITH BUILT-IN CONTROL FUNCTIONS

Master/Slave models permit series connection of two light curtains achieving two main advantages:

- A single pair of safety outputs
- No interference between light curtains installed adjacent to one another.

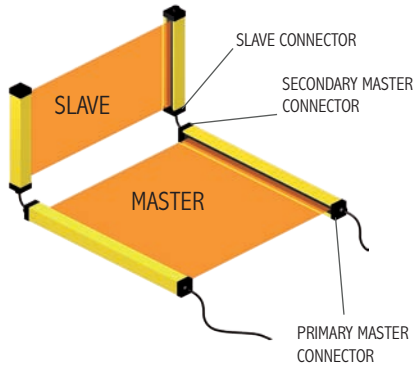

#### EXAMPLE OF SERIAL CONNECTION BETWEEN A MASTER LIGHT CURTAIN AND A SLAVE LIGHT CURTAIN

It is possible to combine any Master model with any Slave model.

All the electrical connections are made using M12 5-pole connectors, except for the Master receiver, which requires an M12 8-pole connector.

Pre-wired cables with twin connectors are available for the connection between Master and Slave.

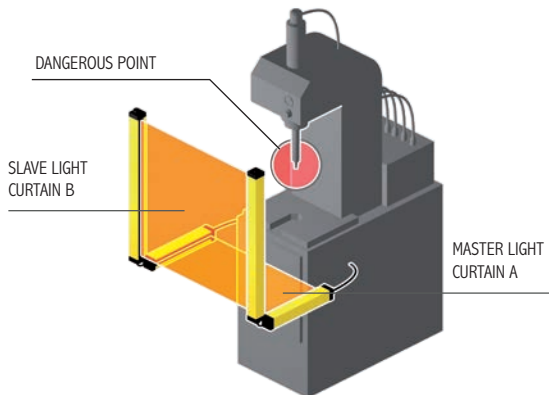

#### EXAMPLE OF SERIAL CONNECTION BETWEEN A MASTER LIGHT CURTAIN AND A SLAVE LIGHT CURTAIN

The Master light curtain is positioned horizontally for detecting the presence of the person while the vertical Slave light curtain detects fingers or hands.

However, it is possible to invert the combination and have the Master light curtain positioned vertically for protection of fingers or hands and the Slave light curtain horizontally for detecting the presence of the person.

The application illustrated is one of the most common: the horizontal light curtain is used for eliminating the possibility for the operator not to be detected between the vertical light curtain and the dangerous machine at the start or restart of the system.

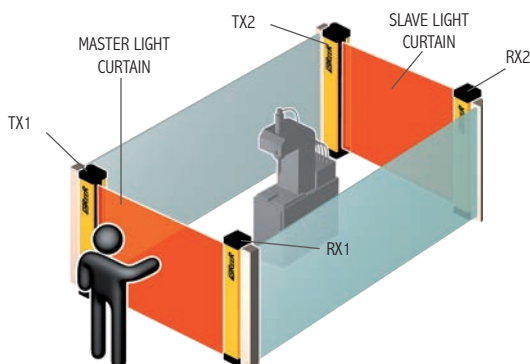

#### EXAMPLE OF SERIAL CONNECTION BETWEEN A MASTER LIGHT CURTAIN AND A SLAVE LIGHT CURTAIN FOR PROTECTION OF 2 SIDES OF THE MACHINE

In the Admiral AX light curtains the connection cable between Master and Slave is a standard unshielded cable that can be up to 50 meters long.

This characteristic allows the application of 2 light curtains in series positioned on the front and on the back of the dangerous machine, with a single connection towards the power and control circuits of the machine.

## ADMIRAL AX

### MASTER/SLAVE MODELS WITH BUILT-IN CONTROL FUNCTIONS

#### MASTER/SLAVE Models with 14 mm resolution - Max. range: selectable 2 or 5



<b>MASTER Resolution 14 mm</b>	-	<b>AX 301M</b>	<b>AX 451M</b>	<b>AX 601M</b>	<b>AX 751M</b>	<b>AX 901M</b>	<b>AX 1051M</b>	<b>AX 1201M</b>	<b>AX 1501M</b>
Ordering codes	-	<b>1334021</b>	<b>1334022</b>	<b>1334023</b>	<b>1334024</b>	<b>1334025</b>	<b>1334026</b>	<b>1334027</b>	<b>1334029</b>
<b>SLAVE Resolution 14 mm</b>	<b>AX 151S</b>	<b>AX 301S</b>	<b>AX 451S</b>	<b>AX 601S</b>	<b>AX 751S</b>	<b>AX 901S</b>	<b>AX 1051S</b>	<b>AX 1201S</b>	<b>AX 1501S</b>
Ordering codes	<b>1334040</b>	<b>1334041</b>	<b>1334042</b>	<b>1334043</b>	<b>1334044</b>	<b>1334045</b>	<b>1334046</b>	<b>1334047</b>	<b>1334049</b>
Protected height (mm)	160	310	460	610	760	910	1060	1210	1510
Num. of beams	15	30	45	60	75	90	105	120	150
Overall height (mm) *	261	411	561	711	861	1011	1161	1311	1611

#### MASTER/SLAVE Models with 20 - 30 - 50 mm resolution and 2 - 3 beams - Max. range: selectable 6 or 18 m



<b>MASTER Resolution 20 mm</b>	-	<b>AX 302M</b>	<b>AX 452M</b>	<b>AX 602M</b>	<b>AX 752M</b>	<b>AX 902M</b>	<b>AX 1052M</b>	<b>AX 1202M</b>	<b>AX 1502M</b>
Ordering codes	-	<b>1334121</b>	<b>1334122</b>	<b>1334123</b>	<b>1334124</b>	<b>1334125</b>	<b>1334126</b>	<b>1334127</b>	<b>1334129</b>
<b>SLAVE Resolution 20 mm</b>	<b>AX 152S</b>	<b>AX 302S</b>	<b>AX 452S</b>	<b>AX 602S</b>	<b>AX 752S</b>	<b>AX 902S</b>	<b>AX 1052S</b>	<b>AX 1202S</b>	<b>AX 1502S</b>
Ordering codes	<b>1334140</b>	<b>1334141</b>	<b>1334142</b>	<b>1334143</b>	<b>1334144</b>	<b>1334145</b>	<b>1334146</b>	<b>1334147</b>	<b>1334149</b>
Protected height (mm)	160	310	460	610	760	910	1060	1210	1510
Num. of beams	15	30	45	60	75	90	105	120	150
Overall height (mm) *	261	411	561	711	861	1011	1161	1311	1611

<b>MASTER Resolution 30 mm</b>	-	<b>AX 303M</b>	<b>AX 453M</b>	<b>AX 603M</b>	<b>AX 753M</b>	<b>AX 903M</b>	<b>AX 1053M</b>	<b>AX 1203M</b>	<b>AX 1503M</b>
Ordering codes	-	<b>1334221</b>	<b>1334222</b>	<b>1334223</b>	<b>1334224</b>	<b>1334225</b>	<b>1334226</b>	<b>1334227</b>	<b>1334229</b>
<b>SLAVE Resolution 30 mm</b>	<b>AX 153S</b>	<b>AX 303S</b>	<b>AX 453S</b>	<b>AX 603S</b>	<b>AX 753S</b>	<b>AX 903S</b>	<b>AX 1053S</b>	<b>AX 1203S</b>	<b>AX 1503S</b>
Ordering codes	<b>1334240</b>	<b>1334241</b>	<b>1334242</b>	<b>1334243</b>	<b>1334244</b>	<b>1334245</b>	<b>1334246</b>	<b>1334247</b>	<b>1334249</b>
Protected height (mm)	160	310	460	610	760	910	1060	1210	1510
Num. of beams	8	16	24	32	40	48	56	64	80
Overall height (mm) *	261	411	561	711	861	1011	1161	1311	1611



<b>MASTER Resolution 50 mm</b>		<b>AX 305M</b>	<b>AX 455M</b>	<b>AX 605M</b>	<b>AX 755M</b>	<b>AX 905M</b>	<b>AX 1055M</b>	<b>AX 1205M</b>	<b>AX 1505M</b>
Ordering codes		<b>1334421</b>	<b>1334422</b>	<b>1334423</b>	<b>1334424</b>	<b>1334425</b>	<b>1334426</b>	<b>1334427</b>	<b>1334429</b>
<b>SLAVE Resolution 50 mm</b>		<b>AX 305S</b>	<b>AX 455S</b>	<b>AX 605S</b>	<b>AX 755S</b>	<b>AX 905S</b>	<b>AX 1055S</b>	<b>AX 1205S</b>	<b>AX 1505S</b>
Ordering codes		<b>1334441</b>	<b>1334442</b>	<b>1334443</b>	<b>1334444</b>	<b>1334445</b>	<b>1334446</b>	<b>1334447</b>	<b>1334449</b>
Protected height (mm)		310	460	610	760	910	1060	1210	1510
Num. of beams		8	12	16	20	24	28	32	40
Overall height (mm) *		411	561	711	861	1011	1161	1311	1611



<b>MASTER 2, 3 beams</b>	<b>AX 2BM</b>	<b>AX 3BM</b>
Ordering codes	<b>1334620</b>	<b>1334621</b>
<b>SLAVE 2, 3 beams</b>	<b>AX 2BS</b>	<b>AX 3BS</b>
Ordering codes	<b>1334640</b>	<b>1334641</b>
Num. of beams	2	3
Beam spacing (mm)	500	400
Protected height (mm)	510	810
Overall height (mm) *	711	1011

\* Overall height is referred to the slave models. In the Master models the total light curtain height is increased by 10 mm due to the presence of the secondary connector.

► "ACCESSORIES" on page 84



# ADMIRAL AX BK

## WITH BLANKING FUNCTION

### MAIN FEATURES

Automatic Start/Restart  
 Two self-testing solid state PNP safety outputs.  
 Max. range: up to 5 m for 14 mm resolution; up to 18 m for other resolution models  
 Built-in floating blanking function with 5 configuration modes.  
 All connections and configurations by means of M12 connectors.  
 Use of unshielded cables up to 100 m.  
 Suppression of optical interference by means of range selection.  
 Master and Slave models for serial connection of 2 light curtains.  
 Maximum length of the connections between Master and Slave: 50 meters, with standard unshielded cable.  
 Start/Restart interlock and EDM via external AD SR1 interface.

### TECHNICAL FEATURES

<b>Safety level</b>	Type 4 according to IEC/TS 61496-2 SIL 3 – SILCL 3 according to IEC 61508 - IEC 62061 PL e – Cat. 4 according to ISO 13849-1
<b>Protected heights (mm)</b>	160 ... 1810
<b>Resolutions (mm)</b>	14, 20, 40, 90
<b>Max. range (m)</b>	selectable 2 or 5 for 14 mm resolution selectable 6 or 18 for 20, 40, 90 mm resolution
<b>Response time (ms)</b>	6 ... 27
<b>Safety outputs</b>	2 PNP auto-controlled – 500 mA at 24 VDC with short-circuit, overload, polarity reversal protection
<b>Signalling</b>	seven-segment display and LEDs for light curtain's status and diagnostic
<b>Start/Restart</b>	automatic
<b>Blanking</b>	floating, selectable
<b>Blanking configurations</b>	5 modes: 1, 2 or 3 beams without compulsory object presence 1 or 2 beams with compulsory object presence
<b>Power supply (VDC)</b>	24 ± 20%
<b>Electrical connections for AX and AX Master</b>	M12 5-pole for emitter M12 8-pole for receiver
<b>Electrical connections between Master and Slave</b>	M12 5-pole for emitter and receiver
<b>Max. cable length (m)</b>	100 (50 between master and slave)
<b>Operating temperature (°C)</b>	0 ... 55
<b>Protection rating</b>	IP 65
<b>Fastening modes</b>	back slot, side slot or to the top and lower end lower end with swivel brackets
<b>Cross section (mm)</b>	35 x 45



Emitter

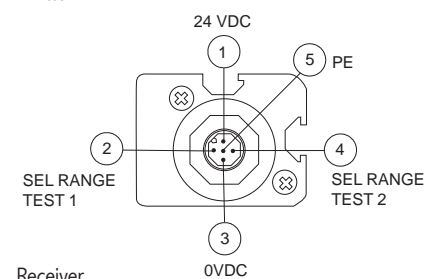

Receiver

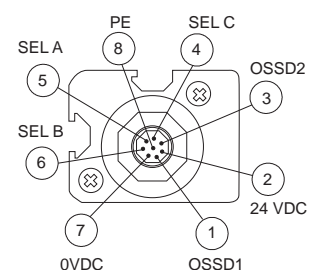

Safety Level
<b>TYPE 4</b>
SIL 3 – SILCL 3 PL e – Cat. 4



### THE BLANKING FUNCTION

Information on the blanking function can be found on page 43 in the Safety Guide section.

The Floating Blanking function is available on the Admiral AX BK models. Floating Blanking allows the detected object to move freely inside the light curtain's protected field, under the condition that the intercepted beams are adjacent and that their number is not higher than the configured one.

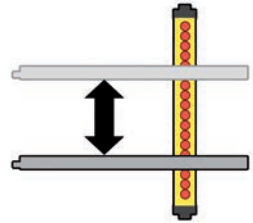

### CONFIGURATION MODES OF THE BLANKING FUNCTION IN THE ADMIRAL AX BK MODELS:

Mode	Type of blanking configuration	N. of beams in blanking	Detection characteristics
A1	1 beam without compulsory object presence	1	1 beam can be obstructed with the light curtain remaining in an ON condition
A2	2 beams without compulsory object presence	2	1 or 2 adjacent beams can be obstructed with the light curtain remaining in an ON condition
A3	3 beams without compulsory object presence	3	1, 2 or 3 adjacent beams can be obstructed with the light curtain remaining in an ON condition
B1	2 beams with compulsory object presence	1/2	at least 1 beam and no more than 2 adjacent beams must be obstructed for the light curtain to remaining in an ON condition
B2	3 beams with compulsory object presence	1/2/3	at least 1 beam and no more than 3 adjacent beams must be obstructed for the light curtain to remaining in an ON condition



### WARNING!

The AX BK light curtains with blanking function do not have the feedback input (EDM); therefore, they cannot be combined with the AD SRO and AD SROA relay modules but they should be connected with the AD SR1 or AD SRM safety interfaces.

The use of the blanking function and the type of configuration selected depend on the characteristics of the application to be protected. You need to verify, based on the risk analysis of your application, whether the use of this function is permitted or not and what configuration it is possible to use. ReeR SpA does not assume responsibility for the improper use of the blanking function and for any consequent damage.

The use of the blanking function may need a recalculation of the safety distance due to the modified detection capability.

# ADMIRAL AX BK

## WITH BLANKING FUNCTION

### Models with 14 mm resolution - Max. range: selectable 2 or 5 m



Resolution 14 mm	AX 151 BK	AX 301 BK	AX 451 BK	AX 601 BK	AX 751 BK	AX 901 BK	AX 1051 BK	AX 1201 BK	AX 1351 BK	AX 1501 BK	AX 1651 BK	AX 1801 BK
Ordering codes	1334060	1334061	1334062	1334063	1334064	1334065	1334066	1334067	1334068	1334069	1334070	1334061
Protected height (mm)	160	310	460	610	760	910	1060	1210	1360	1510	1660	1810
Num. of beams	15	30	45	60	75	90	105	120	135	150	165	180
Overall height (mm)	261	411	561	711	861	1011	1161	1311	1461	1611	1761	1911

### Models with 20 - 40 - 90 mm resolution - Max. range: selectable 6 or 18 m



Resolution 20 mm	AX 152 BK	AX 302 BK	AX 452 BK	AX 602 BK	AX 752 BK	AX 902 BK	AX 1052 BK	AX 1202 BK	AX 1352 BK	AX 1502 BK	AX 1652 BK	AX 1802 BK
Ordering codes	1334160	1334161	1334162	1334163	1334164	1334165	1334166	1334167	1334168	1334169	1334170	1334171
Protected height (mm)	160	310	460	610	760	910	1060	1210	1360	1510	1660	1810
Num. of beams	15	30	45	60	75	90	105	120	135	150	165	180
Overall height (mm)	261	411	561	711	861	1011	1161	1311	1461	1611	1761	1911



Resolution 40 mm	AX 304 BK	AX 454 BK	AX 604 BK	AX 754 BK	AX 904 BK	AX 1054 BK	AX 1204 BK	AX 1354 BK	AX 1504 BK	AX 1654 BK	AX 1804 BK
Ordering codes	1334361	1334362	1334363	1334364	1334365	1334366	1334367	1334368	1334369	1334370	1334371
Protected height (mm)	310	460	610	760	910	1060	1210	1360	1510	1660	1810
Num. of beams	10	15	20	25	30	35	40	45	50	55	60
Overall height (mm)	411	561	711	861	1011	1161	1311	1461	1611	1761	1911



Resolution 90 mm	AX 609 BK	AX 759 BK	AX 909 BK	AX 1059 BK	AX 1209 BK	AX 1359 BK	AX 1509 BK	AX 1659 BK	AX 1809 BK
Ordering codes	1334563	1334564	1334565	1334566	1334567	1334568	1334569	1334570	1334571
Protected height (mm)	610	760	910	1060	1210	1360	1510	1660	1810
Num. of beams	9	11	13	15	17	19	21	23	25
Overall height (mm)	711	861	1011	1161	1311	1461	1611	1761	1911

### MASTER MODELS WITH BLANKING



Resolution 14 mm	AX 301 BKM	AX 451 BKM	AX 601 BKM	AX 751 BKM	AX 901 BKM	AX 1051 BKM	AX 1201 BKM	AX 1501 BKM
Ordering codes	1334081	1334082	1334083	1334084	1334085	1334086	1334088	1334089
Protected height (mm)	310	460	610	760	910	1060	1210	1510
Num. of beams	30	45	60	75	90	105	120	150
Overall height (mm)	421	571	721	871	1021	1171	1321	1671



Resolution 20 mm	AX 302 BKM	AX 452 BKM	AX 602 BKM	AX 752 BKM	AX 902 BKM	AX 1052 BKM	AX 1202 BKM	AX 1502 BKM
Ordering codes	1334181	1334182	1334183	1334184	1334185	1334186	1334187	1334189
Protected height (mm)	310	460	610	760	910	1060	1210	1510
Num. of beams	30	45	60	75	90	105	120	150
Overall height (mm)	421	571	721	871	1021	1171	1321	1671

- The Master with Blanking models are combined with the Slave models of the Admiral series AX.
- The blanking function is only present on the Master models with resolution 14 and 20 mm.

► "ACCESSORIES" on page 84

### ADDITIONAL ARMS FOR L MUTING - ACCESSORY FOR ADMIRAL AND VISION

#### MAIN FEATURES

The 2 SLA additional arms with built-in muting crossed beams photoelectric sensors, combined with the ADMIRAL or VISION (page 145) light curtains series form a one way access control system with L logic (exit only).

Can be mounted on ADMIRAL or VISION light curtains of any height and resolution.

The muting function is realized by using an external module: MOSAIC or AD SRM, on which must be connected light curtains and the sensors of the arms.

**Installation note:** on the light curtain receiver must be mounted the arm transmitter and vice versa.

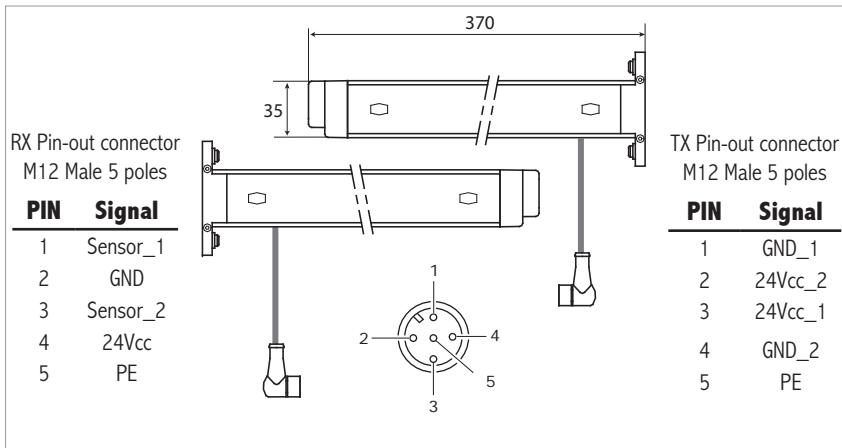

#### TECHNICAL FEATURES

MODEL	SLA
Ordering codes	1330920
Built-in sensors	2 crossed beams
Max. range (m)	1 - 2,5

### ADDITIONAL ARMS FOR T MUTING - ACCESSORY FOR ADMIRAL AND VISION

#### MAIN FEATURES

The 4 SLA additional arms with built-in muting crossed beams photoelectric sensors, combined with the ADMIRAL or VISION (page 145) light curtains series form a bi-directional access control system with T logic (entry and exit).

Can be mounted on ADMIRAL or VISION light curtains of any height and resolution.

The muting function is realized by using an external module: MOSAIC or AD SRM, on which must be connected light curtains and the sensors of the arms.

**Installation note:** on the light curtain receiver must be mounted the arm transmitter and vice versa.

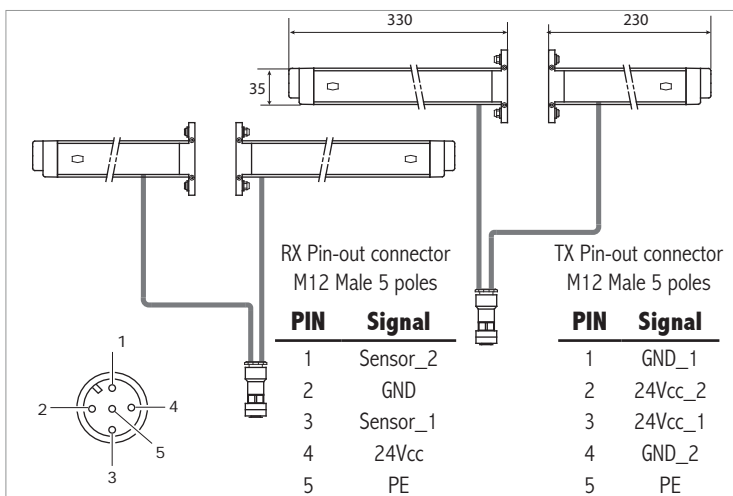

#### TECHNICAL FEATURES

MODELS	STA
Ordering codes	1330921
Built-in sensors	2 crossed beams
Max. range (m)	1 - 2,5

## ADMIRAL

### ORDERING INFORMATION

#### Each Admiral light curtain comprises:

Emitter and Receiver pair	CD-ROM containing the multi-language instruction manual complete with CE declaration of conformity
Brackets and inserts	Quick installation guide

### ACCESSORIES

#### For Admiral light curtains the following accessories, to be ordered separately, are available:

AD SR Safety relays	▶ See page 183
FMC floor mounting columns	▶ See page 220
SP deflection mirrors	▶ See page 223
LAD laser alignment device	▶ See page 224
SAV vibrations dampers	▶ See page 225
SFB swivel fixing brackets	▶ See page 226
Connectors	▶ See list hereunder:

#### CONNECTORS FOR ADMIRAL (AD emitter and receiver / AX - AX BK emitter)

Model	Code	Description
CD 5	1330950	M12 straight connector 5 poles pre-wired, cable 5 m
CD 10	1330956	M12 straight connector 5 poles pre-wired, cable 10 m
CD 15	1330952	M12 straight connector 5 poles pre-wired, cable 15 m
CD 20	1330957	M12 straight connector 5 poles pre-wired, cable 20 m
CD 25	1330949	M12 straight connector 5 poles pre-wired, cable 25 m
CD 50	1330965	M12 straight connector 5 poles pre-wired, cable 50 m
CD 95	1330951	M12 90° angle connector 5 poles pre-wired, cable 5 m
CD 910	1330958	M12 90° angle connector 5 poles pre-wired, cable 10 m
CD 915	1330953	M12 90° angle connector 5 poles pre-wired, cable 15 m
CDM 9	1330954	M12 straight connector 5 poles with screw terminal, PG9 cable gland
CDM 99	1330955	M12 90° angle connector, 5 poles with screw terminal, PG9 cable gland

#### CONNECTORS FOR ADMIRAL AX and AX BK receiver

Model	Code	Description
C8D 5	1330980	M12 straight connector 8 poles pre-wired, cable 5 m
C8D 10	1330981	M12 straight connector 8 poles pre-wired, cable 10 m
C8D 15	1330982	M12 straight connector 8 poles pre-wired, cable 15 m
C8D 25	1330967	M12 straight connector 8 poles pre-wired, cable 25 m
C8D 40	1440966	M12 straight connector 8 poles pre-wired, cable 40 m
C8D 95	1330983	M12 90° angle connector 8 poles pre-wired, cable 5 m
C8D 910	1330984	M12 90° angle connector 8 poles pre-wired, cable 10 m
C8D 915	1330985	M12 90° angle connector 8 poles pre-wired, cable 15 m
C8DM 11	1330978	M12 straight connector 8 poles with screw terminal, PG9/11 cable gland
C8DM 911	1330979	M12 90° angle connector 8 poles with screw terminal, PG9/11 cable gland

#### CONNECTION BETWEEN MASTER AND SLAVE

Model	Code	Description
CDS 03	1330990	0,3 m pre-wired cable with 2 straight connectors M12 5-pole
CIBE 3	1360960	3 m pre-wired cable with 2 straight connectors M12 5-pole
CIBE 5	1360961	5 m pre-wired cable with 2 straight connectors M12 5-pole
CIBE 10	1360962	10 m pre-wired cable with 2 straight connectors M12 5-pole
CIBE 25	1360963	25 m pre-wired cable with 2 straight connectors M12 5-pole

### DIMENSIONS (mm)

#### STANDARD AND SLAVE MODELS

#### MASTER MODELS

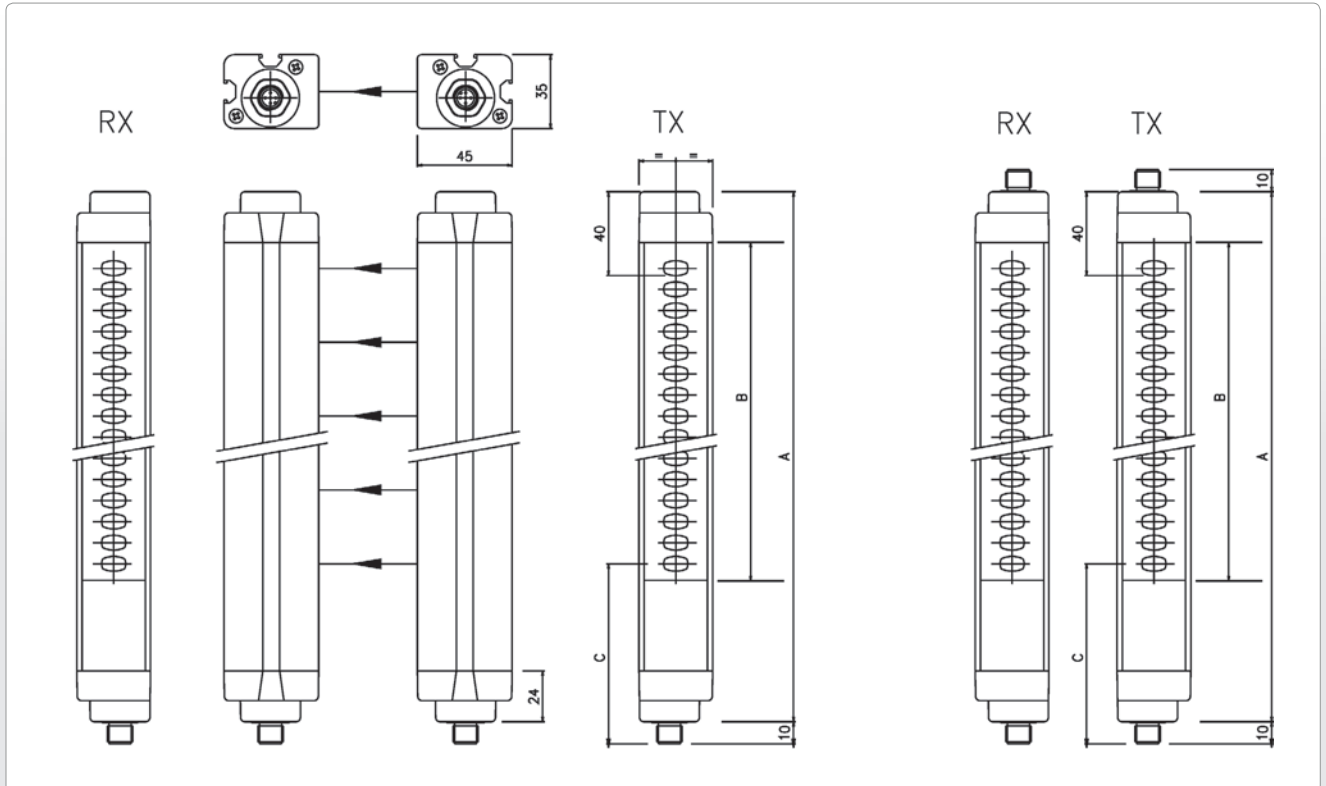

Models	150	300	450	600	750	900	1050	1200	1350	1500	1650	1800
A	251	401	551	701	851	1001	1151	1301	1451	1601	1751	1901
B (protected Height)	160	310	460	610	760	910	1060	1210	1360	1510	1660	1810
C	85											
Mounting	Complete set of 4 LS type brackets included in the package							Complete set of 6 LS type brackets included in the package				

Models	2B	3B	4B
A	701	1001	1101
B (protected Height)	510 *	810 *	910 *
C	135		
Mounting	Complete set of 4 LS type brackets included in the package		

\* for these models the protected height is only indicative and is calculated based on the beams spacing.



### WARNING!

When the light curtain works in the presence of strong vibrations (presses, weaving machines etc.), in order to avoid damages to the light curtain it is necessary to use the vibration dampers SAV (available as accessories)  
 When long range protections or perimeter protections employing mirrors have to be realised it is advisable to use the LAD laser pointer as an alignment aid, as well as the adjustable swivel fastening brackets SFB.



# JANUS





## JANUS

The Janus type 4 family of safety light curtains is the ideal solution for the protection of a vast number of high-risk industrial applications, in particular those requiring a high level of integration of the safety functions.

For example, in the models with built-in Muting function, Janus guarantees the independence of the light curtain from the control circuits of the system (often distant from the protected gate) and, where necessary, also the integration of the Muting sensors.

### The features of the Janus range include:

- Settings of each function integrally performed via the main connector. No need of configuration via software.
- Integration of the main safety functions, including self-testing of the solid state outputs, external device monitoring (EDM) and the Start/Restart interlock function.
- Integration of the Muting function for the MI models and of the Muting sensors for the ML and MT models.
- The utmost reliability in the field, thanks to the rugged construction and to the high level of immunity to external interference (optical, EMC, etc.).

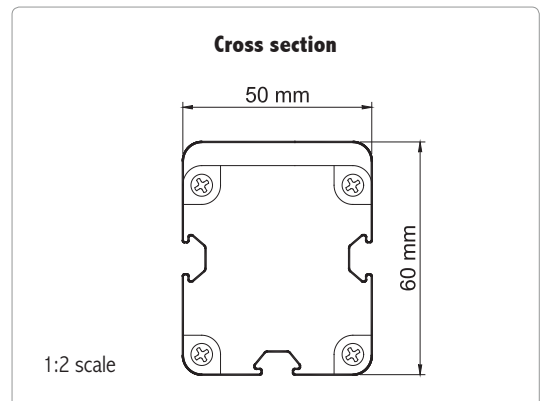
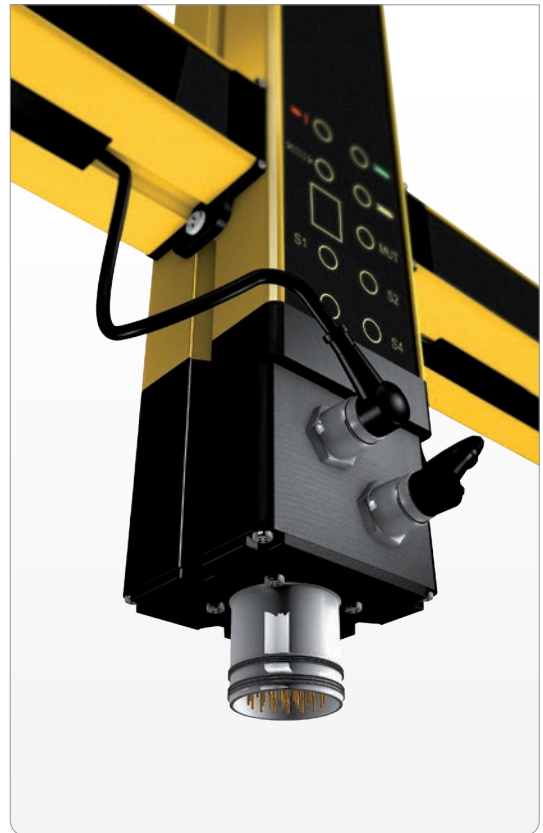



### Safety level: **Type 4 – SIL 3 – SILCL 3 – PL e – Cat. 4**

- 2006/42/CE "Machinery Directive"
- 2004/108/CE "Electromagnetic Compatibility (EMC)"
- 2006/95/CE "Low Voltage Directive (LVD)"
- IEC/EN 61496-1 Ed. 2.1, IEC/TS 61496-2 Ed. 2 "Safety of machinery - Electro-sensitive protective equipment - General requirements and tests"
- EN ISO 13849-1 "Safety of machinery – Safety-related parts of control systems – Part 1: General principles for design"
- IEC/EN 62061 "Safety of machinery – Functional safety of safety-related electrical, electronic and programmable electronic control systems"
- IEC 61508 "Functional safety of electrical/electronic/programmable electronic safety-related systems"
- IEC/TS 62046 Ed. 2 "Safety of machinery – Application of protective equipment to detect the presence of persons"
- UL (C+US) mark for USA and Canada
- ANSI / UL 1998 "Safety Software in Programmable Components".



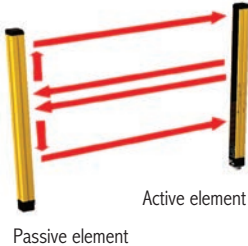

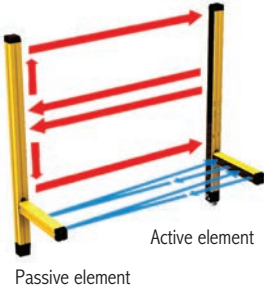
### THE JANUS RANGE

<b>JANUS M</b> Built-in Muting Function		<p><b>MI SERIES</b></p> <p>The MI series features dedicated connections for connecting external Muting sensors of any type such as photocells, proximity sensors, limit switches, etc.; it can manage the Muting function in both two-way and one-way mode.</p> <p>A wide range of models with protected height from 310 mm to 1810 mm with resolution of 30, 40, 90 mm and models with 2, 3, 4 beams provides the solution to any application problem.</p>	<p><b>JANUS MI</b> Range: selectable 6 or 16 m</p>	
		<p><b>JANUS MI TRX and TRXL SERIES</b></p> <p>Janus MI TRX and MI TRXL is composed of an active element and of a passive retro-reflector element requiring no wiring.</p> <p>It features dedicated connections for connecting external muting sensors of any type such as photocells, proximity sensors, limit switches, etc. The MI series can manage the muting function in both two-way and one-way mode.</p> <p>Models with 2, 3, 4 beams provide the solution to any application problem in access control.</p>	<p><b>JANUS MI Long Range</b> Range: selectable 30 or 60 m</p>	<p><b>JANUS MI TRX</b> 2 or 4 external sensors</p>
		<p><b>JANUS ML SERIES</b></p> <p>The ML series, with 2 or 3 beams for body detection, uses an original system of horizontal arms (one for the emitter and one for the receiver) with built-in pre-wired and pre-aligned photoelectric Muting sensors which do not require any adjustment.</p> <p>The arms can be adjusted in height in order to create a detection plane that is more or less angled, with the purpose to achieve correct and constant detection of the material in transit and therefore reliable operation of the protection system.</p> <p>This ensures the maximum speed and simplicity of installation. The ML series manages the Muting function in one-way mode and is particularly suitable for protecting the outfeed gates of palletizing systems.</p>	<p><b>JANUS ML</b> Built-in muting sensors with crossed beams</p> <p>► <a href="#">See page 92</a></p>	<p><b>JANUS ML S2</b> Special models for the correct detection of transparent object. Built-in muting sensors with parallel beams</p> <p>► <a href="#">See page 92</a></p>
		<p><b>JANUS ML TRX, ML TRX G and ML TRX V SERIES</b></p> <p>Also this series uses an original system of horizontal arms (one for the emitter and one for the receiver) with built-in, pre-wired and pre-aligned, photoelectric muting sensors which do not require any adjustment.</p> <p>Both the light grid and the sensor arms are composed of an active, emitter/receiver element and of a passive, retro-reflector element, requiring no wiring.</p> <p>The ML TRX series manages the muting function in one-way mode and is particularly suitable for protecting the outfeed gates of palletizing systems.</p>	<p><b>JANUS ML TRX</b></p>	<p><b>JANUS ML TRX G</b> (Glass models) with special built-in Muting sensors to optimise correct and consistent detection of glass and transparent materials in general.</p>
				<p><b>JANUS ML TRX V</b> Models with longer built-in muting arms available for high-speed conveyors.</p>

CONTINUE

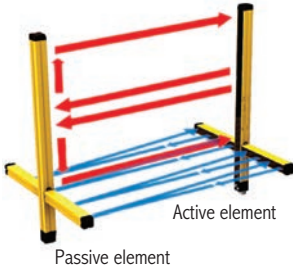
# JANUS

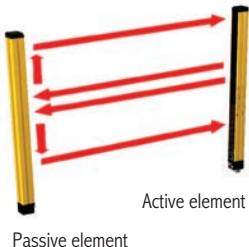
<b>JANUS M</b> Built-in Muting Function		<p><b>JANUS MT SERIES</b></p> <p>The MT series features four horizontal arms (two for the emitter and two for the receiver) with built-in pre-wired and pre-aligned photoelectric Muting sensors that do not require any adjustment.</p> <p>The MT series manages the Muting function in two-way mode for the protection of the infeed/outfeed gates in palletizing systems.</p>	<p><b>JANUS MT</b></p> <p>Built-in muting sensors with crossed beams</p> <p>▶ See page 93</p> <p><b>JANUS MT S4</b></p> <p>The MT series also includes MT S4 special models for the correct detection of transparent objects.</p> <p>Built-in muting sensors with parallel beams</p> <p>▶ See page 93</p>
		<p><b>JANUS MT TRX, MT TRX G and MT TRX V</b></p> <p>Janus MT TRX and MT TRX G features four horizontal arms (two for the emitter and two for the receiver) with built-in pre-wired and pre-aligned photoelectric muting sensors that do not require any adjustment.</p> <p>Both the light grid and the sensor arms are composed of an active, emitter/receiver element and of a passive, retro-reflector element, requiring no wiring.</p> <p>The MT TRX series manages the muting function in two-way mode for the protection of the infeed/outfeed gates in palletizing systems.</p>	<p><b>JANUS MT TRX</b></p> <p><b>JANUS MT TRX G</b> (Glass models) with special built-in Muting sensors to optimise correct and consistent detection of glass and transparent materials in general</p> <p><b>JANUS MT TRX V</b></p> <p>Models with longer built-in muting arms available for high-speed conveyors</p>
<b>JANUS MM TRX</b>		<p><b>JANUS MM TRX</b></p> <p>Janus MM TRX is a modular system with 2, 3 and 4 beams which permits to add pre-wired muting arms in order to get either a ML TRX (one way) or a MT TRX (entry/exit) model with a few simple steps. SL TRX and ST TRX are the pre-wired muting arms and can be ordered separately.</p> <p>Janus MM TRX can also be used with external Muting sensors, with 2 or 4 sensors logic.</p> <p>Muting logics for models MM TRX are:</p> <ul style="list-style-type: none"> <li>• one-way (only exit), together with SL TRX</li> <li>• two-way (entry/exit) together with SL TRX and ST TRX.</li> </ul> <p>Max. range is 6 m (3,5 m if used with SL TRX and ST TRX).</p>	
<b>JANUS J</b> Models, without Muting Function		<p><b>JANUS J</b></p> <p>Models with 2, 3, 4 beams.</p>	<p><b>JANUS J</b></p> <p>Range: selectable 6 or 16 m</p>
		<p><b>JANUS J - Long Range and Long Range M12</b></p> <p>Models with 2, 3, 4 beams and models with 40 mm resolution and protected height from 610 to 1210 mm.</p> <p>Long Range models with 2, 3 and 4 beams are also available in M12 version with a M12 8-pole connector for the receiver.</p>	<p><b>JANUS J - LR, LR M12</b></p> <p>Range: selectable 30 or 60 m</p>
		<p><b>JANUS J LRH M12, J LRH M12 ILP</b></p> <p>Models with 2, 3 and 4 beams Max. range up to 80 meters</p>	<p><b>JANUS J LRH M12</b></p> <p>Range: selectable 40 or 80 m</p>
			<p><b>JANUS J LRH M12 ILP</b></p> <p>With integrated laser pointer</p>
		<p><b>JANUS J TRX, TRXL SERIES</b></p> <p>Janus J TRX and J TRXL are safety light grids with 2, 3, 4 beams consisting of an active element (emitter/receiver) and a retro-reflector passive element which does not require electrical connections.</p> <p>JANUS series J TRX and TRXL are the simplest and quickest installation solutions for detection of a person in access control in hazardous areas, and the ideal solutions for all applications in which it is difficult or costly to cable electrical lines.</p>	<p><b>Janus J TRX</b></p> <p>M12 8-pole connector</p> <p><b>Janus J TRX L</b></p> <p>M23 19-pole connector</p>

### Muting type

#### MI – MI TRX – MI TRXL - MM TRX



#### Two-way Muting with 2 sensors

- Max. time between the 2 Muting activation signals: 4 sec.
- Possibility of use with photocells, proximity sensors, and limit switches.
- Max. Muting time-out time 30 sec. or 90 min. selectable.
- Muting enable input available (TRX models only).

#### Characteristics

- Suitable for the most common pallet infeed/outfeed applications.
- Moreover, the TRX models have also the "Muting enable input" function, which starts the Muting sequence only if necessary for the machine cycle, i.e. Muting enabled only when the conveyor is moving.

#### MI – MI TRX - MM TRX



#### Two-way sequential Muting with 4 sensors

- Max. time between the Muting activation signals: 4 sec. or infinite, selectable.
- Possibility to use with photocells, proximity sensors, and limit switches.
- Max. Muting time-out time 30 sec. or infinite, selectable.
- Muting enable input available (TRX models only).

#### Characteristics

- Correct Muting sequence even in the presence of pallets with reduced width and/or length or not centred with respect to the conveyor.
- Possibility of two-way transit of the pallets and simultaneous protection in the two directions against unauthorised access of personnel.
- Moreover, the TRX models have also the "Muting enable input" function, which starts the Muting sequence only if necessary for the machine cycle, i.e. Muting enabled only when the conveyor is moving.

#### MI – MI TRX - MM TRX



#### One-way Muting with 2 sensors

- Max. time between the 2 Muting activation signals: 4 sec.
- Possibility to use with photocells, proximity sensors, and limit switches.
- Max. Muting time-out time: 30 sec. or 90 min. selectable.

#### Characteristics

- The light curtain only enables the pallet outfeed.
- The Muting function can only be activated from inside the protected zone. No possibility to activate a Muting sequence from the outside.
- Elimination of bulk outside the protected area, as the Muting sensors are only present inside the area.
- Correct Muting sequence even in the presence of a pallet with reduced width and/or length or not centred with respect to the conveyor.
- Moreover, the TRX models have also the "Muting enable input" function, which starts the Muting sequence only if necessary for the machine cycle, i.e. Muting enabled only when the conveyor is moving.

## ML

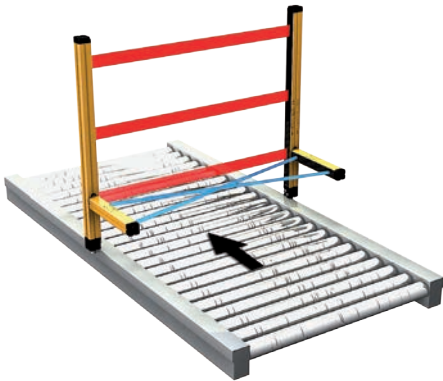

### One-way Muting with 2 sensors 2 Built-in Muting sensors with crossed beams

- Max. time between the 2 Muting activation signals: 4 sec.
- Operating range 1 ... 2.5 metres.
- Muting sensor elements adjustable in height and angle.
- Max. Muting time-out time: 30 sec. or 90 min. selectable.
- Versions with 2 or 3 beams.

#### Characteristics

- Reduced installation time and costs.
- Sensors positioned in compliance with the regulations regarding the geometry of Muting sensors (IEC TS 62046) and all the other safety parameters; this makes it possible to avoid dangers arising from positioning errors and from possible tampering.
- The light curtain only allows pallet outfeed.
- The Muting function can only be activated from inside the protected zone. No possibility to activate a Muting sequence from the outside.
- Elimination of bulk outside the protected area, as the Muting sensors are only present inside the area.
- Correct Muting sequence even in the presence of a pallet with reduced width and/or length or not centred with respect to the conveyor.

## ML S2 - ML TRX - ML TRX G – ML TRX V – MM TRX with SL TRX



### One-way Muting with 2 sensors 2 Built-in Muting sensors with parallel beams

- Max. time between the 2 Muting activation signals: 4 sec.
- Operating range: 0 ... 2 meters for ML S2 and ML TRX G models, 0 ... 3,5 for ML TRX model.
- Muting sensor elements adjustable in height and angle.
- Max. Muting time-out time: 30 sec. or 90 min. selectable.
- Versions with 2 or 3 beams.
- Muting enable input available (TRX models only).

#### Characteristics

- Reduced installation time and costs.
- The light curtain only allows pallet outfeed.
- The Muting function can only be activated from inside the protected zone. No possibility to activate a Muting sequence from the outside.
- Elimination of bulk outside the protected area, as the Muting sensors are only present inside the area.
- Correct Muting sequence even in the presence of a pallet with reduced width and/or length or not centred with respect to the conveyor.
- ML TRX G models especially designed for transparent material, ideal solution for glass and bottling industry.
- ML TRX V models for high-speed conveyors.
- Moreover, the TRX models have also the "Muting enable input" function, which starts the Muting sequence only if necessary for the machine cycle, i.e. Muting enabled only when the conveyor is moving.

### MT

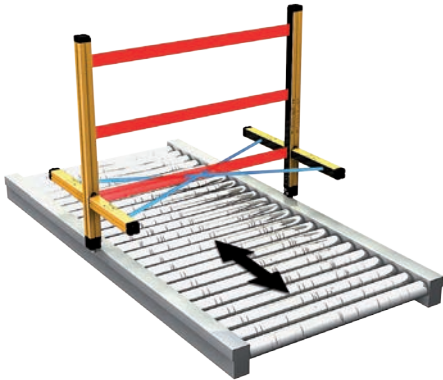

#### Two-way Muting with 2 sensors 2 Built-in Muting sensors with crossed beams

- Max. time between the 2 Muting activation signals: 4 sec.
- Operating range: 1 ... 2.5 metres.
- Muting sensor elements adjustable in height and angle.
- Max. Muting time-out time: 30 sec. or 90 min. selectable.
- Versions with 2 or 3 beams.

#### Characteristics

- Reduced installation time and costs.
- Standard solution for the most common pallet infeed/outfeed applications.

### MT S4 – MT TRX – MT TRX G – MT TRX V – MM TRX with SL TRX and ST TRX



#### Two-way sequential Muting with 4 sensors 4 Built-in Muting sensors with parallel beam

- Max. time between the Muting activation signals: 4 sec. or infinite, selectable.
- Operating range: 0 ... 2 meters for MT S4. and 0 ... 3.5 meters for MT TRX models.
- Muting sensor elements adjustable in height and angle.
- Max. Muting time-out time: 30 sec. or infinite, selectable.
- Versions with 2 or 3 beams.

#### Characteristics

- Correct Muting sequence even in the presence of a pallet with reduced width and/or length or not centred with respect to the conveyor.
- Possibility of two-way transit of the pallets and simultaneous protection in the two directions against unauthorized access of personnel.
- MT TRX G models especially designed for transparent material, ideal solution for glass and bottling industry.
- MT TRX V models for High-speed conveyors.
- Moreover, the TRX models have also the "Muting enable input" function, which starts the Muting sequence only if necessary for the machine cycle, i.e. Muting enabled only when the conveyor is moving.

# JANUS M

## WITH MUTING FUNCTION

### MAIN FEATURES

Built-in Muting function in all the models.

Ideal for palletizer applications.

MI models with front M12 connectors for external Muting sensors, with operating logic with 2 or 4 sensors.

Patented ML and MT models with Muting sensors built into pre-wired and pre-aligned arms, adjustable in height and angle.

ML: pallet outfeed only. MT: pallet infeed and outfeed.

Broad flexibility of configuration for the Muting time-outs; two types of override selectable. Configuration is carried out via hardware by means of the main connector.

Use of unshielded cables up to 100 m.

MI Long Range models available with range up to 60 m for hand protection with resolution 40 mm and body detection with 2, 3, 4 beams.

MJB Connection Box for quick connection of the light curtains and providing the main commands necessary for their operation close to the protected gate.



### Solutions Table

#### "L" Logic Crossed beams



Suitable solution for any applications of pallet exit.

#### "L" Logic Parallel beams



Suitable solution for transparent material: glass and bottling industry of pallet exit.

#### "T" Logic Crossed beams



Suitable solution for the most common pallet infeed/outfeed applications. Ideal solution in case of a continuous flow of pallets even without separation between the pallets.

#### "T" Logic Parallel beams

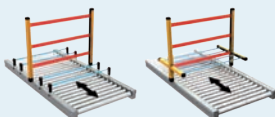

Suitable solution for transparent material and application with presence of a pallet with reduced width or not centred with respect to the conveyor. Through the verification of the 4 sensors, allows to set infinite muting time-out.

Please note: this configuration needs a separation between two consecutive pallets equal to the distance between the two external muting sensors.

**Models ML and MT are quick and easy to install. Also, they are complying with regulatory requirements on Muting sensor geometry and all other safety-related parameters, as per IEC TS 62046 and other current standards.**



Safety Level:

# TYPE 4

SIL 3 – SILCL 3  
PL e – Cat. 4

### GENERAL TECHNICAL DATA

<b>Safety level</b>	Type 4 according to IEC/TS 61496-2 SIL 3 – SILCL 3 according to IEC 61508 - IEC 62061 PL e – Cat. 4 according to ISO 13849-1
<b>Response time (ms)</b>	7 ... 30
<b>Safety outputs</b>	2 PNP auto-controlled - 500 mA at 24 VDC with short-circuit, overload, polarity reversal protection
<b>Light curtain status indication and weak signal output</b>	PNP - 100 mA at 24 VDC
<b>Signalling</b>	7-segment display and LEDs for self-diagnosis and light curtain status
<b>Muting lamp output (mandatory)</b>	24 VDC; 0,5 ... 5 W
<b>Start/Restart</b>	selectable automatic or manual
<b>External Device Monitoring</b>	external device monitoring feedback input with enabling, selectable
<b>Max. Muting time-out</b>	30 sec. or 90 min. selectable (30 sec. or infinite selectable only for MT S4 and MI models with 4 sensors logic)
<b>Override function</b>	built-in override function with 2 operating modes, selectable: - manual action with hold to run - automatic with pulse command
<b>Max. Override Time-out (min.)</b>	15
<b>Power supply (VDC)</b>	24 ± 20%
<b>Electrical connections MI-ML-MT models</b>	emitter M12 5-pole - receiver: M23 19-pole - Muting sensors: M12 5-pole
<b>Max. length electrical connections (m)</b>	100
<b>Operating temperature (°C)</b>	-10 ... 55
<b>Protection rating</b>	IP 65
<b>Cross-section dimensions (mm)</b>	50 x 60
<b>MI SERIES</b>	
<b>Protected heights (mm)</b>	310 ... 1810 for light curtains with 40 and 90 mm resolution 310 ... 1210 for light curtains with 30 mm resolution
<b>Resolutions available (mm)</b>	30, 40, 90
<b>Number of beams for access control</b>	2, 3, 4
<b>Max. range (m)</b>	selectable 6 or 16
<b>Max. range for Long Range models (m)</b>	selectable 30 or 60
<b>Muting logic</b>	two-way with 2 or 4 sensors one-way with 2 sensors
<b>Muting Sensors</b>	external Muting sensors with relay or PNP output (dark-on logic)
<b>ML SERIES</b>	
<b>Number of beams for access control</b>	2, 3
<b>Operating range (m)</b>	1 ... 2,5 (0 ... 2 for ML S2)
<b>Muting logic</b>	one-way with 2 sensors
<b>Muting Sensors</b>	optoelectronics with 2 crossed or parallel beams built-in – pre-aligned – pre-wired, with adjustable height and angle
<b>MT SERIES</b>	
<b>Number of beams for access control</b>	2, 3
<b>Operating range (m)</b>	1 ... 2,5 (0 ... 2 for MT S4)
<b>Muting logic</b>	two-way with 2 sensors (models MT) two-way sequential with 4 sensors (models MT S4)
<b>Muting Sensors</b>	optoelectronics with 2 crossed or 4 parallel beams built-in – pre-aligned – pre-wired, with adjustable height and angle



# JANUS M

WITH MUTING FUNCTION



<b>MI e MI LR</b> <b>2, 3, 4 beams</b>	<b>MI</b> <b>2B</b>	<b>MI</b> <b>3B</b>	<b>MI</b> <b>4B</b>	<b>MI</b> <b>2B LR</b>	<b>MI</b> <b>3B LR</b>	<b>MI</b> <b>4B LR</b>
Ordering codes	<b>1360660</b>	<b>1360661</b>	<b>1360662</b>	<b>1360670</b>	<b>1360671</b>	<b>1360672</b>
Number of beams	2	3	4	2	3	4
Beam spacing (mm)	500	400	300	500	400	300
Protected height (mm)	510	810	910	510	810	910
Overall height (mm)	776	1076	1176	776	1076	1176
Max. range (m)	selectable 6 or 16			selectable 30 or 60		

<b>ML</b> <b>2, 3 beams</b>	<b>ML</b> <b>2B</b>	<b>ML</b> <b>3B</b>	<b>ML</b> <b>2B S2</b>	<b>ML</b> <b>3B S2</b>	<b>MT</b> <b>2, 3 beams</b>	<b>MT</b> <b>2B</b>	<b>MT</b> <b>3B</b>	<b>MT</b> <b>2B S4</b>	<b>MT</b> <b>3B S4</b>
Ordering codes	<b>1360020</b>	<b>1360021</b>	<b>1360024</b>	<b>1360025</b>	Ordering codes	<b>1360030</b>	<b>1360031</b>	<b>1360034</b>	<b>1360035</b>
Number of beams	2	3	2	3	Number of beams	2	3	2	3
Beam spacing (mm)	500	400	500	400	Beam spacing (mm)	500	400	500	400
Protected height (mm)	510	810	510	810	Protected heights (mm)	510	810	510	810
Overall height (mm)	776	1076	776	1076	Overall height (mm)	776	1076	776	1076
Muting sensors	2 crossed beams		2 parallel beams		Muting sensors	2 crossed beams		4 parallel beams	
Operating range (m)	1 ... 2,5		0 ... 2		Operating range (m)	1 ... 2,5		0 ... 2	

<b>MI</b> <b>Resolution 30 mm</b>	<b>MI</b> <b>303</b>	<b>MI</b> <b>453</b>	<b>MI</b> <b>603</b>	<b>MI</b> <b>753</b>	<b>MI</b> <b>903</b>	<b>MI</b> <b>1053</b>	<b>MI</b> <b>1203</b>
Ordering codes	<b>1360241</b>	<b>1360242</b>	<b>1360243</b>	<b>1360244</b>	<b>1360245</b>	<b>1360246</b>	<b>1360247</b>
Protected height (mm)	310	460	610	760	910	1060	1210
Number of beams	16	24	32	40	48	56	64
Overall height (mm)	476	626	776	926	1076	1226	1376
Max. range (m)	selectable 6 or 16						



<b>MI</b> <b>Resolution 40 mm</b>	<b>MI</b> <b>304</b>	<b>MI</b> <b>454</b>	<b>MI</b> <b>604</b>	<b>MI</b> <b>754</b>	<b>MI</b> <b>904</b>	<b>MI</b> <b>1054</b>	<b>MI</b> <b>1204</b>	<b>MI</b> <b>1354</b>	<b>MI</b> <b>1504</b>	<b>MI</b> <b>1654</b>	<b>MI</b> <b>1804</b>
Ordering codes	<b>1360375</b>	<b>1360376</b>	<b>1360377</b>	<b>1360378</b>	<b>1360379</b>	<b>1360380</b>	<b>1360381</b>	<b>1360382</b>	<b>1360383</b>	<b>1360384</b>	<b>1360385</b>
Protected height (mm)	310	460	610	760	910	1060	1210	1360	1510	1660	1810
Number of beams	10	15	20	25	30	35	40	45	50	55	60
Overall height (mm)	476	626	776	926	1076	1226	1376	1526	1676	1826	1976
Max. range (m)	selectable 6 – 16										

<b>MI Long Range</b> <b>Resolution 40 mm</b>	<b>MI</b> <b>604 LR</b>	<b>MI</b> <b>904 LR</b>	<b>MI</b> <b>1204 LR</b>
Ordering codes	<b>1360388</b>	<b>1360390</b>	<b>1360392</b>
Protected height (mm)	610	910	1210
Number of beams	30	45	60
Overall height (mm)	776	1076	1376
Max. range (m)	selectable 30 or 60		

<b>Model MI</b> <b>Resolution 90 mm</b>	<b>MI</b> <b>309</b>	<b>MI</b> <b>459</b>	<b>MI</b> <b>609</b>	<b>MI</b> <b>759</b>	<b>MI</b> <b>909</b>	<b>MI</b> <b>1059</b>	<b>MI</b> <b>1209</b>	<b>MI</b> <b>1359</b>	<b>MI</b> <b>1509</b>	<b>MI</b> <b>1659</b>	<b>MI</b> <b>1809</b>
Ordering codes	<b>1360541</b>	<b>1360542</b>	<b>1360543</b>	<b>1360544</b>	<b>1360545</b>	<b>1360546</b>	<b>1360547</b>	<b>1360548</b>	<b>1360549</b>	<b>1360550</b>	<b>1360551</b>
Protected height (mm)	310	460	610	760	910	1060	1210	1360	1510	1660	1810
Number of beams	5	7	9	11	13	15	17	19	21	23	25
Overall height (mm)	476	626	776	926	1076	1226	1376	1526	1676	1826	1976
Max. range (m)	selectable 6 or 16										

► "ACCESSORIES" on page 113

#### MAIN FEATURES

Built-in Muting function in all the models. Ideal for palletizer applications.

Models with passive retro-reflector element, MI TRX with front M12 connectors for external Muting sensors and operating logic with 2 or 4 sensors.

Models MI TRXL with single M23 connector and operating logic with 2 sensors.

Patented ML TRX and MT TRX models with passive retro-reflector elements and reflex Muting sensors built into pre-wired and pre-aligned arms, adjustable in height and angle.

Models ML TRX G e MT TRX G (Glass) with special built-in Muting sensors to optimise correct and consistent detection of glass and transparent materials in general.

Models ML TRX V e MT TRX V with longer built-in muting arms available for high-speed conveyors.

Note: ML TRX: pallet outfeed only. MT TRX: pallet infeed and outfeed.

MM TRX models with two, three and four beams with modular system which permits to add pre-wired muting arms so that the light grid can be used either as one-way (ML TRX) or as entry/exit (MT TRX) system with a few simple steps. MM TRX can also be used with external Muting sensors, with 2 or 4 sensors logic.

Broad flexibility of configuration for the Muting time-outs; two types of override selectable.

Input Muting enable and Muting state output available.

Configuration is carried out via hardware by means of the main connector.

Unshielded cables up to 100 m long are used.

MJB Connection Box for quick connection of the light curtains and providing the main commands necessary for their operation close to the protected gate.

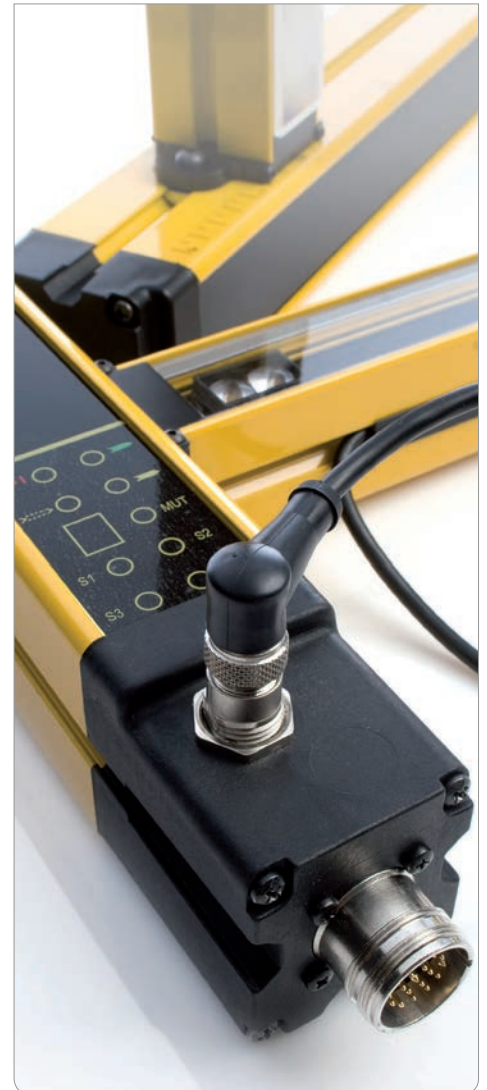

**JANUS ML TRX**

**ML TRX and MT TRX models are quick and easy to install. Also, they are complying with regulatory requirements on Muting sensor geometry and all other safety-related parameters, as per IEC TS 62046 and other current standards.**

Safety Level:

**TYPE 4**

SIL 3 – SILCL 3  
PL e – Cat. 4



# JANUS M TRX

## WITH MUTING FUNCTIONS AND PASSIVE RETRO-REFLECTOR ELEMENT

### GENERAL TECHNICAL DATA

<b>Safety level</b>	Type 4 according to IEC/TS 61496-2 SIL 3 – SILCL 3 according to IEC 61508 - IEC 62061 PL e – Cat. 4 according to ISO 13849-1
<b>Response time (ms)</b>	≤ 7
<b>Safety outputs</b>	2 PNP - 500 mA at 24 VDC with short-circuit, overload, polarity reversal protection
<b>Light curtain status indication and weak signal output</b>	PNP - 100 mA at 24 VDC
<b>Muting status indication output</b>	PNP - 100 mA at 24 VDC
<b>Muting lamp output</b>	24 VDC; 0,5 ... 5 W
<b>Muting enable input</b>	0 or 24 VDC (Active Low)
<b>Signalling</b>	7-segment display and LEDs for self-diagnosis and light curtain status
<b>Start/Restart</b>	automatic or manual restart selectable
<b>External Device Monitoring</b>	external device monitoring feedback input with enabling, selectable
<b>Max. muting time-out</b>	30 sec. or 90 min. selectable and (30 sec. or infinite selectable only MT TRX and MI TRX models with 4 sensors logic)
<b>Override function</b>	built-in override function with 2 operating modes, selectable: manual action with hold to run / automatic with pulse command
<b>Max. Override Time-out (min.)</b>	15
<b>Power supply (VDC)</b>	24 ± 20%
<b>Electrical connections MI TRX – ML TRX - MT TRX models</b>	main connector: M23 19-pole - muting sensors: M12 5-pole
<b>Electrical connections MI TRXL</b>	unique connector: M23 19-pole
<b>Max. length electrical connections (m)</b>	100
<b>Operating temperature (°C)</b>	-10 ... 55
<b>Protection rating</b>	IP 65
<b>Cross-section dimensions (mm)</b>	50 x 60
<b>MI TRX / MI TRXL SERIES</b>	
<b>Number of beams</b>	2, 3, 4
<b>Max. range (m)</b>	6
<b>Muting Logic</b>	two-way with 2 or 4 sensors and one-way with 2 sensors two-way with 2 sensors
<b>Muting Sensors</b>	external muting sensors with relay or PNP output (dark-on logic)
<b>MM TRX SERIES</b>	
<b>Number of beams</b>	2, 3, 4
<b>Max. range (m)</b>	6 (3,5 when fitted with SL TRX and ST TRX)
<b>Muting Logic</b>	two-way with 2 or 4 external sensors and one-way with 2 external sensors
<b>Muting Sensors</b>	external muting sensors with relay or PNP output (dark-on logic). Reflex optoelectronics with 2 parallel beams Built-in - pre-aligned - pre-wired, with adjustable height and angle. Reflex optoelectronics with 4 parallel beams Built-in - pre-aligned - pre-wired, with adjustable height and angle.
<b>ML TRX / ML TRX G / ML TRX V SERIES</b>	
<b>Number of beams</b>	2, 3
<b>Operating range ML TRX, ML TRX V (m)</b>	0 ... 3,5
<b>Operating range ML TRX G (m)</b>	0 ... 2
<b>Muting Logic</b>	one-way with 2 sensors
<b>Muting Sensors</b>	reflex optoelectronics with 2 parallel beams built-in - pre-aligned - pre-wired, with adjustable height and angle

<b>MT TRX / MT TRX G / MT TRX V SERIES</b>	
<b>Number of beams</b>	2, 3
<b>Operating range MT TRX, MT TRX V (m)</b>	0 ... 3,5
<b>Operating range MT TRX G (m)</b>	0 ... 2
<b>Muting logic</b>	two-way sequential with 4 sensors
<b>Muting Sensors</b>	reflex optoelectronics with 4 parallel beams built-in - pre-aligned - pre-wired, with adjustable height and angle



<b>MI TRX – MI TRXL 2, 3, 4 beams</b>	<b>MI 2B TRX</b>	<b>MI 3B TRX</b>	<b>MI 4B TRX</b>	<b>MI 2B TRXL</b>	<b>MI 3B TRXL</b>	<b>MI 4B TRXL</b>
Ordering codes	<b>1360680</b>	<b>1360682</b>	<b>1360684</b>	<b>1360681</b>	<b>1360683</b>	<b>1360685</b>
Number of beams	2	3	4	2	3	4
Beam spacing (mm)	500	400	300	500	400	300
Protected height (mm)	510	810	910	510	810	910
Overall height (mm)	776	1076	1176	741	1041	1141
Max. range (m)	6					

<b>MM TRX 2, 3, 4 beams</b>	<b>MM 2B TRX</b>	<b>MM 3B TRX</b>	<b>MM 4B TRX</b>
Ordering codes	<b>1360690</b>	<b>1360691</b>	<b>1360692</b>
Number of beams	2	3	4
Beam spacing (mm)	500	400	300
Protected height (mm)	510	810	910
Overall height (mm)	776	1076	1176
Operating range (m)	6 (3,5 when fitted with SL TRX and ST TRX)		

<b>ML TRX – ML TRX G 2, 3 beams</b>	<b>ML 2B TRX</b>	<b>ML 2B TRX G</b>	<b>ML 3B TRX</b>	<b>ML 3B TRX G</b>
Ordering codes	<b>1360040</b>	<b>1360042</b>	<b>1360041</b>	<b>1360043</b>
<b>ML TRX V 2, 3 beams</b>	<b>ML 2B TRX V</b>	-	<b>ML 3B TRX V</b>	-
Ordering codes	<b>1360044</b>	-	<b>1360045</b>	-
Number of beams	2		3	
Beam spacing (mm)	500		400	
Protected height (mm)	510		810	
Overall height (mm)	776		1076	
Muting sensors	2 parallel beams	2 parallel beams (transparent material)	2 parallel beams	2 parallel beams (transparent material)
Operating range (m)	0 ... 3,5	0 ... 2	0 ... 3,5	0 ... 2

<b>MT TRX – MT TRX G 2, 3 beams</b>	<b>MT 2B TRX</b>	<b>MT 2B TRX G</b>	<b>MT 3B TRX</b>	<b>MT 3B TRX G</b>
Ordering codes	<b>1360050</b>	<b>1360052</b>	<b>1360051</b>	<b>1360053</b>
<b>MT TRX V 2, 3 beams</b>	<b>MT 2B TRX V</b>	-	<b>MT 3B TRX V</b>	-
Ordering codes	<b>1360054</b>	-	<b>1360055</b>	-
Number of beams	2		3	
Beam spacing (mm)	500		400	
Protected height (mm)	510		810	
Overall height (mm)	776		1076	
Muting sensors	4 parallel beams	4 parallel beams (transparent material)	4 parallel beams	4 parallel beams (transparent material)
Operating range (m)	0 ... 3,5	0 ... 2	0 ... 3,5	0 ... 2

► "ACCESSORIES" on page 113

## JANUS M - JANUS M TRX

### SENSOR ELEMENT ADJUSTMENT - ML and MT versions

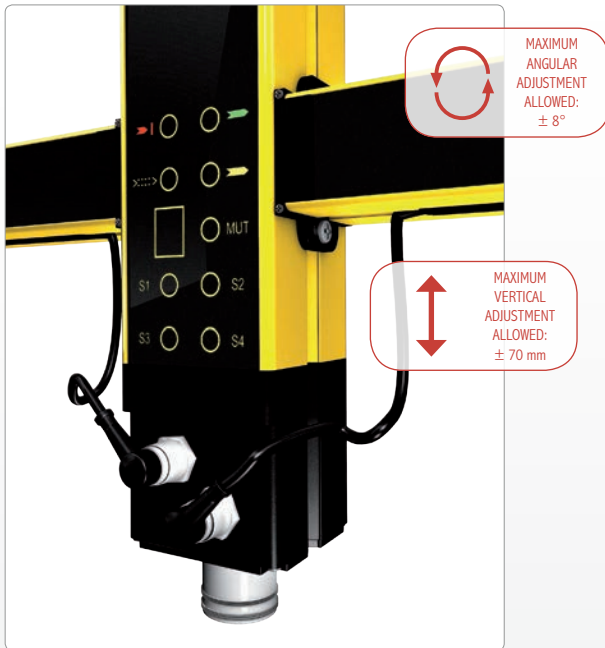

The sensor elements present in all Janus ML and MT versions are adjustable in height and angle.

This important and unique feature enables the inclination of the detection plane of the sensors to obtain correct and constant detection of irregular materials in transit.

Models ML TRX G e MT TRX G (Glass) with special built-in Muting sensors to optimise correct and consistent detection of glass and transparent materials in general.

### Example of application of Janus ML TRX light curtain for protection of palletizer outfeed zone

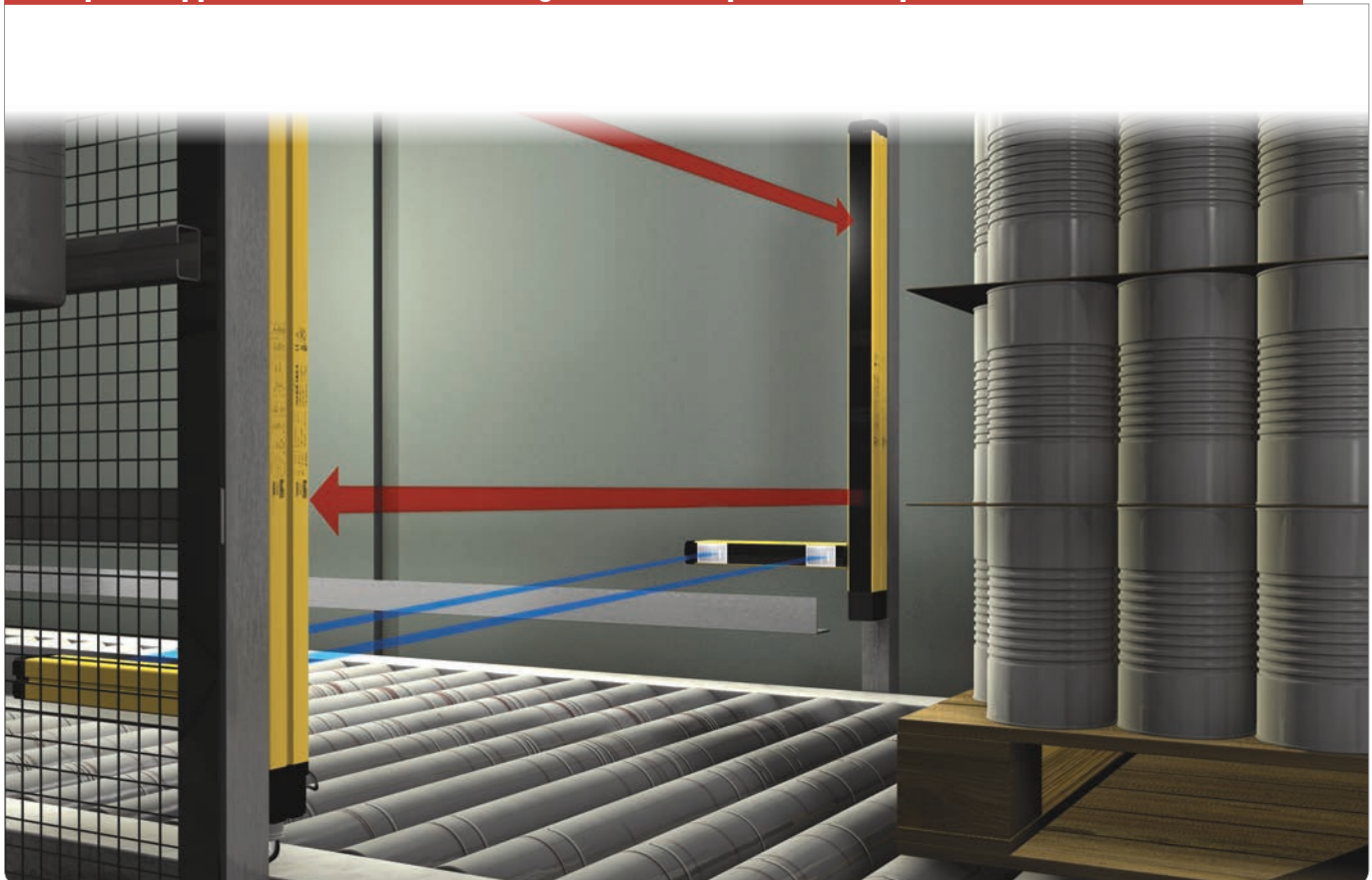

#### MAIN FEATURES

Two self-testing solid state PNP safety outputs.  
 Built-in Start/Restart interlock, selectable.  
 Feedback input for control of external relays (EDM).  
 All configuration via hardware by means of main connector.  
 Use of unshielded cables up to 100 m long.

J Long Range models available, with range up to 60 m, for access control with 2, 3, 4 beams or with resolution 40 mm, also ideal for perimeter protection with the use of deflection mirrors.

Floor mounting columns FMC available.

MJ Box for quick connection of the light curtains and availability of the Restart command in the area of the protected gate

#### Janus J LRH M12 and J LRH M12 ILP models

Models with 2, 3 and 4 beams Max. range up to 80 meters use a M12 5-pole connector for the emitter and a M12 8-pole connector for the receiver.

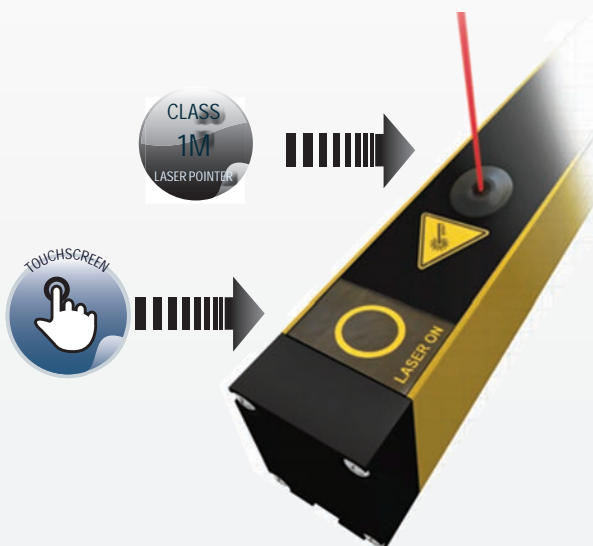
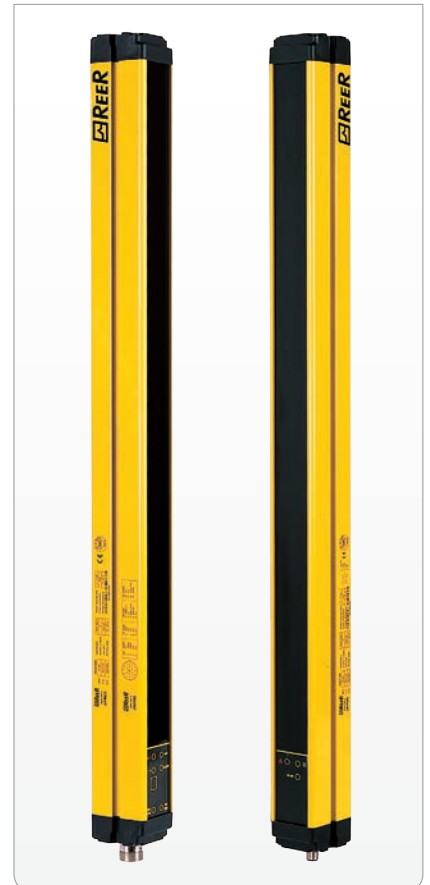

Also available with integrated laser pointer (**J LRH M12 ILP**).

The laser used is a Class 1M according to the EN 60825-1: not dangerous to the eyes and skin.  
 One laser pointer per beams.

Safety Level:

# TYPE 4

**SIL 3 – SILCL 3**  
**PL e – Cat. 4**



#### TECHNICAL FEATURES

<b>Safety level</b>	Type 4 according to IEC/TS 61496-2 SIL 3 – SILCL 3 according to IEC 61508 - IEC 62061 PL e – Cat. 4 according to ISO 13849-1
<b>Protected heights (mm)</b>	510 ... 1210
<b>Resolutions (mm)</b>	40 (long range only)
<b>Number of beams for body detection in access control</b>	2, 3, 4
<b>Max. range (m)</b>	selectable 6 or 16 selectable 30 or 60 for long range models selectable 40 or 80 for extra long range models
<b>Response time (ms)</b>	7 ... 28,5
<b>Safety outputs</b>	2 PNP - 500 mA at 24 VDC with short-circuit, overload, polarity reversal protection
<b>Light curtain status indication and weak signal output</b>	PNP - 100 mA at 24 VDC
<b>Signalling</b>	seven-segment display and LEDs for light curtain's status and diagnostic

## JANUS J

### WITH BUILT-IN CONTROL FUNCTIONS

<b>Start/Restart</b>	automatic or manual restart selectable
<b>External Device Monitoring</b>	external device monitoring feedback input with enabling, selectable
<b>Power supply (VDC)</b>	24 ± 20%
<b>Electrical connections</b>	M12 5-pole for emitter and M23 19-pole for receiver M12 5-pole for emitter - M12 8-pole for receiver for J ... M12 models
<b>Max. cable length (m)</b>	100
<b>Operating temperature (°C)</b>	-10 ... 55
<b>Protection rating</b>	IP 65
<b>Cross section (mm)</b>	50 x 60
<b>Laser pointer Max. power (mW)</b>	<1 (class 1M according to the EN 60825-1)



<b>J</b> <b>2, 3, 4 beams</b>	<b>J 2B</b>	<b>J 3B</b>	<b>J 4B</b>
Ordering codes	<b>1360640</b>	<b>1360641</b>	<b>1360642</b>
Number of beams	2	3	4
Beam spacing (mm)	500	400	300
Protected height (mm)	510	810	910
Overall height (mm)	741	1041	1141
Max. range (m)	selectable 6 or 16		



<b>J Long Range</b> <b>2, 3, 4 beams</b>	<b>J 2B LR</b>	<b>J 3B LR</b>	<b>J 4B LR</b>
Ordering codes	<b>1360630</b>	<b>1360631</b>	<b>1360632</b>
<b>J Long Range M12</b> <b>2, 3, 4 beams</b>	<b>J 2B LR M12</b>	<b>J 3B LR M12</b>	<b>J 4B LR M12</b>
Ordering codes	<b>1360634</b>	<b>1360635</b>	<b>1360636</b>
Number of beams	2	3	4
Beam spacing (mm)	500	400	300
Protected height (mm)	510	810	910
Overall height (mm)	741 - 736 (J ... M12 models)	1041 - 1036 (J ... M12 models)	1141 - 1136 (J ... M12 models)
Max. range (m)	selectable 30 or 60		



<b>J LRH M12</b> <b>2, 3, 4 beams</b>	<b>J 2B LRH M12</b>	<b>J 3B LRH M12</b>	<b>J 4B LRH M12</b>
Ordering codes	<b>1360637</b>	<b>1360638</b>	<b>1360639</b>
<b>J LRH M12 ILP</b> <b>2, 3, 4 beams</b>	<b>J 2B LRH M12 ILP</b>	<b>J 3B LRH M12 ILP</b>	<b>J 4B LRH M12 ILP</b>
Ordering codes	<b>1360646</b>	<b>1360647</b>	<b>1360648</b>
Number of beams	2	3	4
Beam spacing (mm)	500	400	300
Protected height (mm)	510	810	910
Overall height (mm)	736	1036	1136
Max. range (m)	selectable 40 or 80		



<b>J Long Range</b> <b>Resolution 40 mm</b>	<b>J 604 LR</b>	<b>J 904 LR</b>	<b>J 1204 LR</b>
Ordering codes	<b>1360363</b>	<b>1360365</b>	<b>1360367</b>
Protected height (mm)	610	910	1210
Number of beams	30	45	60
Overall height (mm)	741	1041	1341
Max. range (m)	selectable 30 or 60		

► "ACCESSORIES" on page 113

## JANUS J TRX - J TRX L

WITH BUILT-IN CONTROL FUNCTIONS AND PASSIVE RETRO-REFLECTOR ELEMENT

### MAIN FEATURES

- Passive retro-reflector element.
- Two self-testing solid state PNP safety outputs.
- Built-in Start/Restart interlock, selectable.
- Feedback input for control of external relays (EDM).
- All configuration via hardware by means of main connector. No need of configuration via software.
- Use of unshielded cables up to 100 m long.
- Electrical connection by means M12, 8-pole connectors for J TRX model and M23, 19-pole for J TRXL model.
- MJ Box for quick connection of the light curtains and availability of the Restart command in the area of the protected gate (only for model J TRX L).
- Janus J TRX and J TRXL are safety light grids with 2, 3, 4 beams consisting of an active element (emitter/receiver) and a retro-reflector passive element which does not require electrical connections.
- JANUS series J TRX and TRXL are the simplest and quickest installation solutions for detection of a person in access control in hazardous areas, and the ideal solutions for all applications in which it is difficult or costly to cable electrical lines.

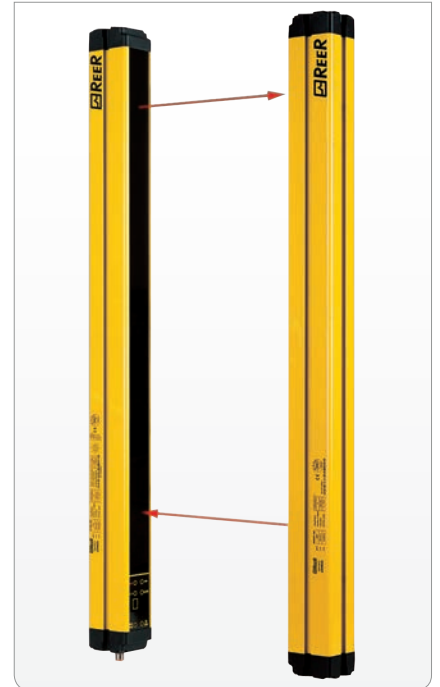

### TECHNICAL FEATURES

<b>Safety level</b>	Type 4 according to IEC/TS 61496-2 SIL 3 – SILCL 3 according to IEC 61508 - IEC 62061 PL e – Cat. 4 according to ISO 13849-1
<b>Number of beams for body detection in access control</b>	2, 3, 4
<b>Max. range (m)</b>	6
<b>Response time (ms)</b>	≤ 7
<b>Safety outputs</b>	2 PNP auto-controlled - 500 mA at 24 VDC with short-circuit, overload, polarity reversal protection
<b>Signalling</b>	seven-segment display and LEDs for light curtain's status and diagnostic
<b>Start/Restart</b>	automatic or manual, selectable
<b>External Device Monitoring</b>	external device monitoring feedback input with enabling selectable
<b>Power supply (VDC)</b>	24 ± 20%
<b>Electrical connections</b>	M23 19-pole – J TRXL models M12 8-pole – J TRX model
<b>Max. cable length (m)</b>	100
<b>Operating temperature (°C)</b>	-10 ... 55
<b>Protection rating</b>	IP 65
<b>Cross section (mm)</b>	50 x 60

Safety level:

# TYPE 4

SIL 3 – SILCL 3  
PL e – Cat. 4





## JANUS J TRX - J TRX L

WITH BUILT-IN CONTROL FUNCTIONS AND PASSIVE RETRO-REFLECTOR ELEMENT



<b>J TRX / J TRXL 2, 3, 4 beams</b>	<b>J 2B TRX</b>	<b>J 3B TRX</b>	<b>J 4B TRX</b>	<b>J 2B TRXL</b>	<b>J 3B TRXL</b>	<b>J 4B TRXL</b>
Ordering codes	<b>1360650</b>	<b>1360656</b>	<b>1360655</b>	<b>1360651</b>	<b>1360652</b>	<b>1360653</b>
Number of beams	2	3	4	2	3	4
Beam spacing (mm)	500	400	300	500	400	300
Protected height (mm)	510	810	910	510	810	910
Overall height (mm)	736	1041	1141	741	1041	1141
Connector	M12 8-pole	M12 8-pole	M12 8-pole	M23 19-pole	M23 19-pole	M23 19-pole
Max. range (m)	6					

► "ACCESSORIES" on page 113

Connection boxes Janus MJB are accessory devices designed for quick, reliable connection of Janus light grids and to ensure that major operating controls needed for operation are available in the guarded area.

#### MAIN FEATURES

- Lighted button for light curtain Start/Restart with green LED for indicating output status and weak signal
- Key selector controlling the override function
- Indicator lamp for Muting function active
- Connector for connection to the light curtain
- Dip switches for configuration of light curtain functions
- 2 Built-in safety relay with guided contacts driven and controlled by the light curtain
- Internal terminal blocks for cable connections
- Selector for connection of external Muting lamp
- Selector for internal or external relay control
- Electrical connection through cable gland
- Versions without Start/Restart and Override commands for connection with Janus J light curtain without Muting.



Complying with:

- 2004/108/EC "Electromagnetic Compatibility (EMC)"
- 2006/95/EC "Low Voltage Directive (LVD)"
- UL (C+US) mark for USA and Canada.

#### TECHNICAL FEATURES

MODELS	MJB 1	MJB 2	MJB 3	MJB 4
<b>Ordering codes</b>	1360930	1360931	1360932	1360933
<b>Override command</b>	yes	no	yes	no
<b>Built-in Muting lamp</b>	yes	no	yes	no
<b>Safety relay output</b>	Relay - 2 contact NO 2A - 250 VAC		Relay - 2 contact NO + 1 NC * 2A - 250 VAC	
<b>Connectors</b>	M23 19-pole for receiver / light curtain connection M12 5-pole for emitter / light curtain connection (not used with TRX light curtains)			
<b>Start/Restart button</b>	yes			
<b>Dimensions - h x w x d (mm)</b>	110 x 180 x 110			

\* In MJB 3 and MJB 4 boxes each NO safety output line is interrupted twice by the two relays.

MJB 1 - MJB 3



MJB 2 - MJB 4



All MJB connection boxes can work with any kind of Janus light curtain (with or without Muting)

## JANUS SL TRX e ST TRX

### ACCESSORY MUTING SENSOR ELEMENTS FOR JANUS MM

#### MAIN FEATURES

Janus SL TRX muting arm, with active and passive retro-reflector elements, in combination with Janus MM TRX models form a one-way access control system with L logic (only exit).

Together with Janus SL TRX and ST TRX muting arms, Janus MM TRX models become a two-way access control system with T logic (entry/exit).

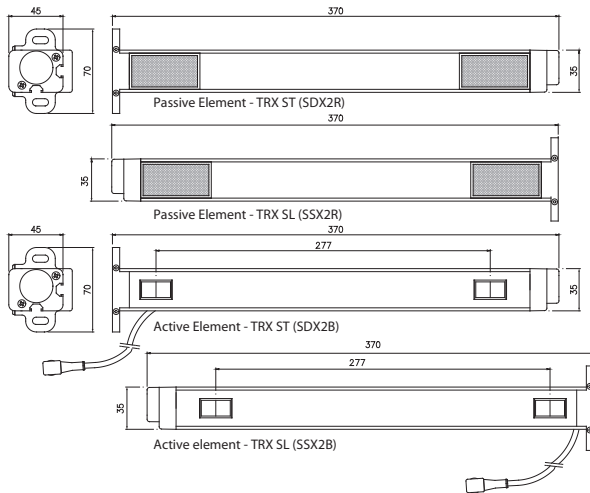

#### TECHNICAL FEATURES

MODELS	SL TRX	ST TRX
<b>Ordering Codes</b>	<b>1360695</b>	<b>1360696</b>
<b>Optoelectronics sensors</b>	2 parallel beams	2 parallel beams
<b>Operating range (m)</b>	0 ... 3,5	0 ... 3,5

Note for ordering

- To form a L logic system you need:  
Light curtain JANUS MM TRX + SL TRX
- To form a T logic system you need:  
Light curtain JANUS MM TRX + SL TRX + ST TRX

## JANUS SL

### ACCESSORY MUTING SENSOR ELEMENTS FOR JANUS MI

#### MAIN FEATURES

The SL series accessory Muting sensor elements (arms) can be combined with the Janus MI light curtain model, making it possible to create an "L" barrier with built-in sensors with 30, 40, 90 mm resolution and protected height from 310 to 1810 mm.

The SL and S2L models have 2 built-in sensors, pre-wired and pre-aligned, with crossed or parallel beams.

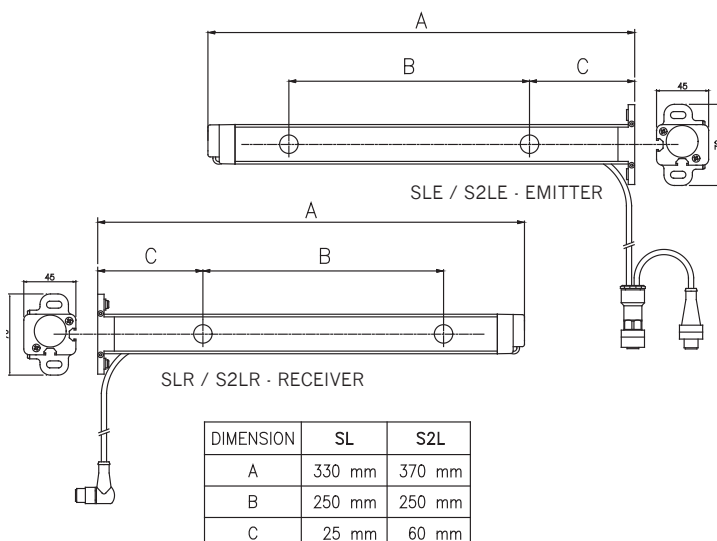

#### TECHNICAL FEATURES

MODELS	SL	S2L
<b>Ordering Codes</b>	<b>1360060</b>	<b>1360061</b>
<b>Optoelectronics sensors</b>	2 crossed beams	2 crossed beams
<b>Operating range (m)</b>	1 ... 2,5	0 ... 2

### DIMENSIONS (mm)

J Models									
DIMENSION	16 m range			Long Range					
	2B	3B	4B	600	900	1200	2B	3B	4B
A (TX-RX)	736	1036	1136	736	1036	1336	736	1036	1136
B (Protected height)	510*	810*	910*	610	910	1210	510*	810*	910*
C (1 <sup>st</sup> beam position)	120			76					

MI Models																			
DIMENSION	16 m range												Long Range						
	300	450	600	750	900	1050	1200	1350	1500	1650	1800	2B	3B	4B	2B	3B	4B		
A (TX)	436	586	736	886	1036	1186	1336	1486	1636	1786	1936	736	1036	1136	736	1036	1136		
A (RX)	476	626	776	926	1076	1226	1376	1526	1676	1826	1976	776	1076	1176	776	1076	1176		
B (Protected height)	310	460	610	760	910	1060	1210	1360	1510	1660	1810	510*	810*	910*	510*	810*	910*		
C (1 <sup>st</sup> beam position)	72												120			76			

ML, MT Models		
DIMENSION	2B	3B
A (TX-RX)	776	1076
C (1 <sup>st</sup> beam position)	120	

\* for these models the protected height is only indicative and is calculated based on the beams spacing.

### JANUS MI

#### Mounting:

Models with  $A < 1050$  - Complete set of 4 LL type brackets included in the package.

Models con  $A \geq 1050$  - Complete set of 6 LL type brackets included in the package.

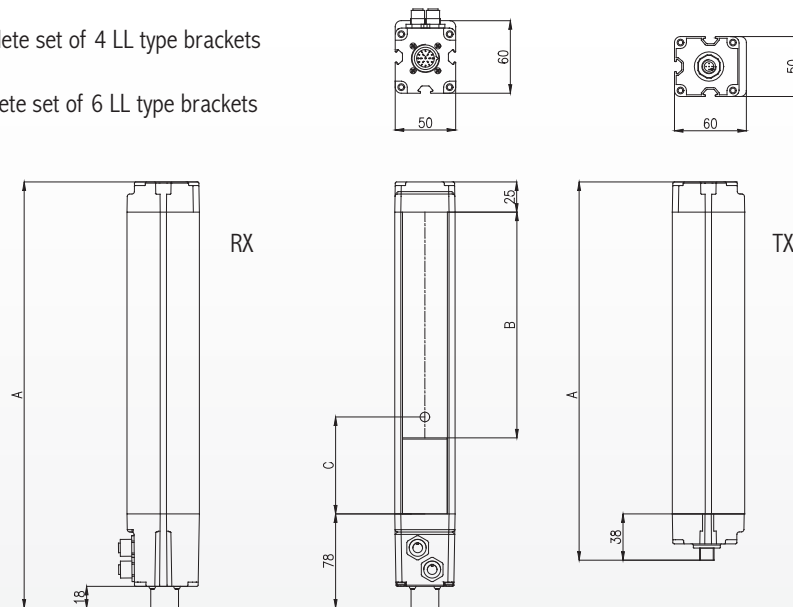

C: Position of the 1<sup>st</sup> active beam

# JANUS

## JANUS ML

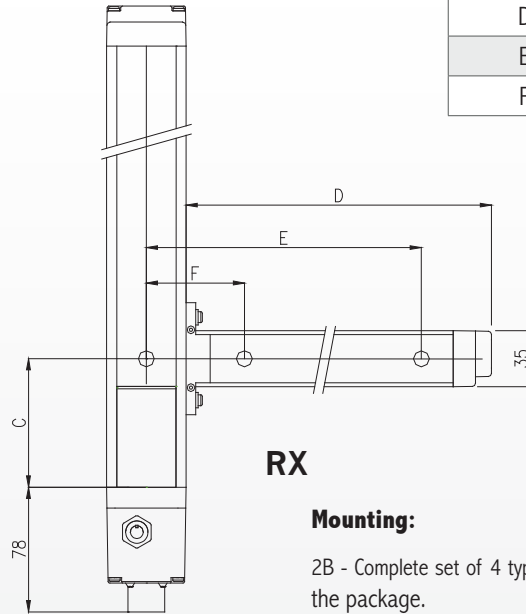
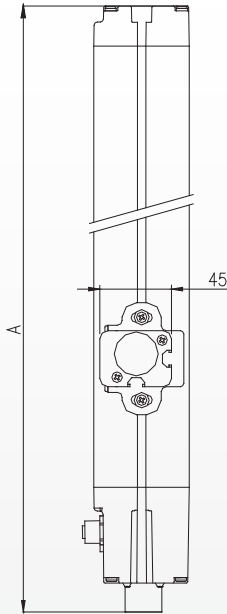

DIMENSIONS	ML
D	330
E	300
F	50

**RX**

**Mounting:**

2B - Complete set of 4 type LL brackets included in the package.

3B - Complete set of 6 type LL brackets included in the package.

## JANUS MT

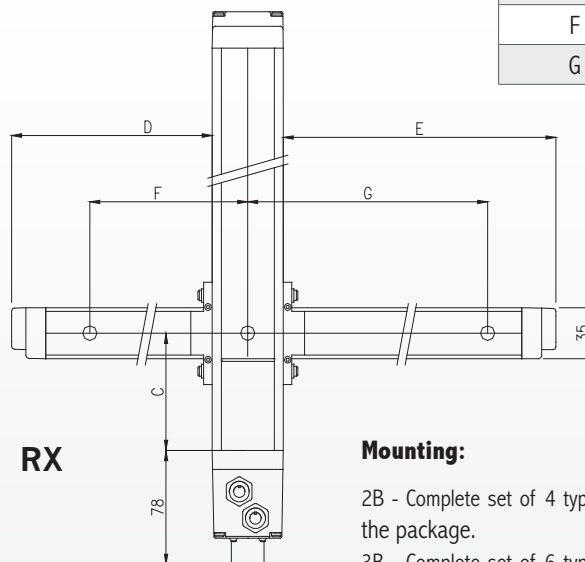
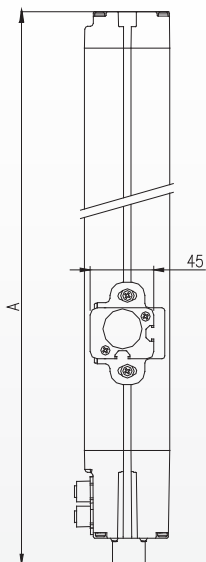

DIMENSIONS	MT
D	230
E	330
F	200
G	300

**RX**

**Mounting:**

2B - Complete set of 4 type LL brackets included in the package.

3B - Complete set of 6 type LL brackets included in the package.

### JANUS "ML S2" - "MT S4"

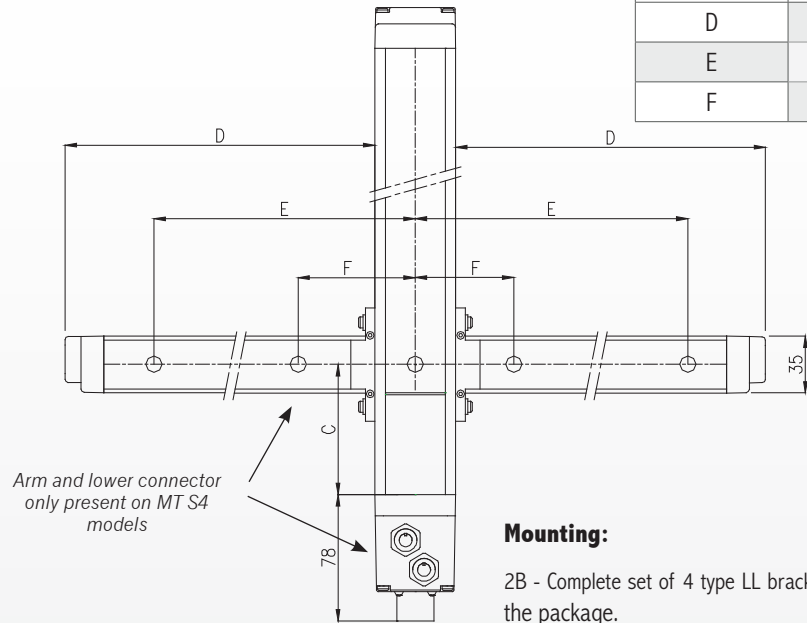
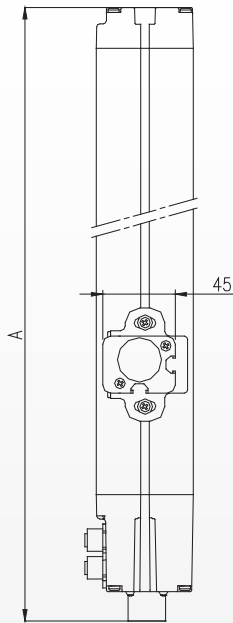

DIMENSIONS	ML S2 / MT S4
D	370
E	334
F	84

Arm and lower connector only present on MT S4 models

#### Mounting:

2B - Complete set of 4 type LL brackets included in the package.

3B - Complete set of 6 type LL brackets included in the package.

### JANUS MI TRX – MI TRX L

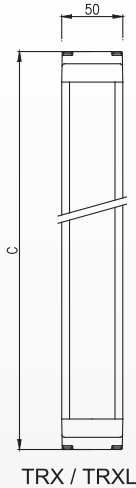
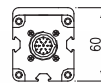
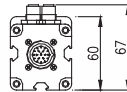
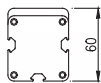

**Passive Element**

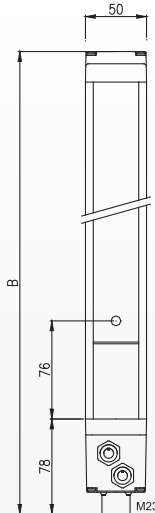

**MI TRX Active Element**

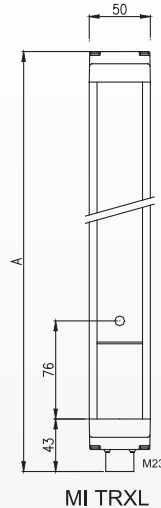

**Active Element**

DIMENSIONS	2B	3B	4B
A	741	1041	1141
B	776	1076	1176
C	723	1023	1123

#### Mounting:

2B, 3B, 4B - Complete set of 2 type LH brackets included in the package.

## JANUS J TRX – J TRXL

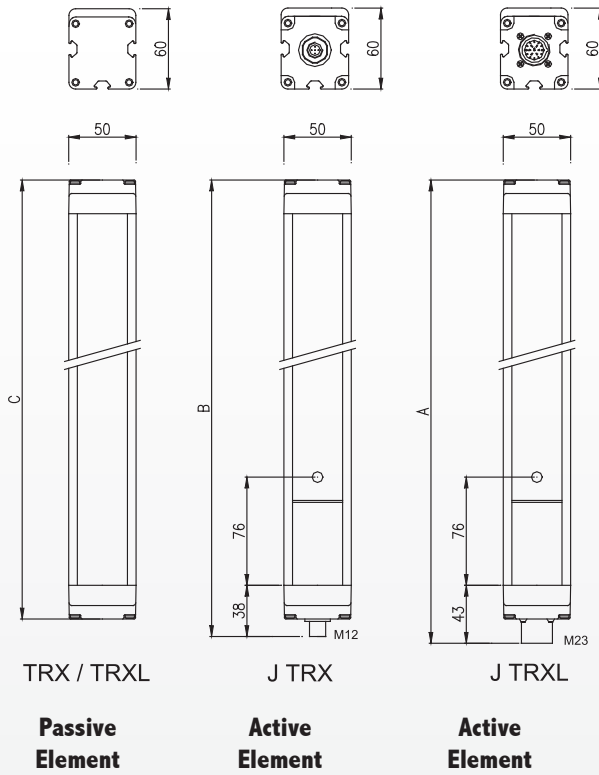

DIMENSIONS	2B	3B	4B
A	741	1041	1141
B	736	1036	1136
C	723	1023	1123

**Mounting:**

2B, 3B, 4B - Complete set of 2 type LH brackets included in the package

## JANUS ML TRX – ML TRX G

**Mounting:**

2B - Complete set of 4 type LL brackets included in the package.  
 3B - Complete set of 6 type LL brackets included in the package.

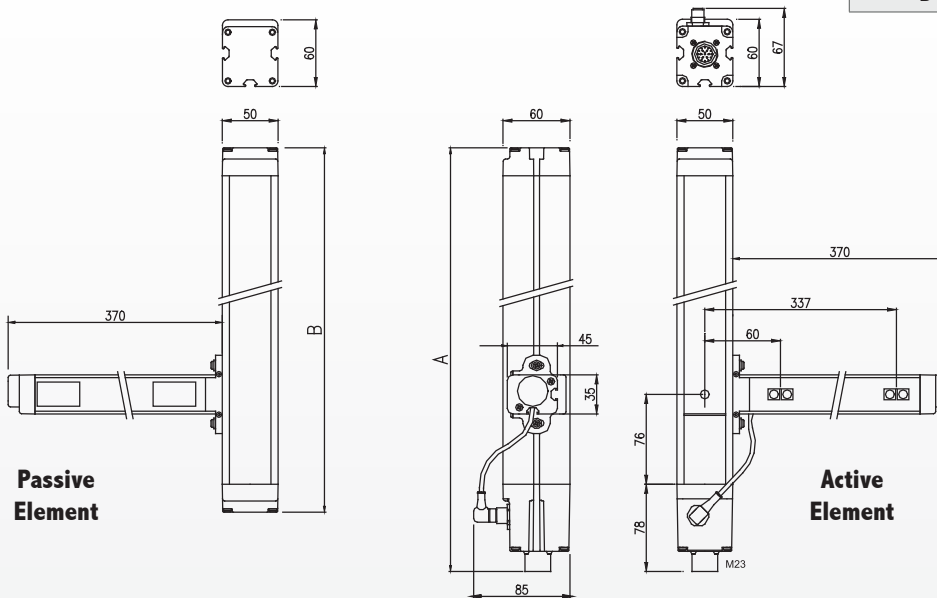

DIMENSIONS	2B	3B
A	776	1076
B	723	1023

### JANUS ML TRX V

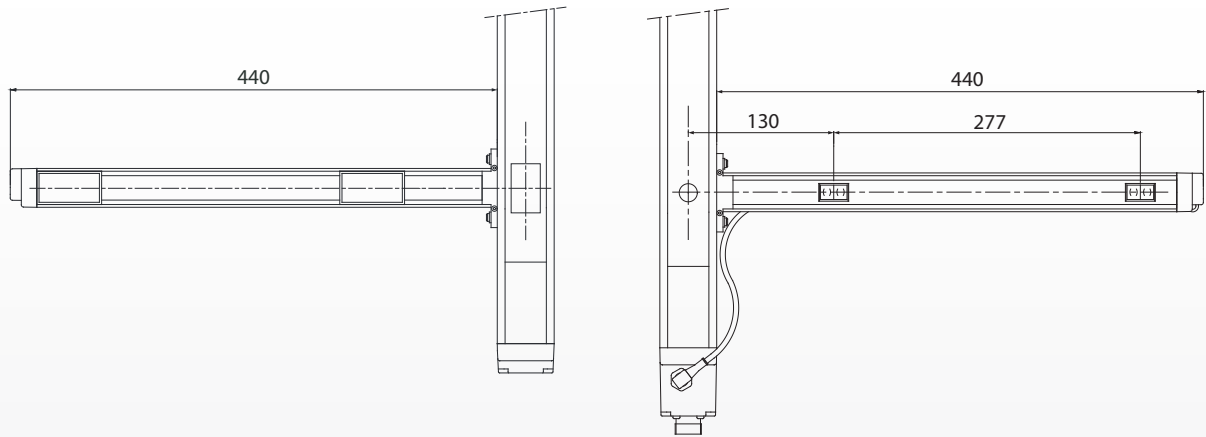

**Mounting:**

- 2B - Complete set of 4 type LL brackets included in the package.
- 3B - Complete set of 6 type LL brackets included in the package.

### JANUS MT TRX – MT TRX G

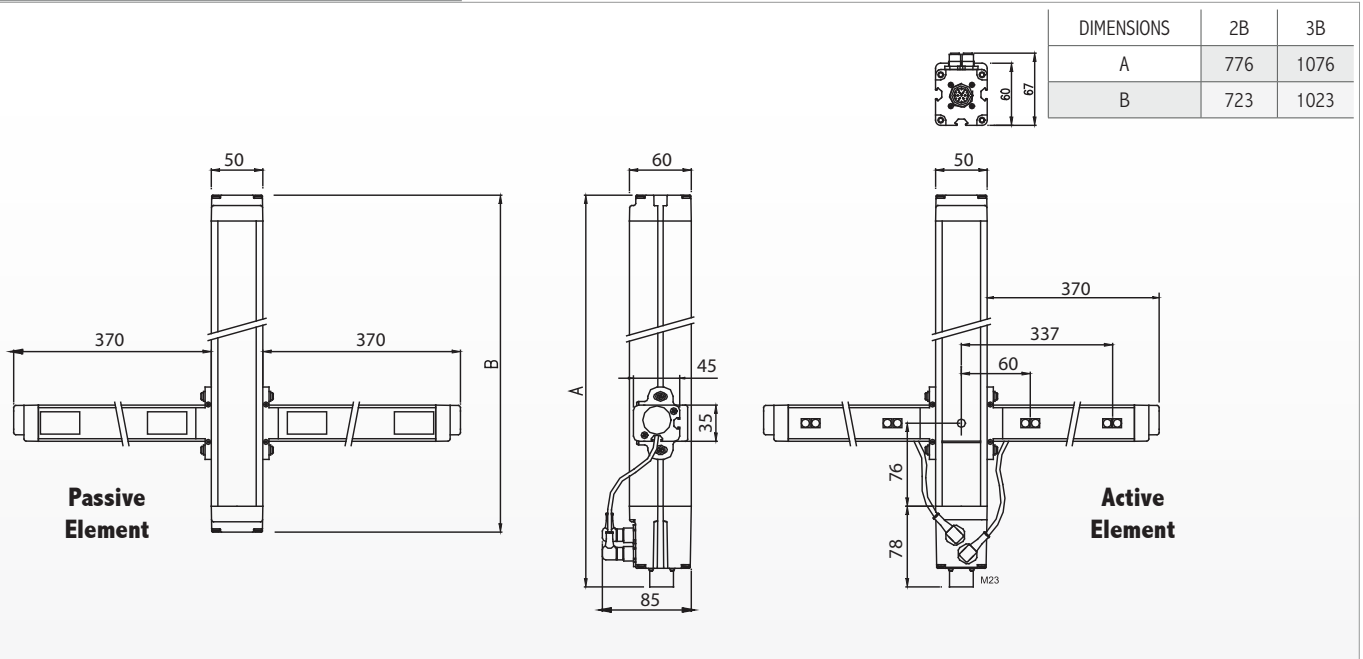

**Mounting:**

- 2B - Complete set of 4 type LL brackets included in the package.
- 3B - Complete set of 6 type LL brackets included in the package.



## JANUS MT TRX V

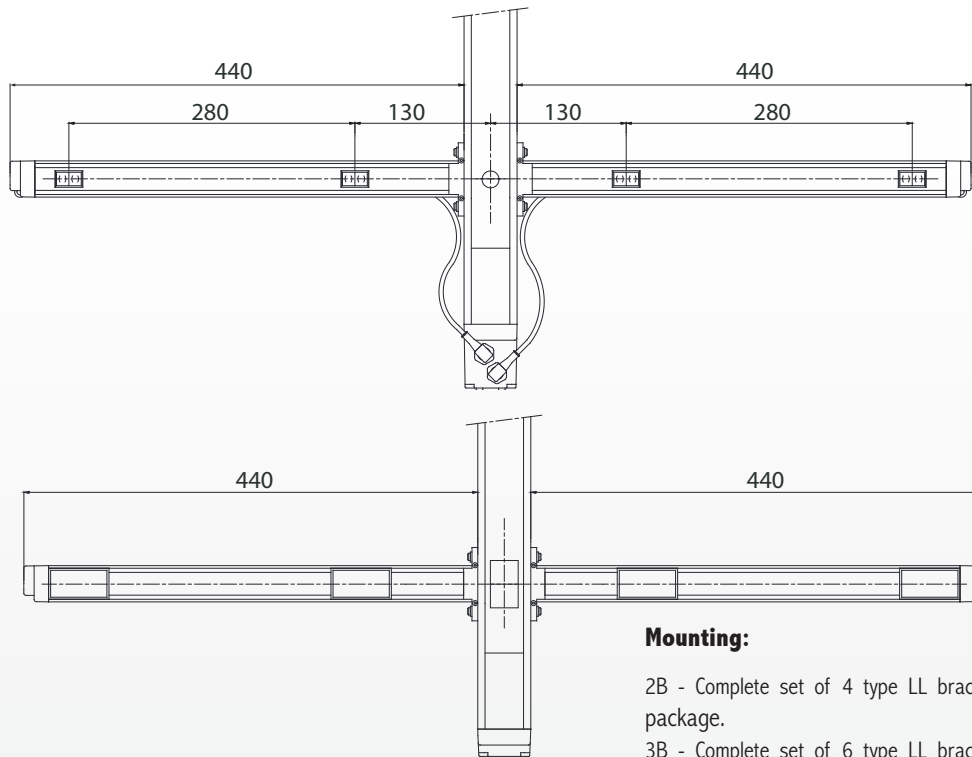

**Mounting:**

- 2B - Complete set of 4 type LL brackets included in the package.
- 3B - Complete set of 6 type LL brackets included in the package.



### WARNING!

In perimeter and/or long-range applications and with the use of deflection mirrors, we recommend using the LAD 3 laser alignment device to obtain a simple, quick, and correct alignment of the light curtains

In perimeter and/or long-range applications and with the use of deflection mirrors, we recommend using the FMC adjustable floor mounting columns. If the light curtain system is subject to strong vibrations (applications on presses, etc.), it is necessary to use the special SAV vibration dampers, available as accessories, to prevent mechanical damage to the light curtain elements.

## ORDERING INFORMATION

**Each Janus light curtain comprises:**

- Emitter and Receiver pair, including integrated sensor (only for L and T models)
- Emitter / Receiver active element + passive reflector element (only for models M TRX and J TRX)
- Mounting brackets and T-nuts
- CD-ROM containing the multi-language instruction manual complete with CE declaration of conformity
- Quick installation guide

## ACCESSORIES

**For Janus light curtains the following accessories, to be ordered separately, are available:**

AD SR Safety Relays	▶ See page 183
FMC floor mounting columns	▶ See page 220
SP deflection mirrors	▶ See page 223
LAD laser alignment device	▶ See page 224
SAV vibrations dampers	▶ See page 225
MJB:	▶ See page 105
Additional arms SL and ST	▶ See page 106
Connectors	▶ See list hereunder:

### CONNECTORS FOR RECEIVERS / TRX MODELS ACTIVE ELEMENTS

Models	Code	Description
CJ 3	1360950	M23 straight connector 19 poles pre-wired, cable 3 m
CJ 5	1360951	M23 straight connector 19 poles pre-wired, cable 5 m
CJ 10	1360952	M23 straight connector 19 poles pre-wired, cable 10 m
CJ 15	1360953	M23 straight connector 19 poles pre-wired, cable 15 m
CJ 20	1360954	M23 straight connector 19 poles pre-wired, cable 20 m
CJ 20L2	1360959	M23 straight connector 19 poles, pre-wired cable 20 m with 2 m long secondary cable for muting lamp
CJ 30	1360964	M23 straight connector 19 poles pre-wired, cable 30 m
CJ 30L2	1360979	M23 straight connector 19 poles, pre-wired cable 30 m with 2 m long secondary cable for muting lamp
CJ 35	1360965	M23 straight connector 19 poles pre-wired, cable 35 m
CJM 23	1360955	M23 straight connector, 19 poles, cable gland (to be soldered)

### CONNECTORS FOR EMITTERS

Models	Code	Description
CD 5	1330950	M12 straight connector 5 poles pre-wired, cable 5 m
CD 10	1330956	M12 straight connector 5 poles pre-wired, cable 10 m
CD 15	1330952	M12 straight connector 5 poles pre-wired, cable 15 m
CD 20	1330957	M12 straight connector 5 poles pre-wired, cable 20 m
CD 25	1330949	M12 straight connector 5 poles pre-wired, cable 25 m
CD50	1330965	M12 straight connector 5 poles pre-wired, cable 50 m
CDM 9	1330954	M12 straight connector, 5 poles, with screw terminal, cable gland

### CABLES WITH 2 CONNECTORS FOR JANUS RECEIVERS AND MJB BOXES CONNECTION

Models	Code	Description
CJBR 3	1360970	3 m pre-wired cable with 2 straight connectors, M23 19-pole
CJBR 5	1360971	5 m pre-wired cable with 2 straight connectors, M23 19-pole
CJBR 10	1360972	10 m pre-wired cable with 2 straight connectors, M23 19-pole

### CABLES WITH 2 CONNECTORS FOR JANUS EMITTERS AND MJB BOXES CONNECTION

Models	Code	Description
CIBE 3	1360960	3 m pre-wired cable with 2 straight connectors, M12 5-pole
CIBE 5	1360961	5 m pre-wired cable with 2 straight connectors, M12 5-pole
CIBE 10	1360962	10 m pre-wired cable with 2 straight connectors, M12 5-pole
CIBE 25	1360963	25 m pre-wired cable with 2 straight connectors, M12 5-pole

## CONNECTORS FOR MUTING SENSORS - JANUS MI SERIES

Models	Code	Description
CI 95	1360982	M12 90° angled male connector, 5 poles, pre-wired cable 5 m
CIM 9	1360983	M12 90° angled male connector, 5 poles, with screw terminal, cable gland PG9

## CONNECTORS FOR J TRX MODEL ACTIVE ELEMENT

Models	Code	Description
C8D 5	1330980	M12 straight connector, 8 poles, pre-wired cable 5 m
C8D 10	1330981	M12 straight connector, 8 poles, pre-wired cable 10 m
C8D 15	1330982	M12 straight connector, 8 poles, pre-wired cable 15 m
C8D 25	1330967	M12 straight connector, 8 poles, pre-wired cable 25 m
C8D 40	1330966	M12 straight connector, 8 poles, pre-wired cable 40 m
C8D 95	1330983	M12 90° angle connector, 8 poles, pre-wired cable 5 m
C8D 910	1330984	M12 90° angle connector, 8 poles, pre-wired cable 10 m
C8D 915	1330985	M12 90° angle connector, 8 poles, pre-wired cable 15 m
C8DM 11	1330987	M12 straight connector, 8 poles with screw terminal, PG9/11 cable gland
C8DM 911	1330979	M12 angle connector, 8 poles with screw terminal, PG9/11 cable gland

PHARO



 **GREER**

## PHARO

The PHARO Safety Laser Scanner is an optoelectronic protection device for accident prevention. PHARO is suitable for the protection of personnel exposed to risks deriving from both machines and systems with dangerous organs as well as from possible collisions with automatic guided vehicles (AGVs).

With the PHARO Safety Laser Scanner it is possible to create programmable protected horizontal or vertical areas of variable shape suitable to all applications without the need to use a separate reflector or receiver.

The device does not require an external control unit because all the safety functions are built-in.

The PHARO Safety Laser Scanner features a Configuration Memory Module built into the removable connector, which stores the data related to the protected zones programmed and to the operating parameters set.

This module enables the user to replace a faulty sensor with a new device without the need for reconfiguration and therefore maintaining the pre-existing configuration, without the possibility of errors or tampering. The stored data can only be modified by authorised personnel.

Each sensor can create 2 independently programmable controlled zones:

- 2 safety zones with maximum radius of 4 metres
- 2 warning zones with maximum radius of 20 metres.

<b>Model:</b>	<b>PHR 332</b>
<b>Protective (safety) fields:</b>	<b>2</b>
<b>Warning zones:</b>	<b>2</b>
<b>Configuration Memory Module:</b>	<b>Yes</b>



**Safety level: Type 3 – SIL 2 – SILCL 2 – PL d – Cat. 3**

- 2006/42/EC “Machinery Directive”
- 2004/108/EC “ Electromagnetic Compatibility (EMC)”
- 2006/95/EC “Low Voltage Directive (LVD)”
- IEC/EN 61496-1 Ed. 2 e IEC/TS 61496-3 “Safety of machinery - Electro-sensitive protective equipment- General requirements and tests”
- EN ISO 13849-1 “Safety of machinery – Safety-related parts of control systems – Part 1: General principles for design”
- IEC/EN 62061 “Safety of machinery – Functional safety of safety-related electrical, electronic and programmable electronic control systems”
- IEC 61508 “Functional safety of electrical/electronic/programmable electronic safety-related systems”
- IEC/TS 62046 Ed. 2 “Safety of machinery – Application of protective equipment to detect the presence of persons”
- UL (C+US) mark for USA and Canada
- ANSI / UL 1998 “Safety Software in Programmable Components”.

### MAIN FEATURES

Scanning area: 190° / 4 m radius.

Resolution configurable from 30 mm to 150 mm: from hand detection to access control.

Configuration software via RS232 serial port

2 safety zones and 2 warning zones, programmable.

Programming by means of:

- graphic user interface
- teach-in
- data transfer from file (from PC or from another laser scanner).

Configuration Memory Module for easy re-installation.

Detailed self-diagnosis via display and remote serial output.

Built-in start/restart interlock, selectable.

Feedback input for control of external relays (EDM).

### GENERAL TECHNICAL DATA

<b>Safety level</b>	Type 3 according to IEC/TS 61496-3 SIL 2 – SILCL 2 according to IEC 61508 - IEC 62061 PL d – Cat. 3 according to ISO 13849-1
<b>Light source</b>	laser diode wavelength 905 nm
<b>Laser source class</b>	1 - according to EN 60825-1
<b>Scanning angle</b>	190°
<b>Angular resolution</b>	0,25° ... 0,50°
<b>Response time (ms)</b>	configurable 60 or 120 (with 2 scans)
<b>Start/Restart</b>	automatic - timed automatic - manual reset (selectable via software)
<b>Serial interface - configuration</b>	RS 232
<b>Serial interface - data transmission</b>	RS 422
<b>Configuration and operating parameter setting</b>	via configuration software (UCS)
<b>Configuration Memory Module</b>	built into the main connector
<b>Signalling</b>	display indications in 7 segments and LEDs for self-diagnosis and sensor status
<b>Power supply (VDC)</b>	24 -30% +20%
<b>External relay control</b>	feedback input with enabling, selectable
<b>Main connection</b>	connector with screw terminals (13 poles cable)
<b>Serial interface connection for configuration</b>	cable pre-wired with 2 connectors: M8 4-pole / subD 9-pole
<b>Electrical connections</b>	max. cable length 30 m, cross-section 0.5 mm <sup>2</sup>
<b>Protection rating</b>	IP 65
<b>Operating temperature (°C)</b>	-10 ... 50

### SAFETY ZONE

<b>Max. range (m)</b>	4
<b>Resolution (mm)</b>	30, 40, 50, 70, 150 configurable
<b>Min. target reflectivity</b>	1,8%
<b>Safety outputs</b>	2 PNP self-testing - 500 mA at 24 VDC

### WARNING ZONE

<b>Max. range (m)</b>	20 (for objects with 20% reflectivity)
<b>Resolution (mm)</b>	depending on the distance of the obstacle
<b>Min. target reflectivity</b>	20% at 20 m
<b>Signalling outputs</b>	1 PNP - 200 mA at 24 VDC

## DIMENSIONS (mm)

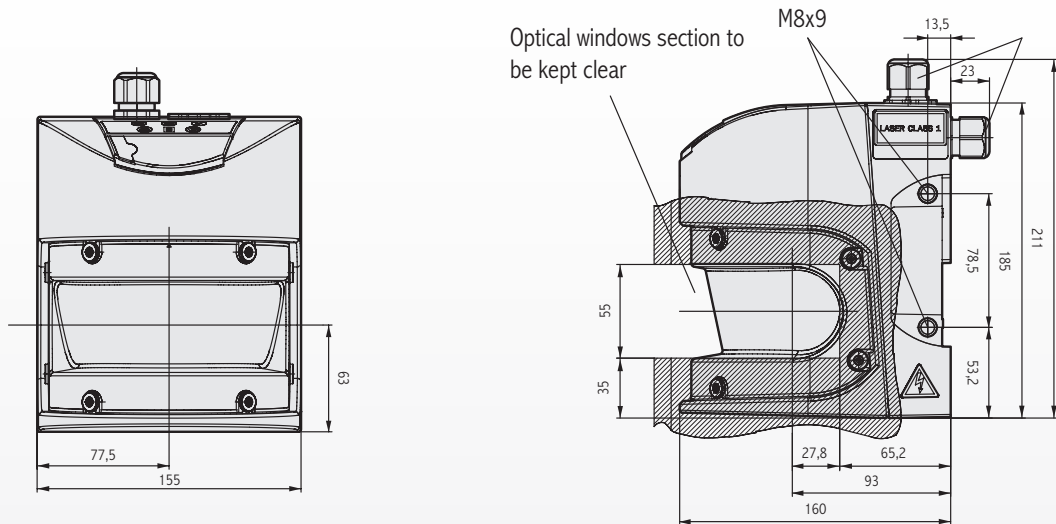

## INSTALLATION ACCESSORIES

### Special installation brackets are available for Pharo:

- Fixed bracket PHR B3
- Adjustable bracket PHR B4
- Floor mounting bracket PHR B5

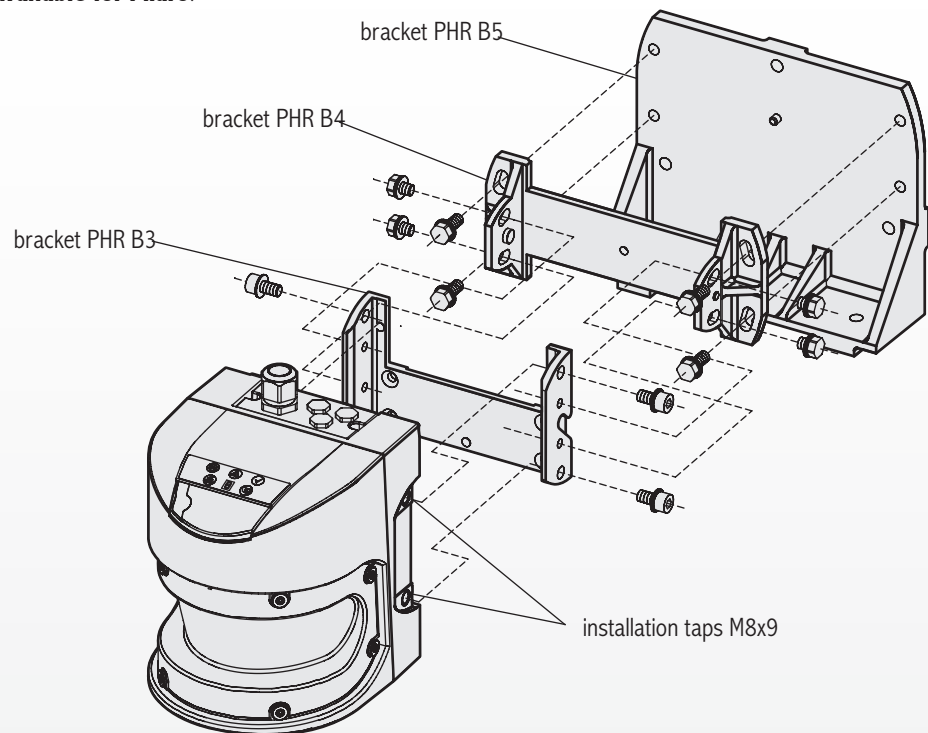

## ORDERING INFORMATION

**Each Pharo Laser Scanner includes:**

PHR 332 Laser Scanner - Ordering code: **1350041**

CD-ROM containing configuration software in English and Italian and multi-language instruction manual complete with CE declaration of conformity

## ACCESSORIES

The following accessories are available for Pharo, to be ordered separately:

Model	Code	Description
PHR C3L5	1350061	30 poles connector pre-wired with 13-wire cable 5 m long Built-in Configuration Memory Module
PHR CSL2	1350070	cable for serial connection between Pharo sensor and PC for configuring M8 4-pole / subD 9-pole connector, length 2 m
PHR B3	1350050	fixed attachment bracket
PHR B4	1350051	adjustable attachment bracket
PHR B5	1350052	floor mounting bracket

**WARNING!**

For the main connection of the Pharo laser scanner, it is necessary to provide a 13-wire cable with 0.56 mm<sup>2</sup> cross-section. This cable is supplied with the PHR C3L5 main connector.

To use the PHR B4 adjustable bracket it is also necessary to order the PHR B3 fixed bracket.

To use the PHR B5 floor mounting bracket it is also necessary to order the PHR B3 fixed bracket and the PHR B4 adjustable bracket.





# EOS 2



## EOS 2

EOS2 is a compact Type 2 light curtain with competitive performance and innovative features.

Its features include:

- Minimal cross section: 28 x 30 mm.
- No blind area on one side: the position of first beam ensures that the sensitive area extends to end of the light curtain.
- Minimal blind area on connector side.
- The solution with two L-mounted light curtains, e.g. Master-Slave, maintains 40 mm resolution in corner (models with resolution 30 and 40 mm).
- Easy connection and installation thanks to the M12 connectors and the use of unshielded cables up to 100 m.
- Integrated safety functions, including self-monitoring of static outputs, control of external contactors (EDM) and automatic/manual selectable Restart.
- Exceptional mechanical and electrical robustness are the result of extensive experience gained hands-on with all kinds of applications.
- Operating temperature range: -10 ... 55 °C.
- Protection rate: IP 65 and IP 67 at the same time.
- High resistance to infiltration by dust and liquids in a highly compact light curtain.
- Models Master/Slave for cascade connection of two or three light curtains.
- 2 safety PNP static outputs.

Special versions with IP 69K watertight enclosure (WTF and WTHF), also suitable for Food & Beverage industry, available.

► [See page 194](#)

Special models in conformity with the "ATEX Directive" 94/9/CE - Dust zone 22 - Gas Zone 2 available on request.

EOS2 light curtains may be connected to the dedicated safety interfaces series AD SR, or directly to contactors actuated and controlled by the light curtain, or to MOSAIC or to suitable commercial safety modules or safety PLCs.

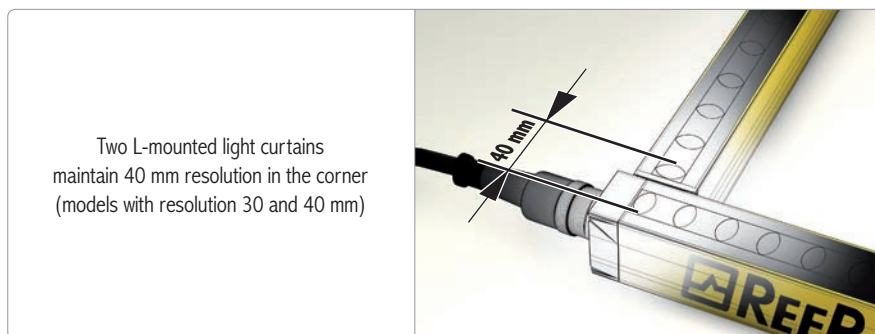

### Safety level: **Type 2 – SIL 2 – SILCL 2 – PL d – Cat. 2**

- 2006/42/EC "Machinery Directive"
- 2004/108/EC "Electromagnetic Compatibility (EMC)"
- 2006/95/EC "Low Voltage Directive (LVD)"
- IEC/EN 61496-1 Ed. 2.1, IEC/TS 61496-2 Ed. 2 "Safety of machinery - Electro-sensitive protective equipment- General requirements and tests"
- EN ISO 13849-1 "Safety of machinery – Safety-related parts of control systems – Part 1: General principles for design"
- IEC/EN 62061 "Safety of machinery – Functional safety of safety-related electrical, electronic and programmable electronic control systems"
- IEC 61508 "Functional safety of electrical/electronic/programmable electronic safety-related systems"
- IEC/TS 62046 Ed. 2 "Safety of machinery – Application of protective equipment to detect the presence of persons"
- UL (C+US) mark for USA and Canada
- ANSI / UL 1998 "Safety Software in Programmable Components".



### THE EOS2 RANGE

EOS2 A	EOS2 X	EOS4 XS - XM - XS2
Automatic Start/Restart	Built-in, selectable manual or automatic Start/Restart	Master and Slave models for series connection of two or three light curtains regardless of height or resolution
The ideal light curtain for straightforward interfacing with safety modules (i.e. AD SR1) or safety PLCs. (i.e. MOSAIC)	An effective light curtain for directly controlling and monitoring machine circuits with no need of external safety modules	Ideal solution for series connection of several light curtains and combined detection of hand and body or the protection of two different sides of a machine
External relay monitoring (EDM) through external AD SR1 interface, MOSAIC or safety PLCs	Feedback input for external relay monitoring (EDM)	
Electrical connections: M12 5-pole connectors	Electrical connections: M12 5-pole connector for emitter M12 8-pole for receiver	
Max. range 12 m		
Protected height range 160 to 1810 mm		
Types of detection: resolution 30, 40 mm for hand detection resolution 50, 90 mm for detection of the body in a dangerous area 2, 3, 4 beams for detection of the body in access control		
2 safety static outputs PNP with auto-test protected against short circuits and overloads		

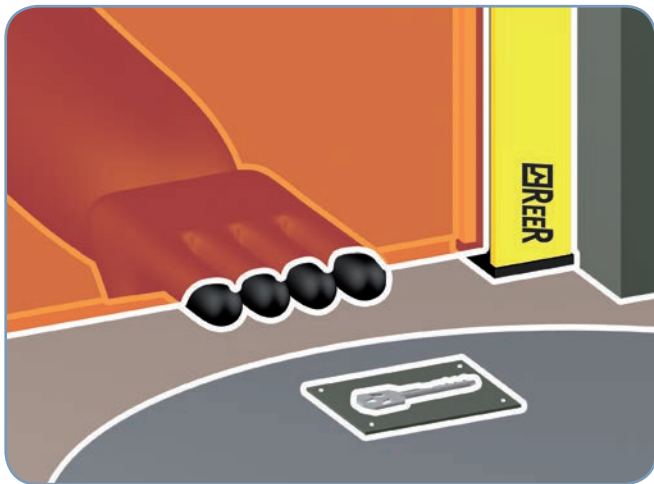

The protected area extends until the light curtain end maintaining the resolution



The resolution is maintained (up to 40 mm) in the junction between the 2 protected areas

# EOS2 A

## WITH AUTOMATIC START/RESTART

### MAIN FEATURES

Automatic Start/Restart.  
 Two safety PNP static outputs, auto-controlled.  
 All connections and configurations through M12 5-pole connectors.  
 Unshielded cables up to 100 meter long.  
 Start/Restart interlock and EDM through external AD SR1 interface.  
 Muting function through external AD SRM interface.  
 Autotest every 0.5 sec.

### TECHNICAL FEATURES

<b>Safety level</b>	Type 2 according to IEC/TS 61496-2 SIL 2 – SILCL 2 according to IEC 61508 - IEC 62061 PL d – Cat. 2 according to ISO 13849-1
<b>Protected heights (mm)</b>	160 ... 1810
<b>Resolutions (mm)</b>	30, 40, 50, 90
<b>Numbers of beams for body detection in access control</b>	2, 3, 4
<b>Max. range (m)</b>	4 or 12 selectable
<b>Response time (ms)</b>	2,5 ... 18,5
<b>Safety outputs</b>	2 PNP - 400 mA at 24 VDC with short-circuit, overload, polarity reversal protection
<b>Signaling</b>	LEDs for light curtain's status and diagnostic
<b>Start/Restart</b>	automatic
<b>Power supply (VDC)</b>	24 ± 20%
<b>Electrical connections</b>	M12 5-pole for emitter and receiver
<b>Max. cable length (m)</b>	100
<b>Operating temperature (°C)</b>	-10 ... 55
<b>Protection rating</b>	IP 65 and IP 67
<b>Fastening modes</b>	back slot or to the top and lower end by rotating brackets SFB E180 (optional)
<b>Cross section (mm)</b>	28 x 30



Emitter - 5 poles

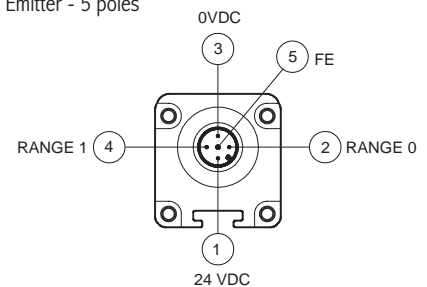

Receiver - 5 poles

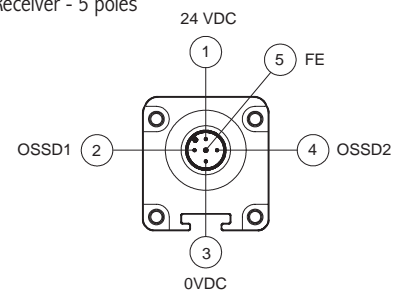

Safety level:

**TYPE 2**

**SIL 2 – SILCL 2**  
**PL d – Cat. 2**



# TYPE 2 SAFETY LIGHT CURTAIN

## EOS2 A

WITH AUTOMATIC START/RESTART



Resolution 30 mm	EOS2 153 A	EOS2 253 A	EOS2 303 A	EOS2 453 A	EOS2 603 A	EOS2 753 A	EOS2 903 A	EOS2 1053 A	EOS2 1203 A	EOS2 1353 A	EOS2 1503 A	EOS2 1653 A	EOS2 1803 A
Ordering codes	<b>1320200</b>	<b>1321205</b>	<b>1320201</b>	<b>1320202</b>	<b>1320203</b>	<b>1320204</b>	<b>1320205</b>	<b>1320206</b>	<b>1320207</b>	<b>1320208</b>	<b>1320209</b>	<b>1320270</b>	<b>1320271</b>
Protected height (mm)	160	260	310	460	610	760	910	1060	1210	1360	1510	1660	1810
Number of beams	8	13	16	23	31	38	46	53	61	68	76	83	91
Overall height (mm)	213	313	363	513	663	813	963	1113	1263	1413	1563	1713	1863



Resolution 40 mm	EOS2 154 A	EOS2 254 A	EOS2 304 A	EOS2 454 A	EOS2 604 A	EOS2 754 A	EOS2 904 A	EOS2 1054 A	EOS2 1204 A	EOS2 1354 A	EOS2 1504 A	EOS2 1654 A	EOS2 1804 A
Ordering codes	<b>1320300</b>	<b>1321202</b>	<b>1320301</b>	<b>1320302</b>	<b>1320303</b>	<b>1320304</b>	<b>1320305</b>	<b>1320306</b>	<b>1320307</b>	<b>1320308</b>	<b>1320309</b>	<b>1320370</b>	<b>1320371</b>
Protected height (mm)	160	260	310	460	610	760	910	1060	1210	1360	1510	1660	1810
Number of beams	6	9	11	16	21	26	31	36	41	46	51	56	61
Overall height (mm)	213	313	363	513	663	813	963	1113	1263	1413	1563	1713	1863



Resolution 50 mm	EOS2 155 A	EOS2 305 A	EOS2 455 A	EOS2 605 A	EOS2 755 A	EOS2 905 A	EOS2 1055 A	EOS2 1205 A	EOS2 1355 A	EOS2 1505 A	EOS2 1655 A	EOS2 1805 A
Ordering codes	<b>1320400</b>	<b>1320401</b>	<b>1320402</b>	<b>1320403</b>	<b>1320404</b>	<b>1320405</b>	<b>1320406</b>	<b>1320407</b>	<b>1320408</b>	<b>1320409</b>	<b>1320470</b>	<b>1320471</b>
Protected height (mm)	160	310	460	610	760	910	1060	1210	1360	1510	1660	1810
Number of beams	4	8	12	16	20	24	28	32	36	40	44	48
Overall height (mm)	213	363	513	663	813	963	1113	1263	1413	1563	1713	1863



Resolution 90 mm	EOS2 309 A	EOS2 459 A	EOS2 609 A	EOS2 759 A	EOS2 909 A	EOS2 1059 A	EOS2 1209 A	EOS2 1359 A	EOS2 1509 A	EOS2 1659 A	EOS2 1809 A
Ordering codes	<b>1320501</b>	<b>1320502</b>	<b>1320503</b>	<b>1320504</b>	<b>1320505</b>	<b>1320506</b>	<b>1320507</b>	<b>1320508</b>	<b>1320509</b>	<b>1320570</b>	<b>1320571</b>
Protected height (mm)	310	460	610	760	910	1060	1210	1360	1510	1660	1810
Number of beams	4	6	8	10	12	14	16	18	20	22	24
Overall height (mm)	363	513	663	813	963	1113	1263	1413	1563	1713	1863



2, 3, 4 beams	EOS2 2B A	EOS2 3B A	EOS2 4B A
Ordering codes	<b>1320600</b>	<b>1320601</b>	<b>1320602</b>
Number of beams	2	3	4
Beam spacing (mm)	500	400	300
Protected height (mm)	510	810	910
Overall height (mm)	653	953	1053

► "ACCESSORIES" on page 132

# EOS2 X

## WITH BUILT-IN CONTROL FUNCTIONS

### MAIN FEATURES

- Built-in, selectable manual/automatic Start/Restart.
- Feedback input for controlling external relays (EDM).
- Two safety PNP static outputs, auto-controlled.
- All connections and setting adjustments through M12 5-pole and 8-pole connectors.
- Unshielded cables up to 100 meter long.
- Master and Slave models for series connection of up to 3 light curtains.
- Max. length of connections toward Slaves: 50 meters, through standard unshielded cable.
- Autotest every 0.5 sec.

### TECHNICAL FEATURES

<b>Safety level</b>	Type 2 according to IEC/TS 61496-2 SIL 2 – SILCL 2 according to IEC 61508 - IEC 62061 PL d – Cat. 2 according to ISO 13849-1
<b>Protected heights (mm)</b>	160 ... 1810
<b>Resolutions (mm)</b>	30, 40, 50, 90
<b>Numbers of beams for body detection in access control</b>	2, 3, 4
<b>Max. range (m)</b>	4 or 12 selectable
<b>Response time (ms)</b>	2,5 ... 18,5
<b>Safety outputs</b>	2 PNP - 400 mA at 24 VDC with short-circuit, overload, polarity reversal protection
<b>Signaling</b>	LEDs for light curtain's status and diagnostic
<b>Start/Restart</b>	selectable automatic or manual
<b>External Device Monitoring</b>	external device monitoring feedback input with enabling, selectable
<b>Power supply (VDC)</b>	24 ± 20%
<b>Electrical connections for EOS2 X and EOS2 X Master</b>	M12 5-pole for emitter M12 8-pole for receiver
<b>Electrical connections between Master and Slave</b>	M12 5-pole per emitter and receiver
<b>Max. cable length (m)</b>	100 (50 between Master and Slave)
<b>Operating temperature (°C)</b>	-10 ... 55
<b>Protection rating</b>	IP 65 and IP 67
<b>Fastening modes</b>	back slot
<b>Cross section (mm)</b>	28 x 30

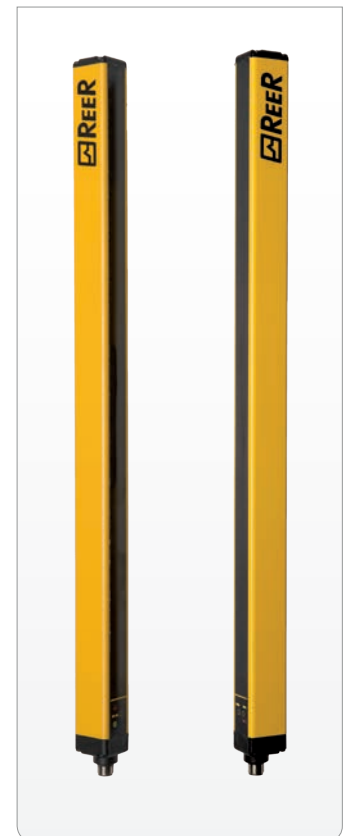

Emitter - 5 poles

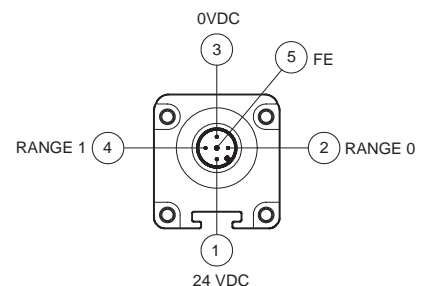

Receiver - 8 poles

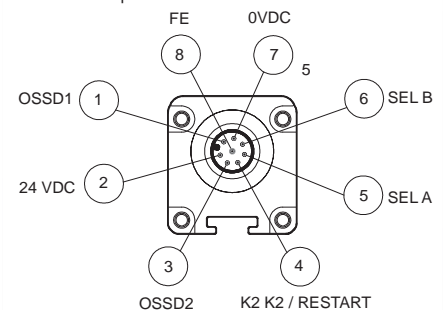

Safety level:

# TYPE 2

SIL 2 – SILCL 2  
PL d – Cat. 2



# TYPE 2 SAFETY LIGHT CURTAIN

## EOS2 X

WITH BUILT-IN CONTROL FUNCTIONS



Resolution 30 mm	EOS2 153 X	EOS2 253 X	EOS2 303 X	EOS2 453 X	EOS2 603 X	EOS2 753 X	EOS2 903 X	EOS2 1053 X	EOS2 1203 X	EOS2 1353 X	EOS2 1503 X	EOS2 1653 X	EOS2 1803 X
Ordering codes	<b>1320210</b>	<b>1321200</b>	<b>1320211</b>	<b>1320212</b>	<b>1320213</b>	<b>1320214</b>	<b>1320215</b>	<b>1320216</b>	<b>1320217</b>	<b>1320218</b>	<b>1320219</b>	<b>1320272</b>	<b>1320273</b>
Protected height (mm)	160	260	310	460	610	760	910	1060	1210	1360	1510	1660	1810
Number of beams	8	13	16	23	31	38	46	53	61	68	76	83	91
Overall height (mm)	213	313	363	513	663	813	963	1113	1263	1413	1563	1713	1863



Resolution 40 mm	EOS2 154 X	EOS2 254 X	EOS2 304 X	EOS2 454 X	EOS2 604 X	EOS2 754 X	EOS2 904 X	EOS2 1054 X	EOS2 1204 X	EOS2 1354 X	EOS2 1504 X	EOS2 1654 X	EOS2 1804 X
Ordering codes	<b>1320310</b>	<b>1321209</b>	<b>1320311</b>	<b>1320312</b>	<b>1320313</b>	<b>1320314</b>	<b>1320315</b>	<b>1320316</b>	<b>1320317</b>	<b>1320318</b>	<b>1320319</b>	<b>1320372</b>	<b>1320373</b>
Protected height (mm)	160	260	310	460	610	760	910	1060	1210	1360	1510	1660	1810
Number of beams	6	8	11	16	21	26	31	36	41	46	51	56	61
Overall height (mm)	213	313	363	513	663	813	963	1113	1263	1413	1563	1713	1863



Resolution 50 mm	EOS2 155 X	EOS2 305 X	EOS2 455 X	EOS2 605 X	EOS2 755 X	EOS2 905 X	EOS2 1055 X	EOS2 1205 X	EOS2 1355 X	EOS2 1505 X	EOS2 1655 X	EOS2 1805 X
Ordering codes	<b>1320410</b>	<b>1320411</b>	<b>1320412</b>	<b>1320413</b>	<b>1320414</b>	<b>1320415</b>	<b>1320416</b>	<b>1320417</b>	<b>1320418</b>	<b>1320419</b>	<b>1320472</b>	<b>1320473</b>
Protected height (mm)	160	310	460	610	760	910	1060	1210	1360	1510	1660	1810
Number of beams	4	8	12	16	20	24	28	32	36	40	44	48
Overall height (mm)	213	363	513	663	813	963	1113	1263	1413	1563	1713	1863



Resolution 90 mm	EOS2 309 X	EOS2 459 X	EOS2 609 X	EOS2 759 X	EOS2 909 X	EOS2 1059 X	EOS2 1209 X	EOS2 1359 X	EOS2 1509 X	EOS2 1659 X	EOS2 1809 X
Ordering codes	<b>1320511</b>	<b>1320512</b>	<b>1320513</b>	<b>1320514</b>	<b>1320515</b>	<b>1320516</b>	<b>1320517</b>	<b>1320518</b>	<b>1320519</b>	<b>1320572</b>	<b>1320573</b>
Protected height (mm)	310	460	610	760	910	1060	1210	1360	1510	1660	1810
Number of beams	4	6	8	10	12	14	16	18	20	22	24
Overall height (mm)	363	513	663	813	963	1113	1263	1413	1563	1713	1863



2, 3, 4 beams	EOS2 2B X	EOS2 3B X	EOS2 4B X
Ordering codes	<b>1320610</b>	<b>1320611</b>	<b>1320612</b>
Number of beams	2	3	4
Beam spacing (mm)	500	400	300
Protected height (mm)	510	810	910
Overall height (mm)	653	953	1053

► "ACCESSORIES" on page 132



# EOS2 XS - XM - XS2

## MASTER / SLAVE MODELS WITH BUILT-IN CONTROL FUNCTIONS

### MASTER/SLAVE MODELS

Master/Slave models permit series connection of up to three safety light curtains and combined detection of hand and presence of a person or of more sides of the machine, with the following major benefits:

- A single pair of safety outputs
- No interference between light curtains installed adjacent to one another.

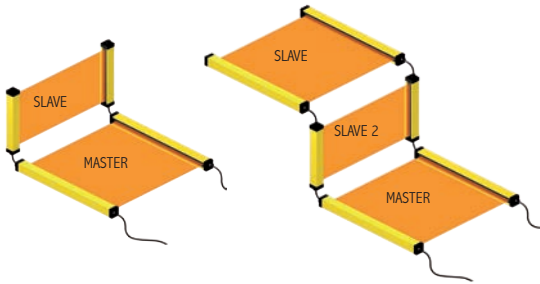

### EXAMPLES OF SERIES CONNECTION OF MASTER AND SLAVE LIGHT CURTAINS

**Any Master model can be used together with any Slave model.**

All electrical connections are made using M12 5-pole connectors, except for Master receivers which necessitate the adoption of M12 8-pole connectors.

Pre-wired cables with twin connectors are available for the connection between Master and Slave.

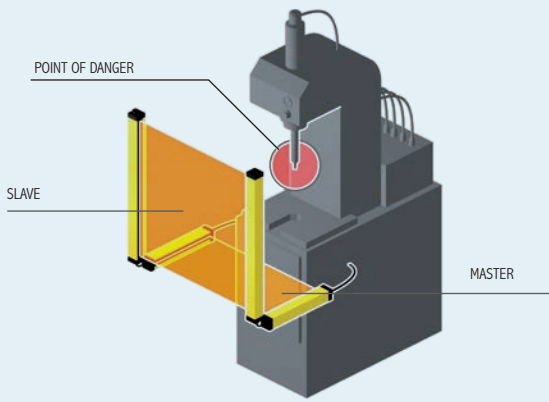

### EXAMPLES OF SERIES CONNECTION OF MASTER AND SLAVE LIGHT CURTAINS

Master light curtain is placed horizontally for detection of the person and Slave light curtain is placed vertically to detect fingers or hands.

The arrangement can be reversed to have the Master light curtain vertical for finger and hand detection and the Slave light curtain horizontally for detecting the presence of a person.

The application shown is one of the most common: horizontal curtains are used to prevent the operator from being undetected in the space between vertical light curtain and dangerous machine, upon system start-up or restarting.

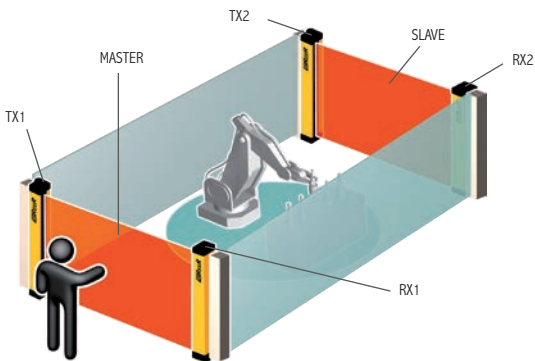

### EXAMPLE OF SERIES CONNECTION OF MASTER AND SLAVE LIGHT CURTAINS FOR PROTECTION OF TWO SIDES OF THE MACHINE

On EOS2 X the connecting cable across Master and Slave is a standard (unshielded) cable up to 50 meter long.

Thus, two series connected curtains may be located one at the front of the machine and the other at the rear, with a single connection to the machine power and control circuitry.

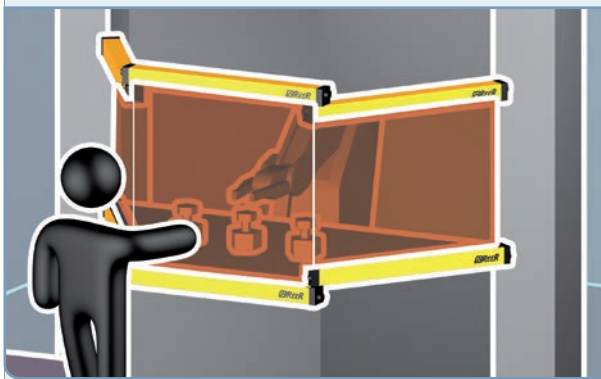

### EXAMPLE OF SERIES CONNECTION OF ONE MASTER AND TWO SLAVE LIGHT CURTAINS FOR THE PROTECTION OF THREE SIDES OF THE MACHINE

Benefit: unimpeded operator access to work area from front and sides.

## EOS2 XS - XM - XS2

### MASTER / SLAVE MODELS WITH BUILT-IN CONTROL FUNCTIONS

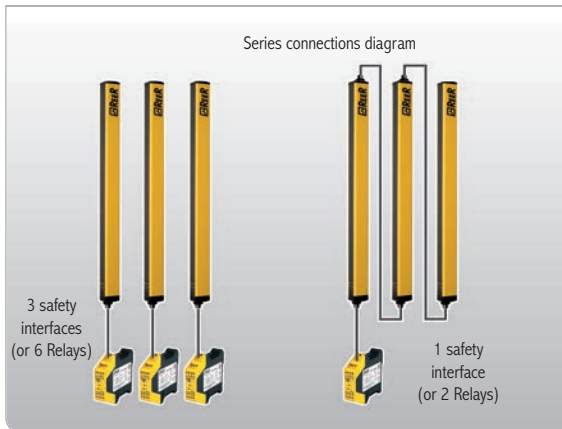

**Benefit:**

with three standard curtains it will be necessary to use and wire up 3 safety interfaces or 6 contactors.

With the master/slave solution having 3 series light curtains it will be enough to use and wire up only 1 safety interface or 2 contactors.

### MASTER/SLAVE MODELS



<b>MASTER Resolution 30 mm</b>	-	EOS 2 253 XM	EOS2 303 XM	EOS2 453 XM	EOS2 603 XM	EOS2 753 XM	EOS2 903 XM	EOS2 1053 XM	EOS2 1203 XM	EOS2 1353 XM	EOS2 1503 XM	EOS2 1653 XM	EOS2 1803 XM
Ordering codes	-	1321206	1320221	1320222	1320223	1320224	1320225	1320226	1320227	1320228	1320229	1320274	1320275
<b>SLAVE Resolution 30 mm</b>	EOS2 153 XS	EOS 2 253 XS	EOS2 303 XS	EOS2 453 XS	EOS2 603 XS	EOS2 753 XS	EOS2 903 XS	EOS2 1053 XS	EOS2 1203 XS	EOS2 1353 XS	EOS2 1503 XS	EOS2 1653 XS	EOS2 1803 XS
Ordering codes	1320230	1321207	1320231	1320232	1320233	1320234	1320235	1320236	1320237	1320237	1320239	1320276	1320277
<b>SLAVE 2 Resolution 30 mm</b>	-	EOS 2 253 XM2	EOS2 303 XS2	EOS2 453 XS2	EOS2 603 XS2	EOS2 753 XS2	EOS2 903 XS2	EOS2 1053 XS2	EOS2 1203 XS2	EOS2 1353 XS2	EOS2 1503 XS2	EOS2 1653 XS2	EOS2 1803 XS2
Ordering codes	-	1321208	1320241	1320242	1320243	1320244	1320245	1320246	1320247	1320248	1320249	1320278	1320279
Protected height (mm)	160	260	310	460	610	760	910	1060	1210	1360	1510	1660	1810
Number of beams	8	13	16	23	31	38	46	53	61	68	76	83	91
Overall height (mm)	236.5	336.5	386.5	536.5	686.5	836.5	986.5	1136.5	1286.5	1436.5	1586.5	1736.5	1886.5



<b>MASTER Resolution 40 mm</b>	-	EOS2 254 XM	EOS2 304 XM	EOS2 454 XM	EOS2 604 XM	EOS2 754 XM	EOS2 904 XM	EOS2 104 XM	EOS2 1204 XM	EOS2 1354 XM	EOS2 1504 XM	EOS2 1654 XM	EOS2 1804 XM
Ordering codes	-	1321210	1320321	1320322	1320323	1320324	1320325	1320326	1320327	1320328	1320329	1320374	1320375
<b>SLAVE Resolution 40 mm</b>	EOS2 154 XS	EOS2 254 XS	EOS2 304 XS	EOS2 454 XS	EOS2 604 XS	EOS2 754 XS	EOS2 904 XS	EOS2 1054 XS	EOS2 1204 XS	EOS2 1354 XS	EOS2 1504 XS	EOS2 1654 XS	EOS2 1804 XS
Ordering codes	1320330	1321211	1320331	1320332	1320333	1320334	1320335	1320336	1320337	1320338	1320339	1320376	1320377
<b>SLAVE 2 Resolution 40 mm</b>	-	EOS2 254 XM2	EOS2 304 XS2	EOS2 454 XS2	EOS2 604 XS2	EOS2 754 XS2	EOS2 904 XS2	EOS2 1054 XS2	EOS2 1204 XS2	EOS2 1354 XS2	EOS2 1504 XS2	EOS2 1654 XS2	EOS2 1804 XS2
Ordering codes	-	1321212	1320341	1320342	1320343	1320344	1320345	1320346	1320347	1320348	1320349	1320378	1320379
Protected height (mm)	160	260	310	460	610	760	910	1060	1210	1360	1510	1660	1810
Number of beams	6	9	11	16	21	26	31	36	41	46	51	56	61
Overall height (mm)	236.5	336.5	386.5	536.5	686.5	836.5	986.5	1136.5	1286.5	1436.5	1586.5	1736.5	1886.5

► "ACCESSORIES" on page 132

# EOS2 XS - XM - XS2

## MASTER / SLAVE MODELS WITH BUILT-IN CONTROL FUNCTIONS



<b>MASTER</b> Resolution 50 mm	-	EOS2 305 XM	EOS2 455 XM	EOS2 605 XM	EOS2 755 XM	EOS2 905 XM	EOS2 105 XM	EOS2 1205 XM	EOS2 1355 XM	EOS2 1505 XM	EOS2 1655 XM	EOS2 1805 XM
Ordering codes		1320421	1320422	1320423	1320424	1320425	1320426	1320427	1320428	1320429	1320474	1320475
<b>SLAVE</b> Resolution 50 mm	EOS2 155 XS	EOS2 305 XS	EOS2 455 XS	EOS2 605 XS	EOS2 755 XS	EOS2 905 XS	EOS2 1055 XS	EOS2 1205 XS	EOS2 1355 XS	EOS2 1505 XS	EOS2 1655 XS	EOS2 1805 XS
Ordering codes	1320430	1320431	1320432	1320433	1320434	1320435	1320436	1320437	1320438	1320439	1320476	1320477
<b>SLAVE 2</b> Resolution 50 mm	-	EOS2 305 XS2	EOS2 455 XS2	EOS2 605 XS2	EOS2 755 XS2	EOS2 905 XS2	EOS2 1055 XS2	EOS2 1205 XS2	EOS2 1355 XS2	EOS2 1505 XS2	EOS2 1655 XS2	EOS2 1805 XS2
Ordering codes	-	1320441	1320442	1320443	1320444	1320445	1320446	1320447	1320448	1320449	1320478	1320479
Protected height (mm)	160	310	460	610	760	910	1060	1210	1360	1510	1660	1810
Number of beams	4	8	12	16	20	24	28	32	36	40	44	48
Overall height (mm)	236.5	386.5	536.5	686.5	836.5	986.5	1136.5	1286.5	1436.5	1586.5	1736.5	1886.5



<b>MASTER</b> Resolution 90 mm	EOS2 309 XM	EOS2 459 XM	EOS2 609 XM	EOS2 759 XM	EOS2 909 XM	EOS2 1059 XM	EOS2 1209 XM	EOS2 1359 XM	EOS2 1509 XM	EOS2 1659 XM	EOS2 1809 XM
Ordering codes	1320521	1320522	1320523	1320524	1320525	1320526	1320527	1320528	1320529	1320574	1320575
<b>SLAVE</b> Resolution 90 mm	EOS2 309 XS	EOS2 459 XS	EOS2 609 XS	EOS2 759 XS	EOS2 909 XS	EOS2 1059 XS	EOS2 1209 XS	EOS2 1359 XS	EOS2 1509 XS	EOS2 1659 XS	EOS2 1809 XS
Ordering codes	1320531	1320532	1320533	1320534	1320535	1320536	1320537	1320538	1320539	1320576	1320577
<b>SLAVE 2</b> Resolution 90 mm	EOS2 309 XS2	EOS2 459 XS2	EOS2 609 XS2	EOS2 759 XS2	EOS2 909 XS2	EOS2 1059 XS2	EOS2 1209 XS2	EOS2 1359 XS2	EOS2 1509 XS2	EOS2 1659 XS2	EOS2 1809 XS2
Ordering codes	1320541	1320542	1320543	1320544	1320545	1320546	1320547	1320548	1320549	1320578	1320579
Protected heights (mm)	310	460	610	760	910	1060	1210	1360	1510	1660	1810
Number of beams	4	6	8	10	12	14	16	18	20	22	24
Overall height (mm)	386.5	536.5	686.5	836.5	986.5	1136.5	1266.5	1436.5	1586.5	1736.5	1886.5



<b>MASTER 2, 3, 4 beams</b>	<b>EOS2 2B XM</b>	<b>EOS2 3B XM</b>	<b>EOS2 4B XM</b>
Ordering codes	1320620	1320621	1320622
<b>SLAVE 2, 3, 4 beams</b>	<b>EOS2 2B XS</b>	<b>EOS2 3B XS</b>	<b>EOS2 4B XS</b>
Ordering codes	1320630	1320631	1320632
<b>SLAVE 2 2, 3, 4 beams</b>	<b>EOS2 2B XS2</b>	<b>EOS2 3B XS2</b>	<b>EOS2 4B XS2</b>
Ordering codes	1320640	1320641	1320642
Number of beams	2	3	4
Beam spacing (mm)	500	400	300
Protected heights (mm)	510	810	910
Overall height barrier* (mm)	677	977	1077

\* On slave models, the overall height of the light curtain is the same of the standard model.

On master and slave models 2 the total height of curtain is 24 mm greater owing to the addition of a secondary connector.

▶ **"ACCESSORIES" on page 132**

### DIMENSIONS (mm)

**EOS2 / EOS2 SLAVE**

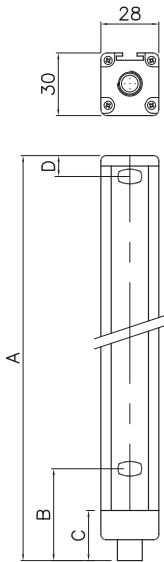

**EOS2 MASTER / EOS2 SLAVE 2**

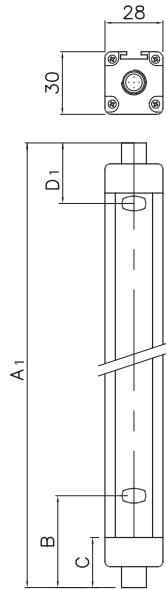

Model	2B	3B	4B
A	653	953	1053
A (Master/Slave2)	677	977	1077
B	102		
C	29,5		
D	51		
D (Master/Slave2)	75		

Model	150	250	300	450	600	750	900	1050	1200	1350	1500	1650	1800
A	213	313	363	513	663	813	963	1113	1263	1413	1563	1713	1886
A1 (Master/Slave2)	236.5	336.5	386.5	536.5	686.5	836.5	986.5	1136.5	1286.5	1436.5	1586.5	1736.5	1908.5
B	61.5												
C	29.5												
D	11												
D1 (Master/Slave2)	34.5												
Mounting	Complete set of 4 LE type brackets included in the package								Complete set of 6 LE type brackets included in the package				



### WARNING!

Where the light curtain is subjected to strong vibrations (presses, textile looms, etc.) always use vibrations dampers SAV E (available as accessories) in order to prevent damaging the light curtain.

Where protections are to be placed over long distances or on several sides using deflection mirrors, it is advisable to use laser alignment aid LAD 4 to ensure simple, quick and perfect alignment of light curtains.

### ORDERING INFORMATION

**Each EOS2 light curtain comprises:**

Emitter and Receiver pair	CD-ROM containing the multi-language instruction manual complete with CE declaration of conformity
Brackets and inserts	Quick installation guide

## ACCESSORIES

**EOS2 curtains can be supplied with the following accessories, to be ordered separately:**

AD SR Safety Relays	▶ See page 183
FMC floor mounting columns	▶ See page 220
SP deflection mirrors	▶ See page 223
LAD laser alignment device	▶ See page 224
SAV E vibrations dampers	▶ See page 225
SFB swivel fixing brackets	▶ See page 226
Connectors	▶ See list hereunder:

### CONNECTORS EOS2 (EOS2 A emitter and receiver / EOS2 X emitter)

Model	Code	Description
CD 5	1330950	M12 straight connector, 5 poles, pre-wired cable 5 m
CD 10	1330956	M12 straight connector, 5 poles, pre-wired cable 10 m
CD 15	1330952	M12 straight connector, 5 poles, pre-wired cable 15 m
CD 20	1330957	M12 straight connector, 5 poles, pre-wired cable 20 m
CD 25	1330949	M12 straight connector, 5 poles, pre-wired cable 25 m
CD 50	1330965	M12 straight connector, 5 poles, pre-wired cable 50 m
CD 95	1330951	M12 90° angle connector, 5 poles, pre-wired cable 5 m
CD 910	1330958	M12 90° angle connector, 5 poles, pre-wired cable 10 m
CD 915	1330953	M12 90° angle connector, 5 poles, pre-wired cable 15 m
CDM 9	1330954	M12 straight connector, 5 poles with screw terminal, PG9 cable gland
CDM 99	1330955	M12 angle connector, 5 poles with screw terminal, PG9 cable gland

### CONNECTORS EOS2 X receivers

Model	Code	Description
C8D 5	1330980	M12 straight connector, 8 poles, pre-wired cable 5 m
C8D 10	1330981	M12 straight connector, 8 poles, pre-wired cable 10 m
C8D 15	1330982	M12 straight connector, 8 poles, pre-wired cable 15 m
C8D 25	1330967	M12 straight connector, 8 poles, pre-wired cable 25 m
C8D 40	1330966	M12 straight connector, 8 poles, pre-wired cable 40 m
C8D 95	1330983	M12 90° angle connector, 8 poles, pre-wired cable 5 m
C8D 910	1330984	M12 90° angle connector, 8 poles, pre-wired cable 10 m
C8D 915	1330985	M12 90° angle connector, 8 poles, pre-wired cable 15 m
C8DM 11	1330978	M12 straight connector, 8 poles with screw terminal, PG9/11 cable gland
C8DM 911	1330979	M12 90° angle connector, 8 poles with screw terminal, PG9/11 cable gland

### CONNECTION BETWEEN MASTER AND SLAVE

Model	Code	Description
CDS 03	1330990	0,3 m pre-wired cable with 2 straight connectors, M12 5-pole
CIBE 3	1360960	3 m pre-wired cable with 2 straight connectors, M12 5-pole
CIBE 5	1360961	5 m pre-wired cable with 2 straight connectors, M12 5-pole
CIBE 10	1360962	10 m pre-wired cable with 2 straight connectors, M12 5-pole
CIBE 25	1360963	25 m pre-wired cable with 2 straight connectors, M12 5-pole

# VISION



## VISION

The Vision Type 2 family of safety light curtains is the ideal solution for the protection of the majority of industrial applications in Category 2.

Its features include:

- Extremely easy connection and installation, thanks to the M12 connectors and the use of standard cables.
- Integration of the main safety functions, including self monitoring of the safety circuits and, for the VX / VXL / MXL models, external device monitoring (EDM) and the Start / Restart interlock function.
- The built-in auto-test function, activated automatically and periodically, without interruption of the operation of the machine being controlled.
- The breadth of the range, including Master / Slave models for cascade connection of two light curtains, the VXL models, with the lowest cost/performance ratio and the MXL models with built-in Muting function.
- The utmost reliability in the field, thanks to the rugged construction and to the high level of immunity to external disturbances (optical, EMC, etc.).

Special versions in WT/WTH watertight housing available on request.

► [See page 197](#)

Vision light curtains may be connected to the dedicated safety interfaces series AD SR, or directly to contactors actuated and controlled by the light curtain, or to MOSAIC or to suitable commercial safety modules or safety PLCs.

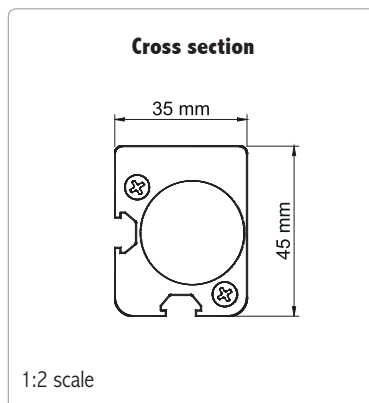

### Safety level: **Type 2 – SIL 2 – SILCL 2 – PL d – Cat. 2**



- 2006/42/EC “Machinery Directive”
- 2004/108/EC “ Electromagnetic Compatibility (EMC)”
- 2006/95/EC “Low Voltage Directive (LVD)”
- IEC/EN 61496-1 Ed. 2.1, IEC/TS 61496-2 Ed. 2 “ Safety of machinery - Electro-sensitive protective equipment- General requirements and tests”
- EN ISO 13849-1 “Safety of machinery – Safety-related parts of control systems – Part 1: General principles for design”
- IEC/EN 62061 “Safety of machinery – Functional safety of safety-related electrical, electronic and programmable electronic control systems”
- IEC 61508 “Functional safety of electrical/electronic/programmable electronic safety-related systems”
- IEC/TS 62046 Ed. 2 “Safety of machinery – Application of protective equipment to detect the presence of persons”
- UL (C+US) mark for USA and Canada
- ANSI / UL 1998 “Safety Software in Programmable Components”.



### THE VISION RANGE

VISION V L	VISION V H	VISION VX	VISION VX LR Long Range	VISION VX M - S	VISION VXL	VISION MXL See following table
Max. range 6 m	Max. range 16 m	Max. range selectable 6 or 18 m	Max. range selectable 22 or 60 m	Master and Slave models for serial connection of two light curtains even of different height and resolution	Max. range 8 m	Built-in Muting function with 2 sensors operating logic
The ideal Type 2 safety light curtain for a simple interface with safety modules or PLC		The ideal Type 2 safety light curtain for directly control- ling and monitoring the circuits of the machine, without the need for external safety modules	The ideal safety light curtain for protection applications with a long range, also on several sides using deflection mirrors	Ideal solution for con- necting two light curtains in series and constituting a combined detection of the hand and of the presence of a person or of two different sides of the machine	Similar to the VX models but available in a limited number of versions; especially conceived to satisfy the most frequent application needing at a very competitive price	Can offer a complete range of essential functions and satisfy the most common application needs where the Muting function is required, together with a very competitive price
Types of detection: resolution 20, 30, 40 mm for hand detection resolution 50, 90 mm for detection of the body in a hazardous area 2, 3, 4 beams for detection of the body in access control			Types of detection: 2, 3, 4 beams for detection of the body in access monitoring	Types of detection: resolution 30, 40, 50 mm for hand detection 2, 3 beams for detection of the body in access control	Types of detection: resolution 30, 40 mm for hand detection 2, 3, 4 beams for detection of the body in access control	
Electrical connections: M12 5-pole connectors		Electrical connections: M12 5-pole connectors for emitter and M12 8-pole connectors for receiver				Electrical connections: M12 5-pole connectors for emitter and M16 12-pole connectors for receiver
Automatic Start/Restart		Built-in manual or automatic Start/Restart selectable				
External relay monitoring (EDM) through external AD SR1 interface		Feedback input for control of external relays (EDM)				
2 self-testing solid state PNP safety outputs protected against short circuits and overloads						

### THE VISION MXL RANGE

 <p><b>MXL SERIES</b></p>	<p><b>MXL and MXL U SERIES</b></p> <p>Both have two dedicated inputs on the M16 connector for connection of external Muting sensors of any type such as photocells, proximity switches, limit switches, etc.</p>	<p><b>MXL</b></p> <p>The MXL series is recommended for Muting applications:</p> <ul style="list-style-type: none"> <li>• Where personnel is supposed to access the area under control during the non-dangerous part of the machine cycle (e. g. manual load/unload of product).</li> <li>• For two-way transit of material through the gate to be controlled by the light curtain (e.g. palletizers).</li> </ul>
		<p><b>MXL U</b></p> <p>Only for muting applications where one-way transit (exit only) of material through the gate is controlled by the light curtain (e.g. palletizers).</p>
 <p><b>MXL L SERIES</b></p>	<p><b>MXL L SERIES</b></p> <p>The MXL L series, with 2 or 3 beams for access control, uses an original system of 2 horizontal arms (one for the emitter and one for the receiver) with built-in, pre-wired and pre-aligned photoelectric Muting sensors. The arms can be adjusted in height and angle in order to create a detection plane that is more or less angled, with the purpose to achieve correct and constant detection of the material in transit and therefore reliable operation of the protection system. This ensures the maximum speed and simplicity of installation. The MXL L series manages the Muting function in one-way mode and is particularly suitable for protecting the outfeed gates of palletizing systems.</p>	
 <p><b>MXL T SERIES</b></p>	<p><b>MXL T SERIES</b></p> <p>The MXL T series, with 2 or 3 beams for access control, features four horizontal arms (two for the emitter and two for the receiver) with built-in, pre-wired and pre-aligned photoelectric Muting sensors. The arms can be adjusted in height and angle in order to create a detection plane that is more or less angled, with the purpose to achieve correct and constant detection of the material in transit and therefore reliable operation of the protection system. This ensures the maximum speed and simplicity of installation. The MXL T series manages the Muting function in two-way mode for the protection of the infeed/outfeed gates in palletizing systems.</p>	



# VISION V

## MAIN FEATURES

- Automatic start/restart.
- Two self-testing solid state PNP safety outputs.
- Periodic auto-test every 0.5 sec.
- All connections and configuration by means of M12 connectors.
- Use of unshielded cables up to 100 m.
- Suppression of optical interference by means of range selection.
- Start/Restart interlock and EDM via external AD SR1 interface.

## TECHNICAL FEATURES

<b>Safety level</b>	Type 2 according to IEC/TS 61496-2 SIL 2 – SILCL 2 according to IEC 61508 - IEC 62061 PL d – Cat. 2 according to ISO 13849-1
<b>Protected heights (mm)</b>	160 ... 1810
<b>Resolutions (mm)</b>	20, 30, 40, 50, 90
<b>Number of beams for body detection in access control</b>	2, 3, 4
<b>Max. range (m)</b>	6 for Vision V L models 16 for Vision V H models
<b>Response time (ms)</b>	5,5 ... 28
<b>Safety outputs</b>	2 PNP auto-controlled - 500 mA at 24 VDC with short-circuit, overload, polarity reversal protection
<b>Signalling</b>	LEDs for light curtain's status and diagnostic
<b>Restart</b>	automatic
<b>Power supply (VDC)</b>	24 ± 20%
<b>Electrical connections</b>	M12 5-pole
<b>Max. cable length (m)</b>	100
<b>Operating temperature (°C)</b>	0 ... 55
<b>Protection rating</b>	IP 65
<b>Fastening modes</b>	back slot, side slot or to the top and lower end with swivel brackets
<b>Cross section (mm)</b>	35 x 45



Emitter - 5 poles

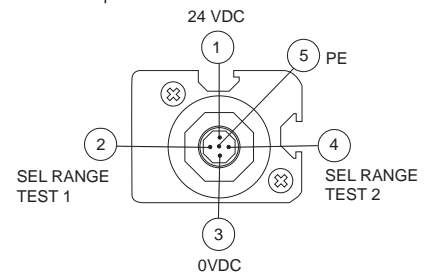

Receiver - 5 poles

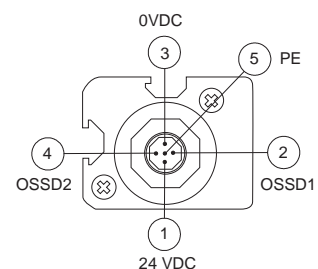

Safety level:

**TYPE 2**

**SIL 2 – SILCL 2  
PL d – Cat. 2**





**Models L - Max. range: 6 m**

**Models H - Max. range: 16 m**

	Resolution 20 mm	V 152L	V 302L	V 452L	V 602L	V 752L	V 902L	V 1052L	V 1202L	V 1352L	V 1502L	V 1652L	V 1802L
 Ordering codes		<b>1340100</b>	<b>1340101</b>	<b>1340102</b>	<b>1340103</b>	<b>1340104</b>	<b>1340105</b>	<b>1340106</b>	<b>1340107</b>	<b>1340108</b>	<b>1340109</b>	<b>1340110</b>	<b>1340111</b>
	Resolution 20 mm	V 152H	V 302H	V 452H	V 602H	V 752H	V 902H	V 1052H	V 1202H	V 1352H	V 1502H	V 1652H	V 1802H
Ordering codes		<b>1340120</b>	<b>1340121</b>	<b>1340122</b>	<b>1340123</b>	<b>1340124</b>	<b>1340125</b>	<b>1340126</b>	<b>1340127</b>	<b>1340128</b>	<b>1340129</b>	<b>1340130</b>	<b>1340131</b>
Protected height (mm)		160	310	460	610	760	910	1060	1210	1360	1510	1660	1810
Number of beams		15	30	45	60	75	90	105	120	135	150	165	180
Overall height (mm)		261	411	561	711	861	1011	1161	1311	1461	1611	1761	1911

	Resolution 30 mm	V 153L	V 303L	V 453L	V 603L	V 753L	V 903L	V 1053L	V 1203L	V 1353L	V 1503L	V 1653L	V 1803L
 Ordering codes		<b>1340200</b>	<b>1340201</b>	<b>1340202</b>	<b>1340203</b>	<b>1340204</b>	<b>1340205</b>	<b>1340206</b>	<b>1340207</b>	<b>1340208</b>	<b>1340209</b>	<b>1340210</b>	<b>1340211</b>
	Resolution 30 mm	V 153H	V 303H	V 453H	V 603H	V 753H	V 903H	V 1053H	V 1203H	V 1353H	V 1503H	V 1653H	V 1803H
Ordering codes		<b>1340220</b>	<b>1340221</b>	<b>1340222</b>	<b>1340223</b>	<b>1340224</b>	<b>1340225</b>	<b>1340226</b>	<b>1340227</b>	<b>1340228</b>	<b>1340229</b>	<b>1340230</b>	<b>1340231</b>
Protected height (mm)		160	310	460	610	760	910	1060	1210	1360	1510	1660	1810
Number of beams		8	16	24	32	40	48	56	64	72	80	88	96
Overall height (mm)		261	411	561	711	861	1011	1161	1311	1461	1611	1761	1911

	Resolution 40 mm	V 304L	V 454L	V 604L	V 754L	V 904L	V 1054L	V 1204L	V 1354L	V 1504L	V 1654L	V 1804L
 Ordering codes		<b>1340301</b>	<b>1340302</b>	<b>1340303</b>	<b>1340304</b>	<b>1340305</b>	<b>1340306</b>	<b>1340307</b>	<b>1340308</b>	<b>1340309</b>	<b>1340310</b>	<b>1340311</b>
	Resolution 40 mm	V 304H	V 454H	V 604H	V 754H	V 904H	V 1054H	V 1204H	V 1354H	V 1504H	V 1654H	V 1804H
Ordering codes		<b>1340321</b>	<b>1340322</b>	<b>1340323</b>	<b>1340324</b>	<b>1340325</b>	<b>1340326</b>	<b>1340327</b>	<b>1340328</b>	<b>1340329</b>	<b>1340330</b>	<b>1340331</b>
Protected height (mm)		310	460	610	760	910	1060	1210	1360	1510	1660	1810
Number of beams		10	15	20	25	30	35	40	45	50	55	60
Overall height (mm)		411	561	711	861	1011	1161	1311	1461	1611	1761	1911

	Resolution 50 mm	V 305L	V 455L	V 605L	V 755L	V 905L	V 1055L	V 1205L	V 1355L	V 1505L	V 1655L	V 1805L
 Ordering codes		<b>1340401</b>	<b>1340402</b>	<b>1340403</b>	<b>1340404</b>	<b>1340405</b>	<b>1340406</b>	<b>1340407</b>	<b>1340408</b>	<b>1340409</b>	<b>1340410</b>	<b>1340411</b>
	Resolution 50 mm	V 305H	V 455H	V 605H	V 755H	V 905H	V 1055H	V 1205H	V 1355H	V 1505H	V 1655H	V 1805H
Ordering codes		<b>1340421</b>	<b>1340422</b>	<b>1340423</b>	<b>1340424</b>	<b>1340425</b>	<b>1340426</b>	<b>1340427</b>	<b>1340428</b>	<b>1340429</b>	<b>1340430</b>	<b>1340431</b>
Protected height (mm)		310	460	610	760	910	1060	1210	1360	1510	1660	1810
Number of beams		8	12	16	20	24	28	32	36	40	44	48
Overall height (mm)		411	561	711	861	1011	1161	1311	1461	1611	1761	1911

	Resolution 90 mm	V 309L	V 459L	V 609L	V 759L	V 909L	V 1059L	V 1209L	V 1359L	V 1509L	V 1659L	V 1809L
 Ordering codes		<b>1340501</b>	<b>1340502</b>	<b>1340503</b>	<b>1340504</b>	<b>1340505</b>	<b>1340506</b>	<b>1340507</b>	<b>1340508</b>	<b>1340509</b>	<b>1340510</b>	<b>1340511</b>
	Resolution 90 mm	V 309H	V 459H	V 609H	V 759H	V 909H	V 1059H	V 1209H	V 1359H	V 1509H	V 1659L	V 1809L
Ordering codes		<b>1340521</b>	<b>1340522</b>	<b>1340523</b>	<b>1340524</b>	<b>1340525</b>	<b>1340526</b>	<b>1340527</b>	<b>1340528</b>	<b>1340529</b>	<b>1340530</b>	<b>1340531</b>
Protected height (mm)		310	460	610	760	910	1060	1210	1360	1510	1660	1810
Number of beams		5	7	9	11	13	15	17	19	21	23	25
Overall height (mm)		411	561	711	861	1011	1161	1311	1461	1611	1761	1911

	2, 3, 4 beams	V 2B L	V 3B L	V 4B L
 Ordering codes		<b>1340600</b>	<b>1340601</b>	<b>1340602</b>
	2, 3, 4 beams	V 2B H	V 3B H	V 4B H
Ordering codes		<b>1340610</b>	<b>1340611</b>	<b>1340612</b>
Number of beams		2	3	4
Beam spacing (mm)		500	400	300
Protected height (mm)		510	810	910
Overall height (mm)		711	1011	1111

► "ACCESSORIES" on page 153

# VISION VX

## WITH BUILT-IN CONTROL FUNCTIONS

### MAIN FEATURES

- Two self-testing solid state PNP safety outputs.
- Periodic auto-test every 0.5 sec.
- Built-in Start/Restart interlock, selectable.
- Feedback input for control of external relays (EDM).
- All connections and configuration by means of M12 connectors.
- Use of unshielded cables up to 100 m.
- Suppression of optical interference by means of range selection.
- Master and Slave models for serial connection of 2 light curtains.
- Maximum length of the connections between Master and Slave: 50 metres, with unshielded cable.
- Models with 2, 3 and 4 beams Long Range, max. 60 meters.

### TECHNICAL FEATURES

<b>Safety level</b>	Type 2 according to IEC/TS 61496-2 SIL 2 – SILCL 2 according to IEC 61508 - IEC 62061 PL d – Cat. 2 according to ISO 13849-1
<b>Protected heights (mm)</b>	160 ... 1810
<b>Resolutions (mm)</b>	20, 30, 40, 50, 90
<b>Number of beams for body detection in access control</b>	2, 3, 4
<b>Max. range (m)</b>	selectable 6 or 18 selectable 22 or 60 for 2, 3, 4 beams Long Range
<b>Response time (ms)</b>	5,5 ... 28
<b>Safety outputs</b>	2 PNP auto-controlled - 500 mA at 24 VDC with short-circuit, overload, polarity reversal protection
<b>Signalling</b>	seven-segment display and LEDs for light curtain's status and diagnostic
<b>Start/Restart</b>	automatic or manual, selectable
<b>External Device Monitoring</b>	feedback input
<b>Power supply (VDC)</b>	24 ± 20%
<b>Electrical connections for VX and VX Master</b>	M12 5-pole for emitter M12 8-pole for receiver
<b>Electrical connections between Master and Slave</b>	M12 5-pole for emitter and receiver
<b>Max. cable length (m)</b>	100 (50 between master and slave)
<b>Operating temperature (°C)</b>	0 ... 55
<b>Protection rating</b>	IP 65
<b>Fastening modes</b>	back slot, side slot or to the top and lower end with swivel brackets
<b>Cross section (mm)</b>	35 x 45



Emitter - 5 poles

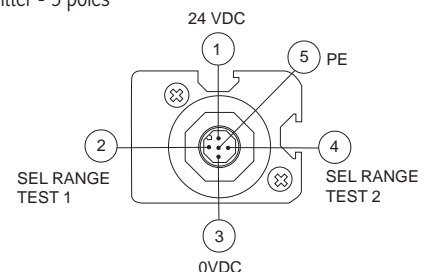

Receiver - 8 poles

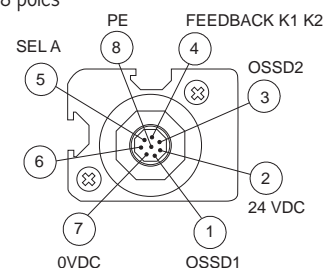

Safety level

**TYPE 2**

**SIL 2 – SILCL 2**  
**PL d – Cat. 2**

## VISION VX WITH BUILT-IN CONTROL FUNCTIONS

Models with max. range: selectable 6 m or 18 m



Resolution 20 mm	VX 152	VX 302	VX 452	VX 602	VX 752	VX 902	VX 1052	VX 1202	VX 1352	VX 1502	VX 1652	VX 1802
Ordering codes	1344100	1344101	1344102	1344103	1344104	1344105	1344106	1344107	1344108	1344109	1344110	1344111
Protected height (mm)	160	310	460	610	760	910	1060	1210	1360	1510	1660	1810
Number of beams	15	30	45	60	75	90	105	120	135	150	165	180
Overall height (mm)	261	411	561	711	861	1011	1161	1311	1461	1611	1761	1911



Resolution 30 mm	VX 153	VX 303	VX 453	VX 603	VX 753	VX 903	VX 1053	VX 1203	VX 1353	VX 1503	VX 1653	VX 1803
Ordering codes	1344200	1344201	1344202	1344203	1344204	1344205	1344206	1344207	1344208	1344209	1344210	1344211
Protected height (mm)	160	310	460	610	760	910	1060	1210	1360	1510	1660	1810
Number of beams	8	16	24	32	40	48	56	64	72	80	88	96
Overall height (mm)	261	411	561	711	861	1011	1161	1311	1461	1611	1761	1911



Resolution 40 mm	VX 304	VX 454	VX 604	VX 754	VX 904	VX 1054	VX 1204	VX 1354	VX 1504	VX 1654	VX 1804
Ordering codes	1344301	1344302	1344303	1344304	1344305	1344306	1344307	1344308	1344309	1344310	1344311
Protected height (mm)	310	460	610	760	910	1060	1210	1360	1510	1660	1810
Number of beams	10	15	20	25	30	35	40	45	50	55	60
Overall height (mm)	411	561	711	861	1011	1161	1311	1461	1611	1761	1911



Resolution 50 mm	VX 305	VX 455	VX 605	VX 755	VX 905	VX 1055	VX 1205	VX 1355	VX 1505	VX 1655	VX 1805
Ordering codes	1344401	1344402	1344403	1344404	1344405	1344406	1344407	1344408	1344408	1344410	1344411
Protected height (mm)	310	460	610	760	910	1060	1210	1360	1510	1660	1810
Number of beams	8	12	16	20	24	28	32	36	40	44	48
Overall height (mm)	411	561	711	861	1011	1161	1311	1461	1611	1761	1911



Resolution 90 mm	VX 309	VX 459	VX 609	VX 759	VX 909	VX 1059	VX 1209	VX 1359	VX 1509	VX 1659	VX 1809
Ordering codes	1344501	1344502	1344503	1344504	1344505	1344506	1344507	1344508	1344509	1344510	1344511
Protected height (mm)	310	460	610	760	910	1060	1210	1360	1510	1660	1810
Number of beams	5	7	9	11	13	15	17	19	21	23	25
Overall height (mm)	411	561	711	861	1011	1161	1311	1461	1611	1761	1911

Models LR - Max range: selectable 22 m or 60 m



2, 3, 4 beams	VX 2B	VX 3B	VX 4B	VX* 2B LR	VX* 3B LR	VX* 4B LR
Ordering codes	1344600	1344601	1344602	1344603	1344604	1344605
Number of beams	2	3	4	2	3	4
Beam spacing (mm)	500	400	300	500	400	300
Protected height (mm)	510	810	910	510	810	910
Overall height (mm)	711	1011	1111	711	1011	1111

\* Range 60 m

► "ACCESSORIES" on page 153

# VISION VX WITH BUILT-IN CONTROL FUNCTIONS

## MASTER/SLAVE MODELS

Master/Slave models permit series connection of two safety light curtains achieving two main advantages:  
a single pair of safety outputs;  
no interference between light curtains installed adjacent to one another.

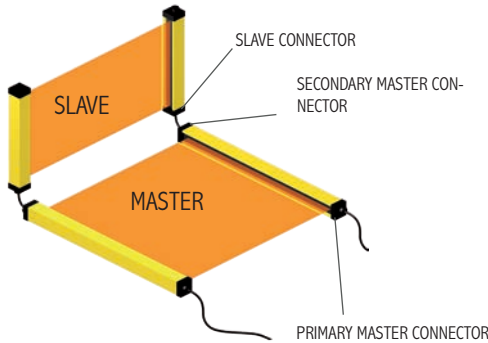

### EXAMPLE OF SERIAL CONNECTION BETWEEN MASTER AND SLAVE LIGHT CURTAINS

It is possible to combine any Master model with any Slave model.

All the electrical connections are made using 5-pole M12 connectors, except for the Master receiver, which requires an 8-pole M12 connector.

Pre-wired cables with 2 connectors are available for the connection between Master and Slave.

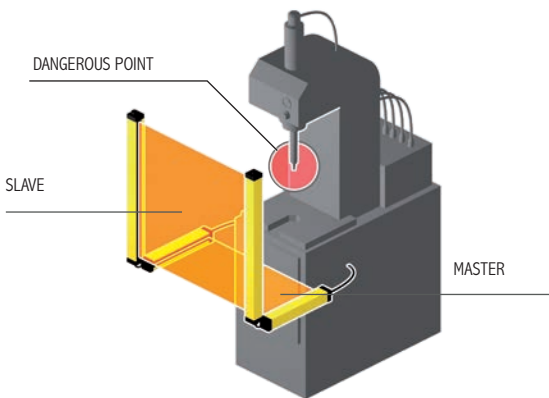

### EXAMPLE OF SERIAL CONNECTION BETWEEN MASTER AND SLAVE LIGHT CURTAINS

The Master light curtain is positioned horizontally for detecting the presence of the person while the vertical Slave light curtain detects finger or hand.

However, it is possible to invert the combination and have the Master light curtain positioned vertically for hand protection and the Slave light curtain horizontally for detecting the presence of the person.

The application illustrated is one of the most common: the horizontal light curtain is used for eliminating the possibility for the operator not to be detected between the vertical light curtain and the dangerous machine at the start or restart of the system.

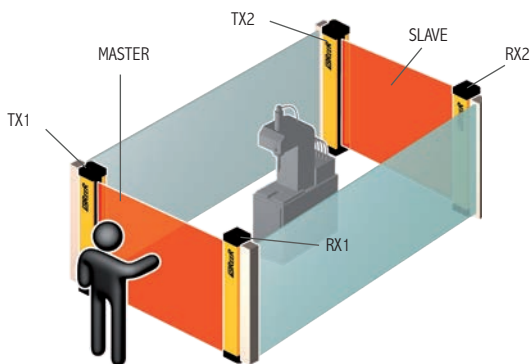

### EXAMPLE OF SERIAL CONNECTION BETWEEN MASTER AND SLAVE LIGHT CURTAINS FOR THE PROTECTION OF 2 SIDES OF THE MACHINE

In the Vision VX light curtains, the length of the connection cable between Master and Slave can be up to 50 metres.

This characteristic enables the application of 2 light curtains in series positioned on the front and back of the dangerous machine, with a single connection towards the power supply and control circuits of the machine.

## VISION VX WITH BUILT-IN CONTROL FUNCTIONS

### MASTER/SLAVE models with max. range: selectable 6 m or 18 m



<b>MASTER</b> Resolution 30 mm	<b>VX</b> 153M	<b>VX</b> 303M	<b>VX</b> 453M	<b>VX</b> 603M	<b>VX</b> 753M	<b>VX</b> 903M	<b>VX</b> 1053M	<b>VX</b> 1203M	<b>VX</b> 1503M
Ordering codes	<b>1344220</b>	<b>1344221</b>	<b>1344222</b>	<b>1344223</b>	<b>1344224</b>	<b>1344225</b>	<b>1344226</b>	<b>1344227</b>	<b>1344229</b>
<b>SLAVE</b> Resolution 30 mm	<b>VX</b> 153S	<b>VX</b> 303S	<b>VX</b> 453S	<b>VX</b> 603S	<b>VX</b> 753S	<b>VX</b> 903S	<b>VX</b> 1053S	<b>VX</b> 1203S	<b>VX</b> 1503S
Ordering codes	<b>1344240</b>	<b>1344241</b>	<b>1344242</b>	<b>1344243</b>	<b>1344244</b>	<b>1344245</b>	<b>1344246</b>	<b>1344247</b>	<b>1344249</b>
Protected height (mm)	160	310	460	610	760	910	1060	1210	1510
Number of beams	8	16	24	32	40	48	56	64	80
Overall height (mm) *	261	411	561	711	861	1011	1161	1311	1611



<b>MASTER</b> Resolution 40 mm	<b>VX</b> 304M	<b>VX</b> 454M	<b>VX</b> 604M	<b>VX</b> 754M	<b>VX</b> 904M	<b>VX</b> 1054M	<b>VX</b> 1204M	<b>VX</b> 1504M
Ordering codes	<b>1344321</b>	<b>1344322</b>	<b>1344323</b>	<b>1344324</b>	<b>1344325</b>	<b>1344326</b>	<b>1344327</b>	<b>1344329</b>
<b>SLAVE</b> Resolution 40 mm	<b>VX</b> 304S	<b>VX</b> 454S	<b>VX</b> 604S	<b>VX</b> 754S	<b>VX</b> 904S	<b>VX</b> 1054S	<b>VX</b> 1204S	<b>VX</b> 1504S
Ordering codes	<b>1344341</b>	<b>1344342</b>	<b>1344343</b>	<b>1344344</b>	<b>1344345</b>	<b>1344346</b>	<b>1344347</b>	<b>1344349</b>
Protected height (mm)	310	460	610	760	910	1060	1210	1510
Number of beams	10	15	20	25	30	35	40	50
Overall height (mm) *	411	561	711	861	1011	1161	1311	1611



<b>MASTER</b> Resolution 50 mm	<b>VX</b> 305M	<b>VX</b> 455M	<b>VX</b> 605M	<b>VX</b> 755M	<b>VX</b> 905M	<b>VX</b> 1055M	<b>VX</b> 1205M	<b>VX</b> 1505M
Ordering codes	<b>1344421</b>	<b>1344422</b>	<b>1344423</b>	<b>1344424</b>	<b>1344425</b>	<b>1344426</b>	<b>1344427</b>	<b>1344429</b>
<b>SLAVE</b> Resolution 50 mm	<b>VX</b> 305S	<b>VX</b> 455S	<b>VX</b> 605S	<b>VX</b> 755S	<b>VX</b> 905S	<b>VX</b> 1055S	<b>VX</b> 1205S	<b>VX</b> 1505S
Ordering codes	<b>1344441</b>	<b>1344442</b>	<b>1344443</b>	<b>1344444</b>	<b>1344445</b>	<b>1344446</b>	<b>1344447</b>	<b>1344449</b>
Protected height (mm)	310	460	610	760	910	1060	1210	1510
Number of beams	8	12	16	20	24	28	32	40
Overall height (mm) *	411	561	711	861	1011	1161	1311	1611



<b>MASTER</b> 2, 3 beams	<b>VX</b> 2BM	<b>VX</b> 3BM
Ordering codes	<b>1344620</b>	<b>1344621</b>
<b>SLAVE</b> 2, 3 beams	<b>VX</b> 2BS	<b>VX</b> 3BS
Ordering codes	<b>1344640</b>	<b>1344641</b>
Number of beams	2	3
Beam spacing (mm)	500	400
Protected height (mm)	510	810
Overall height (mm) *	711	1011

\* Overall height is referred to the slave model.

In the Master models, the total light curtain height is increased by 10 mm due to the presence of the secondary connector.

► **"ACCESSORIES" on page 154**

# VISION VXL WITH BUILT-IN CONTROL FUNCTIONS

## MAIN FEATURES

- Built-in Start/Restart interlock, selectable.
- Two self-testing solid state PNP safety outputs.
- Periodic auto-test every 0,5 sec.
- Feedback input for control of external relays (EDM).
- All connections and configuration by means of M12 connectors.
- Use of unshielded cables up to 100 m.

## TECHNICAL FEATURES

<b>Safety level</b>	Type 2 according to IEC/TS 61496-2 SIL 2 – SILCL 2 according to IEC 61508 - IEC 62061 PL d – Cat. 2 according to ISO 13849-1
<b>Protected heights (mm)</b>	160 ... 1810
<b>Resolutions (mm)</b>	30, 40
<b>Number of beams for body detection in access control</b>	2, 3, 4
<b>Max. range (m)</b>	8
<b>Response time (ms)</b>	2 ... 25
<b>Safety outputs</b>	2 PNP - 500 mA at 24 VDC with short-circuit, overload, polarity reversal protection
<b>Signalling</b>	LEDs for light curtain's status and diagnostic
<b>Start/Restart</b>	automatic or manual, selectable
<b>External Device Monitoring</b>	feedback input
<b>Power supply (VDC)</b>	24 ± 20%
<b>Electrical connections</b>	M12 5-pole for emitter M12 8-pole for receiver
<b>Max. cable length (m)</b>	100
<b>Operating temperature (°C)</b>	0 ... 55
<b>Protection rating</b>	IP 65
<b>Fastening modes</b>	back slot, side slot or to the top and lower end with swivel brackets
<b>Cross section (mm)</b>	35 x 45



Emitter - 5 poles

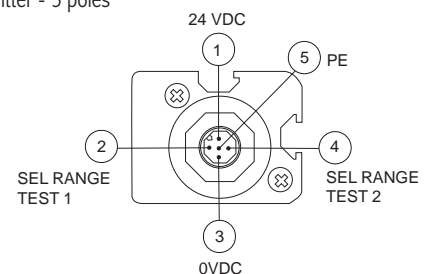

Receiver - 8 poles

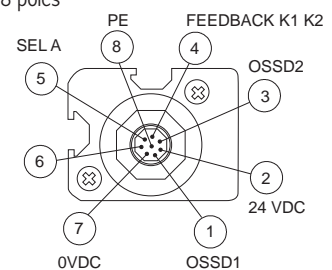

Safety level:

**TYPE 2**

**SIL 2 – SILCL 2  
PL d – Cat. 2**



## VISION VXL WITH BUILT-IN CONTROL FUNCTIONS

### Models with max. range: 8 m



Resolution 30 mm	VXL 153	VXL 303	VXL 453	VXL 603	VXL 753	VXL 903	VXL 1053	VXL 1203
Ordering codes	<b>1344700</b>	<b>1344701</b>	<b>1344702</b>	<b>1344703</b>	<b>1344704</b>	<b>1344705</b>	<b>1344706</b>	<b>1344707</b>
Protected height (mm)	160	310	460	610	760	910	1060	1210
Number of beams	8	16	24	32	40	48	56	64
Overall height (mm)	261	411	561	711	861	1011	1161	1311



Resolution 40 mm	VXL 304	VXL 454	VXL 604	VXL 754	VXL 904	VXL 1054	VXL 1204	VXL 1354	VXL 1504	VXL 1654	VXL 1804
Ordering codes	<b>1344711</b>	<b>1344712</b>	<b>1344713</b>	<b>1344714</b>	<b>1344715</b>	<b>1344716</b>	<b>1344717</b>	<b>1344723</b>	<b>1344719</b>	<b>1344724</b>	<b>1344725</b>
Protected height (mm)	310	460	610	760	910	1060	1210	1360	1510	1660	1810
Number of beams	10	15	20	25	30	35	40	45	50	55	60
Overall height (mm)	411	561	711	861	1011	1161	1311	1461	1611	1761	1911



2, 3, 4 beams	VXL 2B	VXL 3B	VXL 4B
Ordering codes	<b>1344720</b>	<b>1344721</b>	<b>1344722</b>
Number of beams	2	3	4
Beam spacing (mm)	500	400	300
Protected height (mm)	510	810	910
Overall height (mm)	711	1011	1111

► "ACCESSORIES" on page 153



VISION MXL

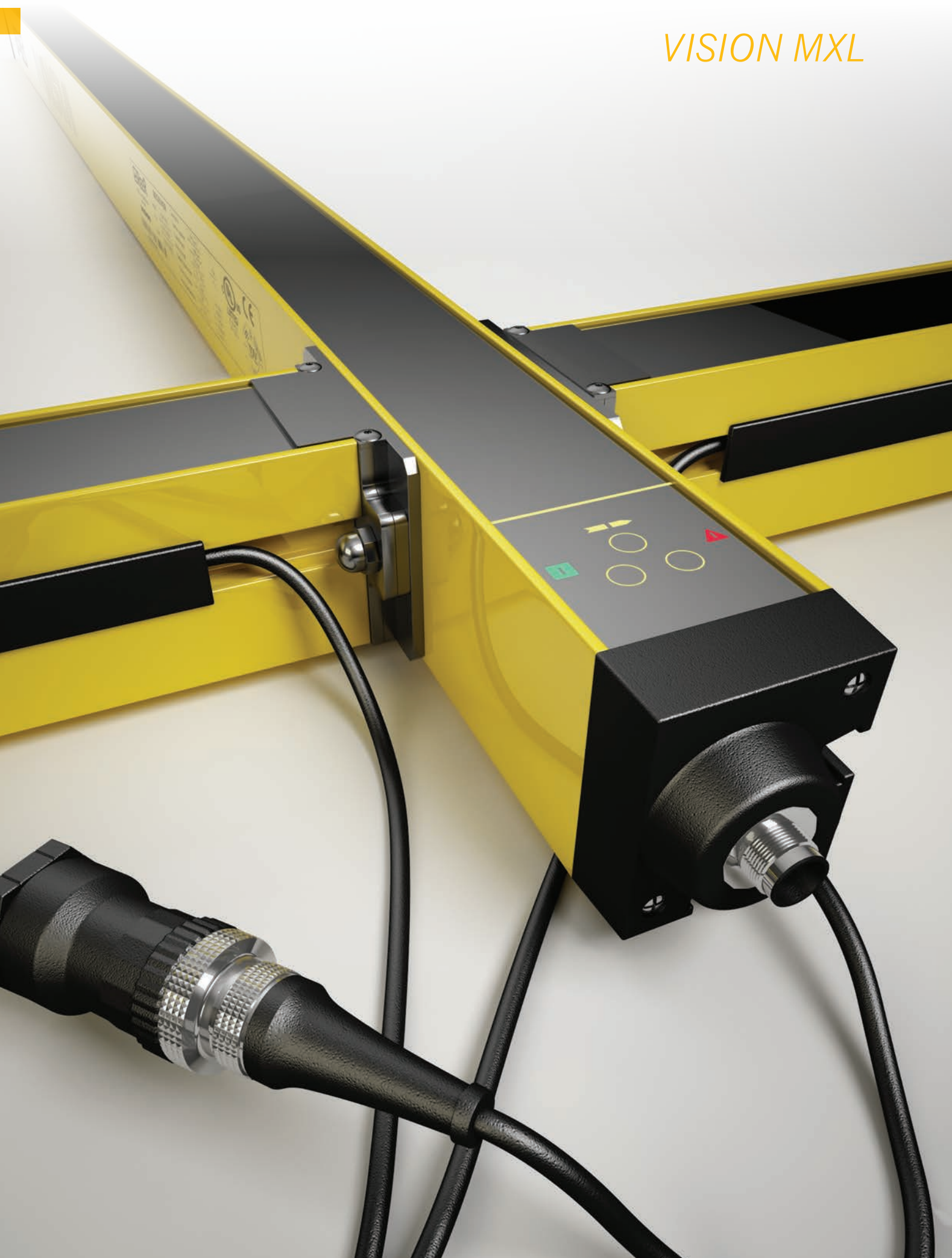

## VISION MXL WITH MUTING FUNCTION

Vision MXL is a range of safety light curtains for the protection of dangerous systems with Muting function. Models MXL L and MXL T are available with integrated Muting sensors.

MXL features include the following:

- Extremely easy connection and installation, through the use of standard connectors and unshielded cables up to 100 m
- Integration of the main safety functions including auto-control of static outputs, control of external contactors (EDM) and Start/Restart interlock
- Integrated auto-test, activated automatically and periodically, without discontinuity to the operation of the machine being controlled
- Integrated Muting function and Muting sensors on models MXL L and MXL T
- Set-up of each function can be done through main connector. No need of software configuration
- Excellent field reliability, assured by robust construction and high-level immunity from external interference (optical, EMC, etc.)
- Comprehensive range, offering outstanding cost effectiveness.

For Vision MXL light curtains is available a range of specific accessories including pre-wired cable and MXJB Connection Boxes, complete with Restart and Override controls, plus Muting lamp and integrated safety relays for straightforward, quick and reliable interfacing of the safety light curtains with the machine being controlled.

### MAIN FEATURES

Integrated Muting function with two-sensors bi-directional or mono-directional logic.  
High flexibility in terms of interface configurations, Muting logics and time-out.  
Selectable overrides (two types).

Muting enable input.

Each configuration is implemented via hardware through main M16 12-pole connector.  
No need for software configuration via PC.

Unshielded cables up to 100 m.

Two safety PNP static outputs, auto-controlled.

Periodic auto-test every 0.5 sec.

Integrated selectable Start/Restart interlock.

Feedback input for controlling external relays (EDM).

Models MXL L and MXL T with integrated Muting sensors, pre-aligned, adjustable for height and angle.

Interconnection box MXJB for quick connection of light curtains and availability of the main controls needed for operation close to the gate to be protected.



### Safety level: Type 2 – SIL 2 – SILCL 2 – PL d – Cat. 2

- 2006/42/EC "Machinery Directive"
- 2004/108/EC " Electromagnetic Compatibility (EMC)"
- 2006/95/EC "Low Voltage Directive (LVD)"
- IEC/EN 61496-1 Ed. 2.1, IEC/TS 61496-2 Ed. 2 " Safety of machinery - Electro-sensitive protective equipment- General requirements and tests"
- EN ISO 13849-1 "Safety of machinery – Safety-related parts of control systems – Part 1: General principles for design"
- IEC/EN 62061 "Safety of machinery – Functional safety of safety-related electrical, electronic and programmable electronic control systems"
- IEC 61508 "Functional safety of electrical/electronic/programmable electronic safety-related systems"
- IEC/TS 62046 Ed. 2 "Safety of machinery – Application of protective equipment to detect the presence of persons"
- UL (C+US) mark for USA and Canada
- ANSI / UL 1998 "Safety Software in Programmable Components".



## VISION MXL WITH MUTING FUNCTION

**Vision MXL offer a cost-effective solution for the most common palletized applications.**

**With the MXL L and MXL T models, system installation is fast and simple; moreover, compliance with the standards requirements regarding the geometry of the Muting sensors and all the other safety parameters is guaranteed (IEC/TS 62046)**

### MXL

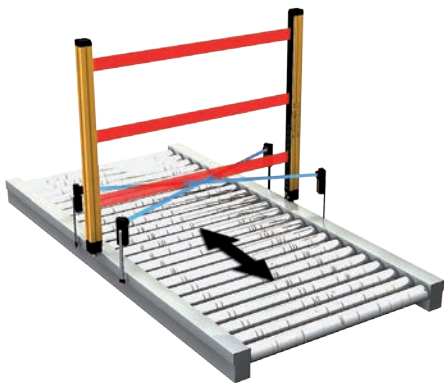

#### Two-way Muting with 2 sensors. Entry/Exit

- Max. time between the 2 Muting activation signals: 4 sec.
- Possible use with any type of external Muting sensors such as photocells, proximity switches, limit switches, etc.
- Muting Time-out 30 sec, 90 min or infinite, selectable.
- Muting Enable input.

#### Characteristics

- Suitable solution for the most common entry/exit pallet applications.
- Muting enable input allows to start a Muting sequence only when needed by the machine cycle. I.e. Muting enabled only when the conveyor is moving.

MXL series is recommended also in those applications where personnel is allowed to access the monitored area during the non-dangerous part of the machine cycle. (i.e. manual material loading/unloading). [See page 39.](#)

### MXL U



#### One-way Muting with 2 sensors – Exit only

- Max. time between the 2 Muting activation signals: 4 sec.
- Possible use with any type of external Muting sensors such as photocells, proximity switches, limit switches, etc.
- Muting Time-out 30 sec, 90 min or infinite, selectable.
- Muting Enable input.

#### Characteristics

- The light curtain only allows pallet outfeed.
- The Muting function can only be activated from inside the protected zone. No possibility to activate a Muting sequence from the outside.
- Elimination of bulk outside the protected area, as the Muting sensors are only present inside the area.
- Correct Muting sequence even in the presence of a pallet with reduced width and/or length or not centred with respect to the conveyor.
- Muting enable input allows to start a Muting sequence only when needed by the machine cycle. I.e. Muting enabled only when the conveyor is moving.

Safety level

**TYPE 2**

**SIL 2 – SILCL 2  
PL d – Cat. 2**



### MXL L

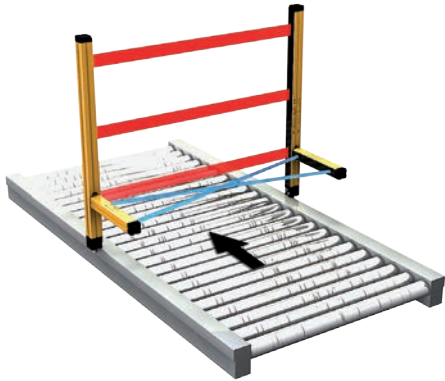

#### One-way Muting with 2 sensors – Exit only 2 integrated photoelectric sensors with crossed beams

- 2, 3 beams models.
- Max. time between the 2 Muting activation signals: 4 sec.
- Operating range: 1 ... 2,5 meters.
- Muting sensor elements adjustable in height and angle.
- Muting Time-out 30 sec, 90 min or infinite, selectable.
- Muting Enable input.

#### Characteristics

- Reduced installation time and costs.
- With MXL L models, sensors are positioned in compliance with the regulations regarding the geometry of Muting sensors (IEC TS 62046) and all the other safety parameters; this makes it possible to avoid dangers arising from positioning errors and from possible tampering.
- The light curtain only allows pallet outfeed.
- The Muting function can only be activated from inside the protected zone. No possibility to activate a Muting sequence from the outside.
- Elimination of bulk outside the protected area, as the Muting sensors are only present inside the area.
- Correct Muting sequence even in the presence of a pallet with reduced width and/or length or not centred with respect to the conveyor.
- Muting enable input allows to start a Muting sequence only when needed by the machine cycle. I.e. Muting enabled only when the conveyor is moving.

### MXL T



#### Two-way Muting with 2 sensors – Entry/Exit 2 integrated photoelectric sensors with crossed beams

- 2, 3 beams models.
- Max. time between the 2 Muting activation signals: 4 sec.
- Operating range: 1 ... 2,5 meters.
- Muting sensor elements adjustable in height and angle.
- Muting Time-out 30 sec, 90 min or infinite, selectable.
- Muting Enable input.

#### Characteristics

- Reduced installation time and costs.
- With MXL T models, sensors are positioned in compliance with the regulations regarding the geometry of Muting sensors (IEC TS 62046) and all the other safety parameters; this makes it possible to avoid dangers arising from positioning errors and from possible tampering.
- Standard solution for the most common entry/exit pallet applications.
- Muting enable input allows to start a Muting sequence only when needed by the machine cycle. I.e. Muting enabled only when the conveyor is moving.

## VISION MXL

### WITH MUTING FUNCTION

#### GENERAL TECHNICAL DATA

<b>Safety level</b>	Type 2 according to IEC/TS 61496-2 SIL 2 – SILCL 2 according to IEC 61508 - IEC 62061 PL d – Cat. 2 according to ISO 13849-1
<b>Response time (ms)</b>	4 ... 37
<b>Safety outputs</b>	2 PNP auto-controlled– 500 mA at 24 VDC with short-circuit, overload, polarity reversal protection
<b>Muting lamp output</b>	24 VDC - 0,5 ... 5 W
<b>Muting enable input</b>	0 or 24 VDC (active high)
<b>Signalling</b>	LEDs for light curtain's and Muting sensors status and diagnostic
<b>Start/Restart</b>	automatic or manual, selectable
<b>External Device Monitoring</b>	external device monitoring feedback input with enabling selectable
<b>Max. Muting Time-out</b>	30 sec., 90 min. or infinite selectable
<b>Override function</b>	built-in override function with 2 operating modes, selectable: - manual action with hold to run - automatic with pulse command
<b>Max. Override Time-out (min)</b>	15
<b>Power supply (VDC)</b>	24 ± 20%
<b>Electrical connections</b>	M12 5-pole for emitter M16 12-pole for receiver
<b>Max. cable length (m)</b>	100
<b>Operating temperature (°C)</b>	0 ... 55
<b>Protection rating</b>	IP 65
<b>Cross section (mm)</b>	35 x 45

#### MXL and MXL U SERIES

<b>Protected heights (mm)</b>	160 ... 1210 for 30 mm Resolution 160 ... 1810 for 40 mm Resolution
<b>Resolutions available (mm)</b>	30, 40
<b>Number of beams for access control</b>	2, 3, 4
<b>Max. range (m)</b>	8
<b>MXL Muting logic</b>	two-way with 2 sensors, for personnel access control and two way material transit
<b>MXL U Muting logic</b>	one-way with 2 sensors, for material exit only
<b>Muting Sensors</b>	external Muting sensors with relay or PNP output (dark-on logic)

#### MXL L SERIES

<b>Number of beams</b>	2, 3
<b>Operating range (m)</b>	1 ... 2,5
<b>Muting logic</b>	one-way with 2 sensors
<b>Muting Sensors</b>	optoelectronics with 2 crossed beams built-in – pre-aligned – pre-wired, with adjustable height and angle

#### MXL T SERIES

<b>Number of beams</b>	2, 3
<b>Operating range (m)</b>	1 ... 2,5
<b>Muting logic</b>	two-way with 2 sensors
<b>Muting Sensors</b>	optoelectronics with 2 crossed beams built-in – pre-aligned – pre-wired, with adjustable height and angle

**Model MXL - Two-way (entry/exit) - Max. range 8 m**

**Model MXL U - One-way (only exit) - Max. range 8 m**

**Model MXL T - Two-way (entry/exit) - Max. range from 1 to 2,5 m**

**Model MXL L - One-way (only exit) - Max. range from 1 to 2,5 m**



MXL Resolution 30 mm	MXL 153	MXL 303	MXL 453	MXL 603	MXL 753	MXL 903	MXL 1053	MXL 1203
Ordering codes	1344800	1344801	1344802	1344803	1344804	1344805	1344806	1344807
MXL U Resolution 30 mm	MXL U 153	MXL U 303	MXL U 453	MXL U 603	MXL U 753	MXL U 903	MXL U 1053	MXL U 1203
Ordering codes	1344850	1344851	1344852	1344853	1344854	1344855	134486	1344857
Protected height (mm)	160	310	460	610	760	910	1060	1210
Number of beams	8	16	24	32	40	48	56	64
Overall height (mm)	261	411	561	711	861	1011	1161	1311



MXL Resolution 40 mm	MXL 304	MXL 454	MXL 604	MXL 754	MXL 904	MXL 1054	MXL 1204	MXL 1354	MXL 1504	MXL 1654	MXL 1804
Ordering codes	1344811	1344812	1344813	1344814	1344815	1344816	1344817	1344823	1344819	1344824	1344825
MXL U Resolution 40 mm	MXL U 304	MXL U 454	MXL U 604	MXL U 754	MXL U 904	MXL U 1054	MXL U 1204	MXL U 1354	MXL U 1504	MXL U 1654	MXL U 1804
Ordering codes	1344861	1344862	1344863	1344864	1344865	1344866	1344867	1344868	1344869	1344870	1344871
Protected height (mm)	310	460	610	760	910	1060	1210	1360	1510	1660	1810
Number of beams	10	15	20	25	30	35	40	45	50	55	60
Overall height (mm)	411	561	711	861	1011	1161	1311	1461	1611	1861	1911



MXL 2, 3, 4 beams	MXL 2B	MXL 3B	MXL 4B
Ordering codes	1344820	1344821	1344822
MXL U 2, 3, 4 beams	MXL U 2B	MXL U 3B	MXL U 4B
Ordering codes	1344880	1344881	1344882
Number of beams	2	3	4
Beam spacing (mm)	500	400	300
Protected height (mm)	510	810	910
Overall height (mm)	711	1011	1111



MXL L 2, 3 beams	MXL L 2B	MXL L 3B	MXL T 2, 3 beams	MXL T 2B	MXL T 3B
Ordering codes	1344830	1344831	Ordering codes	1344840	1344841
Number of beams	2	3	Number of beams	2	3
Beam spacing (mm)	500	400	Beam spacing (mm)	500	400
Protected height (mm)	510	810	Protected height (mm)	510	810
Overall height (mm)	711	1011	Overall height (mm)	711	1011
Muting sensors	2 crossed beams		Muting sensors	2 crossed beams	

### SENSOR ELEMENT ADJUSTMENT - MXL L and MXL T versions

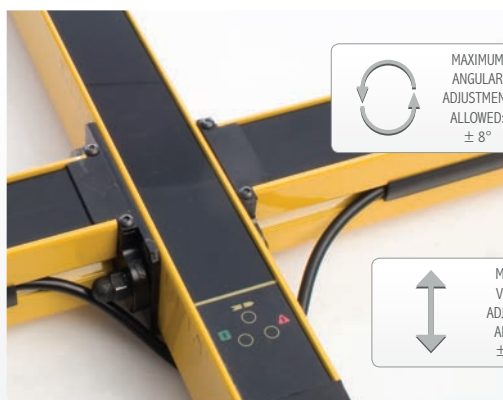

MAXIMUM ANGULAR ADJUSTMENT ALLOWED: ± 8°

MAXIMUM VERTICAL ADJUSTMENT ALLOWED: ± 70 mm

The sensor elements present in the Vision MXL L and MXL T versions are adjustable in height and angle.

This important and unique feature enables the inclination of the detection plane of the sensors to obtain correct and constant detection of irregular materials in transit.

► **"ACCESSORIES" on page 153**

## MXJB CONNECTION BOX FOR VISION MXL LIGHT CURTAINS

Connection boxes MXJB are accessory devices designed for quick, reliable connection of Vision MXL light curtains and to ensure that major operating controls needed for operation are available in the guarded area.

### MAIN FEATURES

- Start/Restart push button
- Key selector switch for Override control function
- Muting-on indicator lamp
- Light curtain connectors
- Dip-switch for light curtain functions configuration
- 2 guided-contacts safety relays operated and controlled by the light curtain
- Internal terminal blocks for cable connections.
- Selector for connection of external Muting lamp.
- Selector for internal or external relay control
- Connection for Muting enable input
- Connection with cable gland for cable passage in output towards the machine

MXJB is pre-set as manual Restart. By means the dedicated 5 meters cable CJBR5A, available as accessory, it is possible to make it work as automatic Restart.



Complying with:

- 2004/108/EC "Electromagnetic Compatibility (EMC)"
- 2006/95/EC "Low Voltage Directive (LVD)"
- UL (C+US) mark for USA and Canada.

### TECHNICAL FEATURES

MODELS	MXJB 1	MXJB 3
Ordering codes	1360934	1360935
Safety relay output	2 NO 2A 250 VAC	2 NO + 1 NC * 2A 250 VAC
Start/Restart button		yes
Override command		yes
Built-in Muting-lamp		yes
Connectors	M23 19-pole for receiver connection M12 5-pole for emitter connection	
Dimensions - h x w x d (mm)	110 x 180 x 110	

\* In MXJB 3 and MXJB 4 boxes each NO safety output line is interrupted twice by the two relays

### DIMENSIONS (mm)

#### MODELS STANDARD AND SLAVE

#### MODELS MASTER

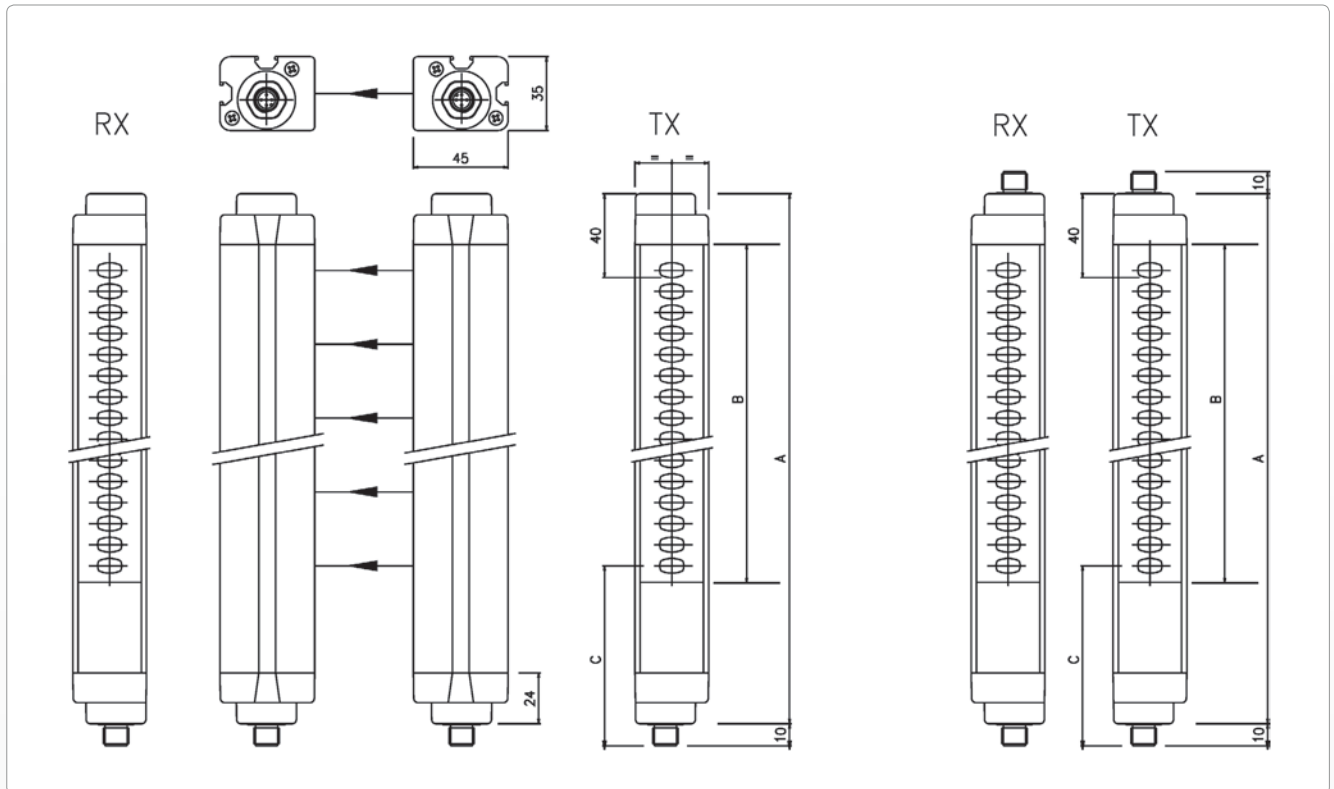

Models	150	300	450	600	750	900	1050	1200	1350	1500	1650	1800
A	251	401	551	701	851	1001	1151	1301	1451	1601	1751	1901
B (protected area)	160	310	460	610	760	910	1060	1210	1360	1510	1660	1810
C	85											
Mounting	Complete set of 4 LS type brackets included in the package							Complete set of 6 LS type brackets included in the package				

Models	2B	3B	4B
A	701	1001	1101
B	510*	810*	910*
C	135		
Mounting	Complete set of 4 LS type brackets included in the package		

\* for these models the protected height is only indicative and is calculated based on the beams spacing.



### WARNING!

When the light curtain works in the presence of strong vibrations (presses, weaving machines etc.), in order to avoid damages to the light curtain it is necessary to use the anti-vibration dampers SAV (available as accessories)

When long range protections or perimeter protections employing mirrors have to be realised it is advisable to use the LAD laser pointer as an alignment aid, as well as the adjustable swivel fastening brackets SFB.



## VISION MXL L

REFERENCE	2B	3B
A	711	1011

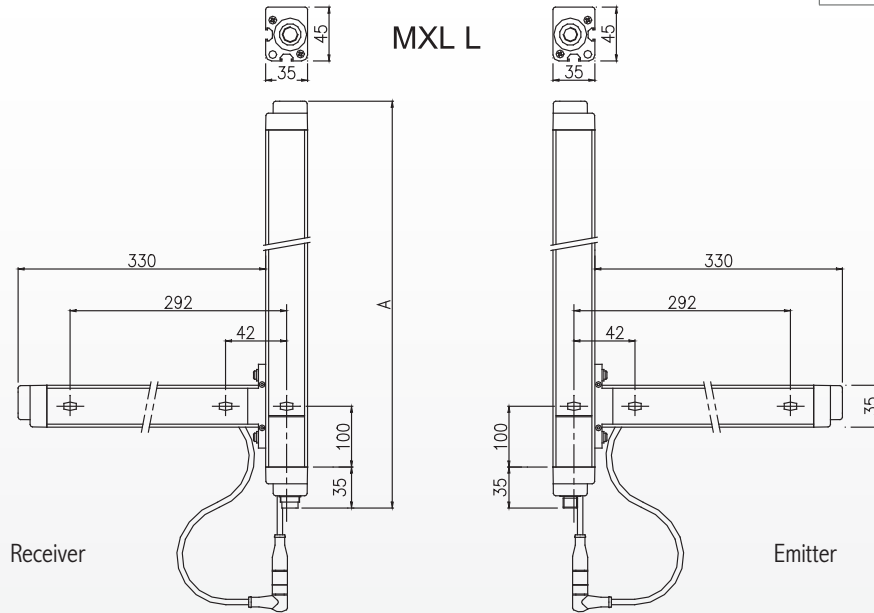

## VISION MXL T

REFERENCE	2B	3B
A	711	1011

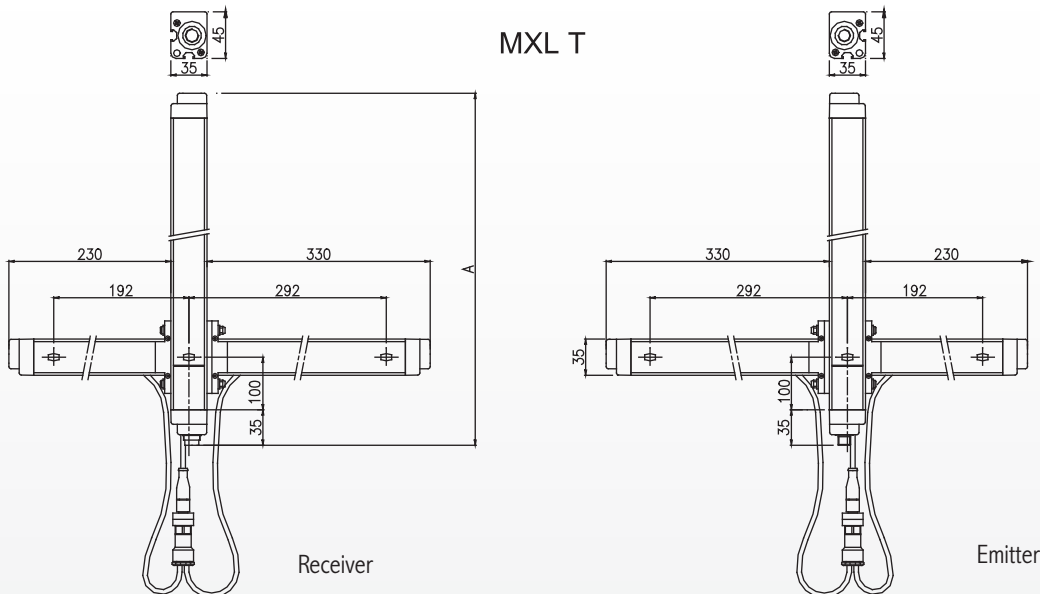

Note: The muting arms can be ordered separately.

► See page 83

### ORDERING INFORMATION

#### Each Vision light curtain comprises:

Emitter and Receiver pair
Mounting brackets and T-nuts
CD-ROM containing the multi-language instruction manual complete with CE declaration of conformity
Quick installation guide

### ACCESSORIES

#### For Vision light curtains the following accessories, to be ordered separately, are available:

AD SR Safety Relays	▶ See page 183
FMC floor mounting columns	▶ See page 220
SP deflection mirrors	▶ See page 223
LAD laser alignment device	▶ see page 224
SAV vibrations dampers	▶ See page 225
SFB swivel fixing brackets	▶ See page 226
Connectors	▶ See list hereunder
Addition muting arm for L Muting SLA and T Muting STA	▶ See page 83

Models	Code	Description
--------	------	-------------

#### CONNECTORS FOR VISION V emitters and receivers / VX-VXL-MXL-MXL U emitters

CD 5	1330950	M12 straight connector 5 poles pre-wired, cable 5 m
CD 10	1330956	M12 straight connector 5 poles pre-wired, cable 10 m
CD 15	1330952	M12 straight connector 5 poles pre-wired, cable 15 m
CD 20	1330957	M12 straight connector 5 poles pre-wired, cable 20 m
CD 25	1330949	M12 straight connector 5 poles pre-wired, cable 25 m
CD 50	1330965	M12 straight connector 5 poles pre-wired, cable 50 m
CD 95	1330951	M12 90° angle connector, 5 poles, pre-wired cable 5 m
CD 910	1330958	M12 90° angle connector, 5 poles, pre-wired cable 10 m
CD 915	1330953	M12 90° angle connector, 5 poles, pre-wired cable 15 m
CDM 9	1330954	M12 straight connector, 5 poles with screw terminal, PG9 cable gland
CDM 99	1330955	M12 angle connector, 5 poles with screw terminal, PG9 cable gland

#### CONNECTORS FOR VISION VX and VXL receivers

C8D 5	1330980	M12 straight connector 8 poles pre-wired, cable 5 m
C8D 10	1330981	M12 straight connector 8 poles pre-wired, cable 10 m
C8D 15	1330982	M12 straight connector 8 poles pre-wired, cable 15 m
C8D 25	1330967	M12 straight connector 8 poles pre-wired, cable 25 m
C8D 40	1330966	M12 straight connector 8 poles pre-wired, cable 40 m
C8D 95	1330983	M12 90° angle connector, 8 poles, pre-wired cable 5 m
C8D 910	1330984	M12 90° angle connector, 8 poles, pre-wired cable 10 m
C8D 915	1330985	M12 90° angle connector, 8 poles, pre-wired cable 15 m
C8DM 9	1330986	M12 straight connector 8 poles with screw terminal, PG9 cable gland
C8DM 911	1330987	M12 90° angle connector, 8 poles, with screw terminal, PG9 cable gland
C8DM 11	1330988	M12 straight connector, 8 poles with screw terminal, PG9/11 cable gland
C8DM 911	1330989	M12 90° angle connector, 8 poles, with screw terminal, PG9/11 cable gland

ACCESSORIES		
Models	Code	Description
<b>CONNECTORS FOR VISION MXL receivers</b>		
C12D 3	1330991	M16 straight connector 12 poles pre-wired, cable 3 m
C12D 5	1330992	M16 straight connector 12 poles pre-wired, cable 5 m
C12D 10	1330993	M16 straight connector 12 poles pre-wired, cable 10 m
C12D 15	1330996	M16 straight connector 12 poles pre-wired, cable 15 m
C12D 25	1330948	M16 straight connector 12 poles pre-wired, cable 25 m
CM 16	1330997	M16 straight connector 12 poles, solder terminal connector
<b>CABLES WITH 2 CONNECTORS FOR VISION MXL EMITTERS AND MXJ Box</b>		
CIBE 3	1360960	3 m pre-wired cable with 2 straight connectors, M12 5-pole
CIBE 5	1360961	5 m pre-wired cable with 2 straight connectors, M12 5-pole
CIBE 10	1360962	10 m pre-wired cable with 2 straight connectors, M12 5 pole
<b>CABLES WITH 2 CONNECTORS FOR VISION MXL RECEIVERS AND MXJ Box</b>		
CMBR 3	1360975	3 m pre-wired cable with 1 straight connector, M16 12-pole and 1 straight connector, M23 19-pole
CMBR 5	1360976	5 m pre-wired cable with 1 straight connector, M16 12-pole and 1 straight connector, M23 19-pole
CMBR 5 A	1360978	5 m pre-wired cable with 1 straight connector, M16 12-pole and 1 straight connector, M23 19-pole for automatic Restart
CMBR 10	1360977	10 m pre-wired cable with 1 straight connector, M16 12-pole and 1 straight connector, M23 19-pole
<b>CONNECTION BETWEEN MASTER AND SLAVE</b>		
CDS 03	1330990	0,3 m pre-wired cable with 2 straight connectors, M12 5-pole
CIBE 3	1360960	3 m pre-wired cable with 2 straight connectors, M12 5-pole
CIBE 5	1360961	5 m pre-wired cable with 2 straight connectors, M12 5-pole
CIBE 10	1360962	10 m pre-wired cable with 2 straight connectors, M12 5-pole
CIBE 25	1360963	25 m pre-wired cable with 2 straight connectors, M12 5 pole

# ILION



# ULISSE

# ILION

## MAIN FEATURES

ILION is a Type 2 safety photocell with M18 cylindrical metal body.

The photocells must be connected to control unit for example: standard AU SX or AU SXM control unit with Muting or Mosaic to form a protection system that can be composed of 1, 2, 3 or 4 single beam photocells.

In case of connection with Mosaic safety controller, the number of photocells depends to the configuration of the protection system. (for details on the interface see AU SX, AU SXM and Mosaic control units).

The compact size of the photocells makes it possible to fit the protection system into very small spaces, while the possibility to use more photocells provides the maximum flexibility in positioning the protective beams.



## PHOTOELECTRIC SENSOR TECHNICAL DATA

Model	IL 10	IL 20
Ordering code	1200201	1200201
Safety level (with control unit AUS X or AUS XM)	Type 2 according to IEC/TS 61496-2 SIL 2 – SILCL 2 according to IEC 61508 - IEC 62061 PL d – Cat. 2 according to ISO 13849-1 (With a control unit AU XS, AU SXM or Mosaic)	
Minimum detectable object (mm)	12	
Max. range (m)	8	20
Number of photocells per control unit	1 ... 4 with AU SX and AU SXM control units. In case of the Mosaic safety controller the number of photocells depends to the number available input related to the system configuration	
Response time for each photocell (ms)	7	
Output	PNP - 100 mA	
Signalling	status led	
Power supply (VDC)	24 ± 20%	
Electrical connections	M12 4-pole	
Max. cable length (m)	50 (between sensor and control unit)	
Operating temperature (°C)	0 ... 55	
Protection rating	IP 67	
Dimensions (mm)	Ø 18 x 85	

Safety level

**TYPE 2**

**SIL 2 – SILCL 2  
PL d – Cat. 2**



ORDERING INFORMATION

**Each Ilion photocell includes:**

Emitter and Receiver pair

Multi-language instruction manual complete with CE declaration of conformity

CONNECTORS

The following connectors are available for the Ilion photocells, to be ordered separately:

Model	Code	Description
CD 5	1330950	M12 straight connector, 5 poles, pre-wired cable 5 m
CD 10	1330956	M12 straight connector, 5 poles, pre-wired cable 10 m
CD 15	1330952	M12 straight connector, 5 poles, pre-wired cable 15 m
CD 20	1330957	M12 straight connector, 5 poles, pre-wired cable 20 m
CD 25	1330949	M12 straight connector, 5 poles, pre-wired cable 25 m
CD 95	1330951	M12 90° angle connector, 5 poles, pre-wired cable 5 m
CD 910	1330958	M12 90° angle connector, 5 poles, pre-wired cable 10 m
CDM 915	1330953	M12 90° angle connector, 5 poles, pre-wired cable 15 m
CDM 9	1330954	M12 straight connector, 5 poles with screw terminal, PG9 cable gland
CDM 99	1330955	M12 90° angle connector, 5 poles with screw terminal, PG9 cable gland



ADJUSTABLE FIXING BRACKET

Model	Code	Description
IL FB	1200090	Set of 2 adjustable brackets
The IL FB bracket permits both vertical and horizontal adjustment of the optical axis of the photocell.		

# ULISSE

## MAIN FEATURES

ULISSE is a Type 2 safety photocell with metal body and M8 3-pole connector.

The photocells must be connected to control unit for example: standard AU SX or AU SXM control unit with Muting or Mosaic to form a protection system that can be composed of 1, 2, 3 or 4 single beam photocells.

In case of connection with Mosaic safety controller, the number of photocells depends to the configuration of the protection system. (for details on the interface see AU SX, AU SXM and Mosaic control units).

Thanks to the very small size, the anodised aluminium case and the glass lenses free from electrostatic dust attraction, ULISSE is the ideal solution for the protection of weaving machines as well as of other applications characterised by high levels of mechanical stress or very restricted spaces.



## PHOTOELECTRIC SENSOR TECHNICAL DATA

Model	UPC
<b>Ordering code</b>	1200300
<b>Safety level</b>	Type 2 according to IEC/TS 61496-2 SIL 2 – SILCL 2 according to IEC 61508 - IEC 62061 PL d – Cat. 2 according to ISO 13849-1 (with control unit AUS X, AUS XM or Mosaic)
<b>Minimum detectable object (mm)</b>	8
<b>Max. range (m)</b>	6
<b>Number of photocells per control unit</b>	1 ... 4 In case of the Mosaic safety controller the number of photocells depends to the number available input related to the system configuration
<b>Response time for each photocell (ms)</b>	7
<b>Output</b>	PNP - 100 mA
<b>Signalling</b>	status led
<b>Power supply (VDC)</b>	24 ± 20%
<b>Electrical connections</b>	M8 3-pole
<b>Max. cable length (m)</b>	50 (between sensor and control unit)
<b>Operating temperature (°C)</b>	0 ... 55
<b>Protection rating</b>	IP 65
<b>Dimensions - h x w x d (mm)</b>	58 x 15 x 25

## ORDERING INFORMATION

### Each Ulisse photocell includes:

Emitter and Receiver pair

Multi-language instruction manual complete with CE declaration of conformity

## CONNECTORS

The following connectors are available for the Ulisse photocells, to be ordered separately:

Model	Code	Description
C 85	1200217	M8 straight connector, 3 poles, pre-wired cable 5 m
C 815	1200219	M8 straight connector, 3 poles, pre-wired cable 15 m
C 895	1200216	M8 90° angle connector, 3 poles, pre-wired cable 5 m



Safety Level:

# TYPE 2

**SIL 2 – SILCL 2**  
**PL d – Cat. 2**

# MAGNUS





# MG S - RECTANGULAR COMPACT HOUSING

## MAIN FEATURES

Compact and robust thermoplastic enclosure (PBT):  
 22 mm fixing  
 IP67 rating  
 Operating temperature -25 to +75°C  
 Coded magnetic operation – Tamper resistant  
 Switching distance: 3 - 10 mm  
 Sensor with 4 wires: 2 NO contacts  
 M8 4-pole connector

Can be connected to Mosaic safety configurable controller (PL e) or to the dedicated safety control unit MG d1 (PL d).

**MG S switches connected to Mosaic safety controller form a certified PL e safety system.**



## TECHNICAL FEATURES

<b>Model</b>	<b>MG S 20</b>
<b>Ordering code</b>	1291000
<b>Safety Level</b>	PL e together with Mosaic - Up to PL d together with MG d1
<b>Operating voltage (VDC)</b>	24
<b>Switching current (mA)</b>	max. 100
<b>Series resistance (Ohm)</b>	22
<b>Switching power (W)</b>	3
<b>Shock resistance (Hz/g)</b>	10 - 2000/35
<b>Protection rating</b>	IP 67
<b>Temperature range (°C)</b>	- 25 ... + 75
<b>Housing material</b>	PBT
<b>Possible actuation magnets</b>	<b>MG S M</b> to be ordered separately (code 1291001)

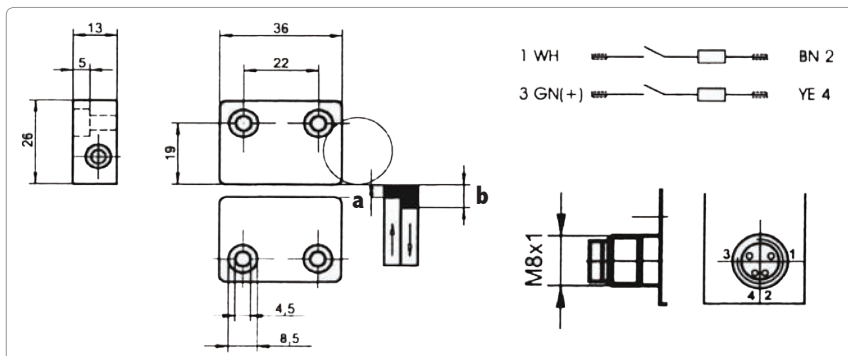

### Gaps (operating distance) for safe switching function in mm:

<b>MIN</b>	0,5	-
<b>ON</b>	3	<b>a</b>
<b>OFF</b>	10	<b>b</b>

MIN = minimum gap



## ORDERING INFORMATION

Each MG B safety magnetic switch includes:

Multi-language operating instructions complete with CE declaration of conformity.

## MG B - RECTANGULAR HOUSING

### MAIN FEATURES

Robust thermoplastic enclosure:  
 78 mm fixing  
 IP67 rating  
 Operating temperature -25 to +75°C  
 Coded magnetic operation – Tamper resistant  
 Switching distance: 4 - 16 mm; 7 - 18 mm with magnet MG B M+  
 Sensor with 4 wires: 2 NO contacts  
 M8 4-pole connector

Can be connected to Mosaic safety configurable controller (PL e) or to the dedicated safety control unit MG d1 (PL d).

**MG B switches connected to Mosaic safety controller form a certified PL e safety system.**



### TECHNICAL FEATURES

<b>Model</b>	<b>MG B 20</b>
<b>Ordering code</b>	1291010
<b>Safety Level</b>	PL e together with Mosaic - Up to PL d together with MG d1
<b>Operating voltage (VDC)</b>	24
<b>Switching current (mA)</b>	max. 100
<b>Series resistance (Ohm)</b>	22
<b>Switching power (W)</b>	3
<b>Shock resistance (Hz/g)</b>	10 - 2000/35
<b>Protection rating</b>	IP 67
<b>Temperature range (°C)</b>	- 25 ... + 75
<b>Housing material</b>	PBT
<b>Possible actuation magnets</b>	<b>MG B M</b> to be ordered separately (code 1291011)
<b>Possible actuation reinforced magnets</b> (only use reinforced actuation magnets if a gap of more than 4 mm is unavoidable)	<b>MG B M+</b> to be ordered separately (code 1291012)

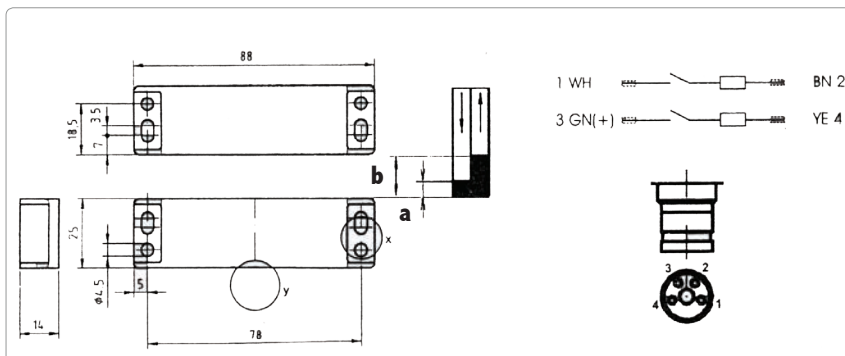

### Gaps (operating distance) for safe switching function in mm:

<b>MIN</b>	normal	0,5	
	with + magnet	3	
<b>ON</b>	normal	4	<b>a</b>
	with + magnet	7	<b>a</b>
<b>OFF</b>	normal	16	<b>b</b>
	with + magnet	18	<b>b</b>

+ = reinforced      MIN. = minimum gap



### ORDERING INFORMATION

Each MG B safety magnetic switch includes:

Multi-language operating instructions complete with CE declaration of conformity

# MG M - M30 HOUSING

## MAIN FEATURES

Robust cylindrical thermoplastic enclosure:  
 30mm diameter  
 IP67 rating  
 Operating temperature -25 to +75°C  
 Coded magnetic operation – Tamper resistant  
 Switching distance: 4 - 16 mm; 7 - 20 mm with magnet MG M M+  
 Sensor with 4 wires: 2 NO contacts  
 M8 4-pole connector

Can be connected to Mosaic safety configurable controller (PL e) or to the dedicated safety control unit MG d1 (PL d).

**MG M switches connected to Mosaic safety controller form a certified PL e safety system.**

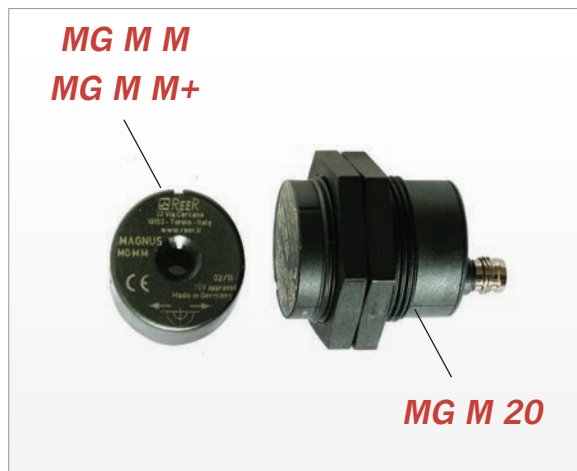

## TECHNICAL FEATURES

<b>Model</b>	<b>MG M 30</b>
<b>Ordering code</b>	1291020
<b>Safety Level</b>	PL e together with Mosaic - Up to PL d together with MG d1
<b>Operating voltage (VDC)</b>	24
<b>Switching current (mA)</b>	max. 100
<b>Series resistance (Ohm)</b>	22
<b>Switching power (W)</b>	3
<b>Shock resistance (Hz/g)</b>	10 - 2000/35
<b>Protection rating</b>	IP 67
<b>Temperature range (°C)</b>	-25 ... +75
<b>Housing material</b>	PBT
<b>Possible actuation magnets</b>	<b>MG M M</b> (code: 1291021)
<b>Possible actuation reinforced magnets</b> (only use reinforced actuation magnets if a gap of more than 4 mm is unavoidable)	<b>MG M M+</b> (code: codice 1291022)

### Gaps (operating distance) for safe switching function in mm:

MIN	normal	0,5	
	with + magnet	3	
ON	normal	4	<b>a</b>
	with + magnet	7	
OFF	normal	16	<b>b</b>
	with + magnet	20	



+ = reinforced      MIN. = minimum gap

## ORDERING INFORMATION

Each MG M safety magnetic switch includes:

Multi-language operating instructions complete with CE declaration of conformity

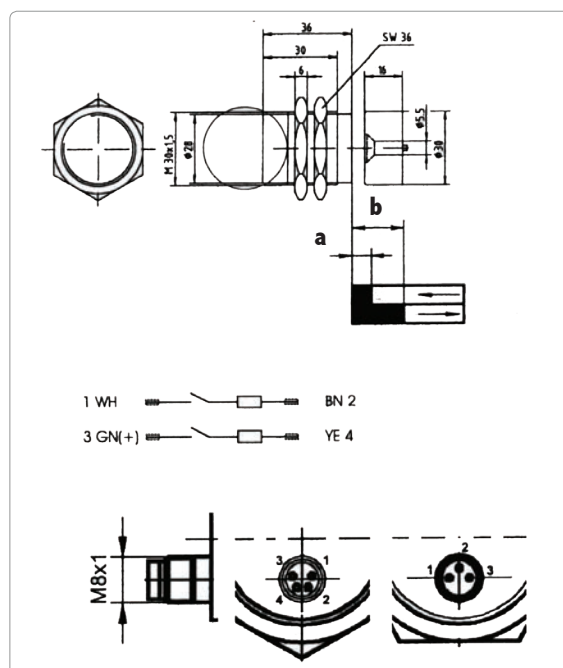

### CONNECTORS FOR MAGNUS

The following connectors are available for Magnus magnetic safety switches

Model	Code	Description
C8 G3	1291070	M8 straight connector, 4-pole, 3 m cable
C8 G93	1291071	M8 angled 90° connector, 4-pole, 3 m cable
C8 G5	1291072	M8 straight connector, 4-pole, 5 m cable
C8 G95	1291073	M8 angled 90° connector, 4-pole, 5 m cable



Magnus magnetic switches together with Mosaic comprise a PLe certified system according to ISO 13849-1.

Certified by



► See page 165



Magnus magnetic switches together with the MG d1 control unit comprise a PL d certified system according to ISO 13849-1.

Certified by



► See page 189



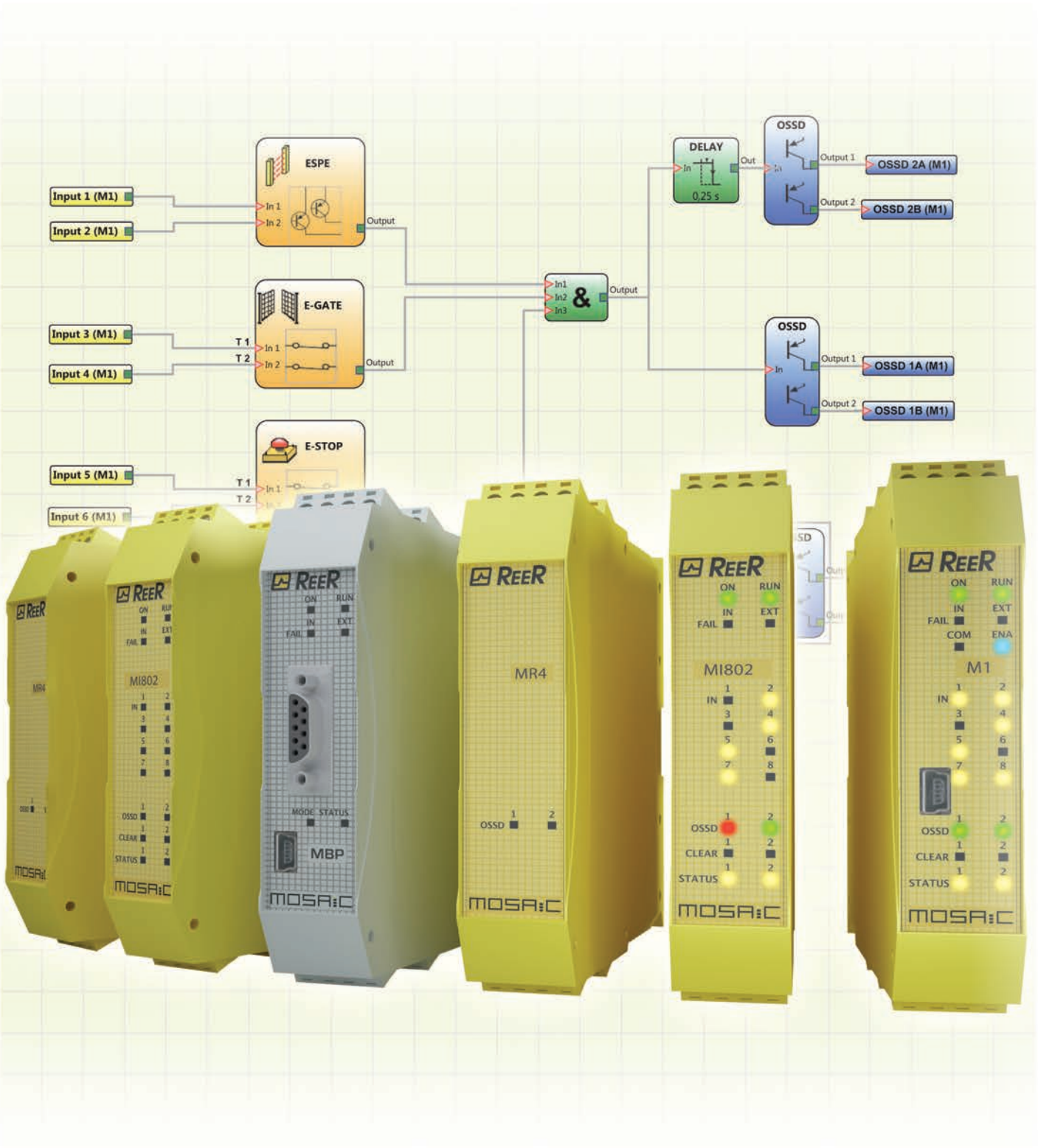

## INTRODUCTION

Mosaic is a modular, configurable safety controller for protecting machines or plants. Mosaic is capable of monitoring several safety sensors and commands, such as safety light curtains, laser scanners, photocells, mechanical switches, mats, emergency stops, two-hand controls, concentrating management of these in a single, flexible device. Thanks to MCT modules, parts of the Mosaic System can be decentralized in remote cabinets with respect to the master unit M1.

Mosaic offers numerous advantages compared with safety solutions based on traditional components, such as relay type safety modules, as it:

- Reduces the number of components and therefore footprint and wiring. Promotes faster electrical cabinet construction.
- Affords the necessary logical configuration using a single, simple programming software, facilitating modifications by machine designers.
- Makes it possible to set up tamper-proof safety systems.
- Simplifies machine maintenance through the MCM memory card, which can be used to transfer the configuration program to a new Mosaic in just a few simple steps.



Mosaic is certified to the highest safety levels established by industrial safety standards: SIL 3, SILCL 3, PL e, Cat. 4.

## SYSTEM DESCRIPTION

Mosaic comprises a master unit M1 configurable via the MSD (Mosaic Safety Designer) graphic interface – provided with each master unit at no extra cost and a maximum of 14 expansion units connectable to M1 via the MSC proprietary bus. The main features can be summarized in the following list:

- can be used with the main safety sensors and commands;
- digital safety inputs, programmable individually or in pairs, with the possibility of monitoring via dedicated output signals;
- wide range of software-configurable safety functions and logical operators;
- possibility of programming filters and delays for each single input and possibility of programming output activation and de-activation delays;
- possibility of independent control of pairs of outputs;
- max. 14 expansion units in addition to the M1 Master, excluding relay modules;
- max. 128 inputs, 16 OSSD pairs, 16 feedback restart e/o interlock inputs and 32 status outputs;
- simple diagnostics via front led signalling and configuration software;
- compact design: single module dimensions 22.5 x 99 x 114.5 mm;
- removable terminal blocks, screw contacts.

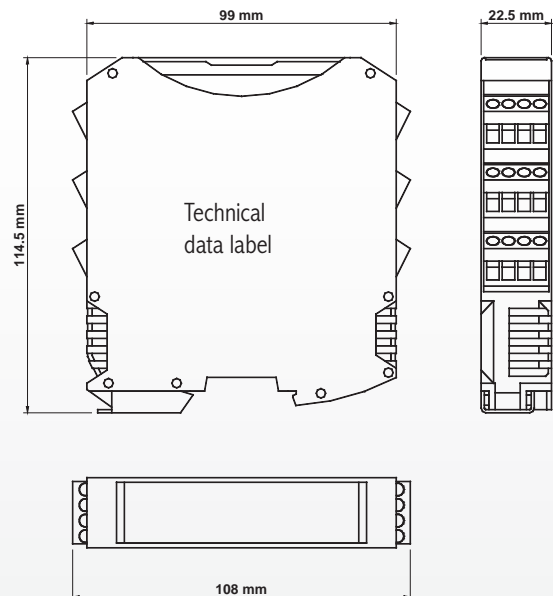

### Safety level: SIL 3 – SILCL 3 – PL e – Cat. 4 – Type 4

- 2006/42/EC “Machinery Directive”
- 2004/108/EC “Electromagnetic Compatibility (EMC)”
- 2006/95/EC “Low Voltage Directive (LVD)”
- CEI EN 61131-2 “Programmable Controllers. Part 2: Equipment requirements and tests”
- EN ISO 13849-1,2 “Safety of machinery: Safety-related parts of control systems. Part 1: General principles for design”. Part 2: Validation”
- EN 954-1 “Safety of machinery – Safety-related parts of control systems - General principles for design”
- IEC/EN 61496-1 “Safety of machinery: Electro-Sensitive Protection Equipment. Part 1: General requirements and tests”
- IEC/EN 62061 “Safety of machinery - Functional safety of safety-related electrical, electronic and programmable electronic control systems”
- IEC 61508-1,2 “Functional safety of electrical, electronic and programmable electronic safety-related systems. Part 1: General requirements” Part 2: Requirements for electrical, electronic and programmable electronic safety-related systems”
- IEC 61508-3: “Functional safety of electrical, electronic and programmable electronic safety-related systems – Part 3: Software requirements”
- IEC 61784-3: “Industrial communication networks - Profiles - Part 3: Functional safety fieldbuses - General rules and profile definitions”
- IEC/TS 62046 Ed. 2 “Safety of machinery - Application of protective equipment to detect the presence of persons”
- UL (C+US) mark for USA and Canada
- AUSI /UL 1998 “Safety Software in Programmable Components”.



Safety level:
<b>SIL 3</b>
<b>SIL 3 – SILCL 3</b>
<b>PL e – Cat. 4</b>

**USB connection**

The Mosaic M1 master is equipped with a USB 2.0 serial bus for the connection to a PC on which the MSD (Mosaic Safety Designer) configuration software is held.

**Mosaic Configuration Memory – MCM**

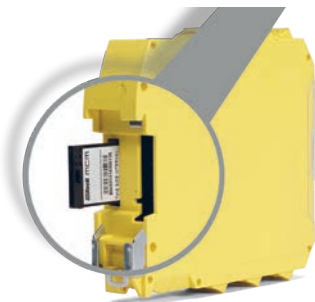

Mosaic MCM is a proprietary removable memory card that can be used to save Mosaic configuration data for subsequent transfer to a new device without using a PC.

The configuration in the MCM overwrites any other configuration present on M1, replacing this with that contained in MCM.

This configuration replacement function can be disabled on M1 via the MSD (Mosaic Safety Designer) configuration software. Overwrite operations are recorded in chronological order in the MOSAIC M1 LOG file.

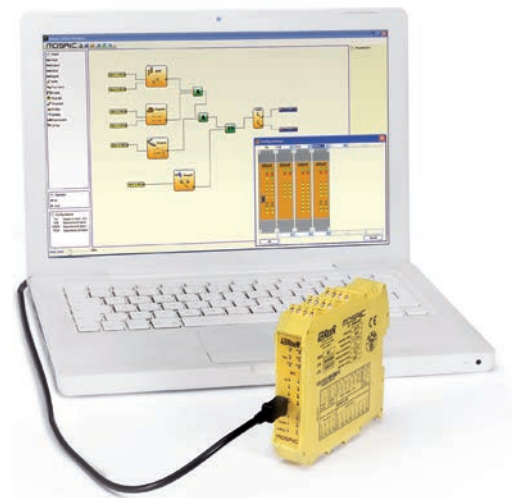

**Mosaic Safety Communication – MSC**



Mosaic MSC permits communication between the various units through a proprietary 5 high-speed safety bus.

The MSC modular connectors can be used to connect the various expansion units to M1. The connectors are physically located on the back of each unit and are housed in the rail guide of the electrical cabinet.

The M1 master unit does not include the MSC connector (not necessary if expansion units are not used). To connect the M1 to the first expansion unit, one MSC connector must be ordered. Each expansion unit is supplied with its own MSC connector.

**Expansion modules for safety speed monitoring**

- **MV0** - Input for 2 PNP/NPN proximity switches
- **MV1** - Input for 1 incremental encoder and 2 PNP/NPN proximity switches
- **MV2** - Input for 2 incremental encoders and 2 PNP/NPN proximity switches

Safety speed monitoring (up to PLe) for: zero speed control, Max. speed, speed range and direction

Up to 4 logically selectable speed thresholds (freely configurable via MSD) for each logical output (axis)

The modules includes two configurable via MSD logical outputs and is therefore able to control up to two independent axis

▶ See Safecoder safety encoder on page 179

**BUS modules allowing the connection of remote expansions.**

- **MCT1** - 1 connection interface (1 I/O cable - 1 input or 1 output)\*
- **MCT2** - 2 connections interface (2 I/O cable 1 input and 1 output)

Interface module allowing the connection of remote expansions via the MSC bus.

Up to 50 m for each connection (Total distance up to 250 m).

Ideal solution for the interconnection of the safety functions of more machineries on a single production line.

\* End of the network or Start of the network.

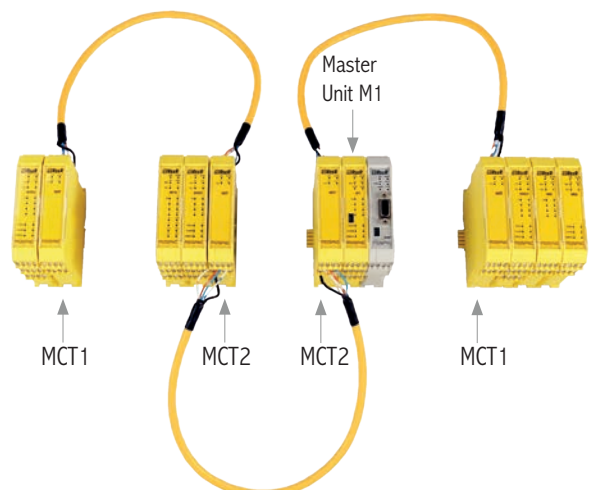
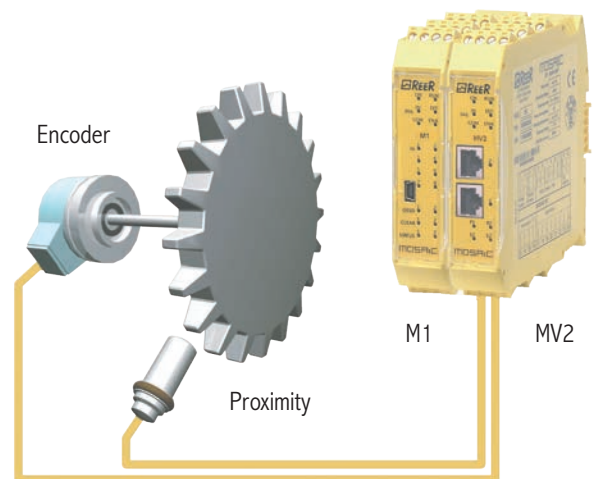



## Modules description (main and expansion units)

<p><b>Master module M1</b></p> <p>Main unit, also usable as a stand-alone device, able to control any other expansion units</p> <ul style="list-style-type: none"> <li>8 digital inputs</li> <li>2 inputs for Start/Restart interlock and external device monitoring (EDM)</li> <li>2 OSSD pairs with 400 mA output current</li> <li>4 test outputs for sensor monitoring</li> <li>2 programmable digital signal outputs</li> <li>MCM configuration memory card (optional)</li> <li>LOG file containing the last 5 configuration modifications in chronological order, with date of modification</li> <li>24 connectors in 22.5 mm</li> <li>Possible connection with Reer MSC rear bus for connection with other expansion units</li> <li>Configurable from PC via USB interface using MSD software.</li> </ul>			
<p><b>MOSAIC MI802</b></p> <p>I/O expansion unit.</p> <ul style="list-style-type: none"> <li>8 digital inputs</li> <li>2 inputs for Start/Restart interlock and external device monitoring (EDM)</li> <li>2 OSSD pairs with 400mA output current</li> <li>4 test outputs for sensor monitoring</li> <li>2 programmable digital signal outputs</li> <li>Connectable to M1 via MSC proprietary bus.</li> </ul>		<p><b>MOSAIC MI8 – MI16</b></p> <p>Input expansion unit:</p> <ul style="list-style-type: none"> <li><b>MI8</b> – 8 digital inputs</li> <li><b>MI16</b> – 16 digital inputs</li> <li>4 test outputs for sensor monitoring</li> <li>Connectable to M1 via MSC proprietary bus.</li> </ul>	
<p><b>MOSAIC MI12T8</b></p> <p>Input expansion unit.</p> <ul style="list-style-type: none"> <li>12 digital inputs</li> <li>8 test outputs for sensor monitoring: can control up to four 4-wire safety mats</li> <li>Connectable to M1 via MSC proprietary bus.</li> </ul>		<p><b>MOSAIC MO2 – MO4</b></p> <p>Output expansion units:</p> <ul style="list-style-type: none"> <li>2/4 inputs for Start/Restart interlock and external device monitoring (EDM)</li> <li><b>MO2</b> - 2 OSSD pairs</li> <li><b>MO4</b> - 4 OSSD pairs</li> <li>Output current - 400mA</li> <li>2/4 programmable digital signal outputs</li> <li>Connectable to M1 via MSC proprietary bus.</li> </ul>	
<p><b>MOSAIC MR2 – MR4</b></p> <p>Safety relay modules.</p> <ul style="list-style-type: none"> <li><b>MR2</b> - 2 relays – 2 NO + 1 NC connectable to 1 OSSD pair + 1 NC contacts for external device monitoring (EDM)</li> <li><b>MR4</b> - 4 relays – 4 NO + 2 NC connectable to 2 independent OSSD pairs + 2 NC contacts for external device monitoring (EDM)</li> <li>2/4 safety relays with 6A 250 VAC guided contacts</li> </ul> <p>Each NO contact is interrupted twice by 2 safety relays. Mosaic MR2 and MR4 are passive units that can also be used separately from the Mosaic system.</p> <p><b>The MR expansion units do not require MSC as they are wired directly to the selected OSSD.</b></p>		<p><b>MOSAIC MOR4 - MOR4 S8 NEW PRODUCT</b></p> <p>Safety relay expansion units with configurable outputs.</p> <ul style="list-style-type: none"> <li>4 internal safety relays with guided contacts 6A 250 VAC</li> <li>4 inputs for Start/Restart interlock and external device monitoring (EDM)</li> <li>The relay outputs can be configured via the MSD software as: <ul style="list-style-type: none"> <li>4 single-channel outputs (safety category 1 or 2) or</li> <li>2 dual-channels outputs (safety category 4)</li> </ul> </li> <li>Model <b>MOR4 S8</b> also has 8 programmable digital signal outputs</li> <li>Connectable to M1 through MSC Bus.</li> </ul>	

**MOSAIC MB**

Expansion unit for connection to the most common industrial Fieldbus systems for diagnostics and data communication.

- MBP - Profibus DP
- MBD - DeviceNET
- MBC - CANopen
- MBEI - Ethernet IP
- MBEC - EtherCAT
- MBEP - PROFINET
- MBU - Universal Serial Bus.

Connectable to M1 via MSC proprietary bus.



**MOSAIC MCT** NEW PRODUCT

Interface module allowing the connection of remote expansions via the MSC bus.

- **MCT1** - 1 connection interface (1 I/O cable)\*
- **MCT2** - 2 connections interface (2 I/O cable).

Available serial interface shielded cables: MC25 - 25 m; MC50 - 50 m; MC100 - 100 m

We recommend the use of ReeR's cables for a correct operation of the system.



**MOSAIC MV** NEW PRODUCT

Expansion modules for safety speed monitoring

- **MV0** - Input for 2 PNP/NPN proximity switches
- **MV1** - Input for 1 incremental encoders and 2 PNP/NPN proximity switches
  - MV1T (1 TTL encoder + 1 or 2 proximity switches)
  - MV1H (1 HTL encoder + 1 or 2 proximity switches)
  - MV1S (1 SIN/COS encoder + 1 or 2 proximity switches)
- **MV2** - Input for 2 incremental encoders and 2 PNP/NPN proximity switches
  - MV2T (1 or 2 TTL encoders + 1 or 2 proximity switches)
  - MV2H (1 or 2 HTL encoders + 1 or 2 proximity switches)
  - MV2S (1 or 2 SIN/COS encoders + 1 or 2 proximity switches)
- RI-45 (1 for MV1, 2 for MV2) connectors for encoders and terminal blocks for proximity switches
- Max input frequency for encoders: up to 500 KHz (300 KHz for HTL encoder)
- Max input frequency for proximity switches: up to 5 KHz.



**ORDERING INFORMATION**

A CD-ROM containing the MSD configuration software multi-language instruction manual and CE declaration of conformity is supplied with each M1 unit.

The M1 master unit does not include the MSC connector. To connect the M1 to the first expansion unit one, MSC connector must be ordered. (Not necessary if expansion units are not used).

Each expansion unit is supplied with its own MSC connector.

The MR2 and MR4 safety relay modules are only connected to the other units via hard-wiring and therefore do not require the MSC connector.

**ACCESSORIES ORDERING CODE**

Model	Ordering code	Description
MCM	1100060	Mosaic Configuration Memory – Memory Card
MSC	1100061	Mosaic Safety Communication – Connector
CSU	1100062	USB A cable – mini B, length 1,8 m
MC25	1100063	MCT serial cable for MSC bus transfer 25 m
MC50	1100064	MCT serial cable for MSC bus transfer 50 m
MC100	1100065	MCT serial cable for MSC bus transfer 100 m

### TECHNICAL FEATURES & ORDERING CODES

Module	M1	MI802	MI8 MI16	MI12T8	M02 M04	MR2 MR4	MCT1 MCT2	MOR4 MOR4 S8	MV	MBx
<b>Ordering code</b>	1100000	1100010	1100020 1100021	1100022	1100030 1100031	1100040 1100041	1100058 1100057	1100042 1100043	see table below	see table below
<b>Description</b>	Master unit	I/O Expansion unit	Input Expansion units	Input Expansion unit	Output Expansion units	Guided contact relay output Expansion units	Bus Transfer Expansion units	Safety relay configurable output Expansion units	Safety speed control Expansion units	Expansion units for bus
<b>USB</b>	yes	-	-	-	-	-	-	-	-	yes
<b>Housing for MCM</b>	yes	-	-	-	-	-	-	-	-	-
<b>Connection with MSC bus</b>	yes	yes	yes	yes	yes	-	yes	yes	yes	yes
<b>MSC connector provided</b>	no	yes	yes	yes	yes	-	yes	yes	yes	yes
<b>Safety Level</b>	SIL 3 – SILCL 3 according to IEC 61508 - IEC 62061 / PL e – Cat. 4 according to ISO 13849-1									-
<b>Safety inputs</b>	8	8	8 or 16	12	-	-	-	-	2 or 4	-
<b>Safety outputs (OSSD)</b>	2 pairs PNP 400 mA	2 pairs PNP 400 mA	-	-	2 or 4 pairs PNP-400 mA	1 or 2 pairs	-	-	-	-
<b>Programmable signal outputs status</b>	2 PNP 100 mA	2 PNP 100 mA	-	-	2 or 4 PNP 100 mA	-	-	<b>MOR4 S8</b> 8 PNP 100 mA	-	-
<b>Test outputs</b>	4	4	4	8	-	-	-	-	-	-
<b>Safety relay outputs</b>	-	-	-	-	-	2 NO + 1 NC 4 NO + 2 NC 6 A 250 VAC	-	4 NO single 6 A 250 VAC or 2 NO pairs 6 A 250 VAC	-	-
<b>Start/Restart inputs and External Device Monitoring (EDM)</b>	2	2	-	-	2 or 4	-	-	4	-	-
<b>Led signalling</b>	Input/output status and fault diagnostics					Output status			Input status and fault diag.	Fault diag.
<b>Power supply (VDC)</b>	24 ± 20%									
<b>Electrical connections</b>	Removable terminal blocks, screw contacts									
<b>Operating temperature</b>	-10 ... 55 °C									
<b>Storage temperature</b>	- 20 ... 85 °C									
<b>Protection rating</b>	IP 20 for housing / IP 2X for terminal block									
<b>Fastening</b>	DIN rail fastening according to EN 50022-35 standard									
<b>Dimension (h x w x d)</b>	99 x 22,5 x 114									

#### MBx ordering codes

#### MV ordering codes

Model	Description	Ordering code	Model	Description	Ordering code
<b>MBP</b>	Expansion unit Profibus DP	1100050	<b>MV1T</b>	1 TTL encoder expansion unit	1100070
<b>MBD</b>	Expansion unit DeviceNet	1100051	<b>MV1H</b>	1 HTL encoder expansion unit	1100071
<b>MBC</b>	Expansion unit CANopen	1100052	<b>MV1S</b>	1 Sin/Cos encoder expansion unit	1100072
<b>MBEC</b>	Expansion unit EtherCAT	1100053	<b>MV2T</b>	2 TTL encoder expansion unit	1100073
<b>MBEI</b>	Expansion unit Ethernet IP	1100054	<b>MV2H</b>	2 HTL encoder expansion unit	1100074
<b>MBEP</b>	Expansion unit PROFINET	1100055	<b>MV2S</b>	2 Sin/Cos encoder expansion unit	1100076
<b>MBU</b>	Expansion unit Universal Serial Bus	1100056	<b>MVO</b>	Only proximity switches expansion unit	1100077

**MOSAIC SAFETY DESIGNER - MSD**

MSD (Mosaic Safety Designer) is the free of charge, easy-to-use and intuitive MOSAIC configuration software. MSD main features:

- “Drag&Drop” configuration of all safety functions
- Functional validation of design
- Configuration of parameters of function blocks
- Real-time monitoring of I/O status
- Single or bi-directional, 2 or 4 sensors muting function blocks
- 2-level passwords management for the prevention of unauthorised accesses and therefore of incidental modifications or tampering of the system configuration

**MAIN FUNCTIONAL BLOCKS**

The MSD interface allows configuration of the system functional blocks parameter.

**Safety input object**

For example: ESPE - opto-electronic safety barrier or safety laser scanner.

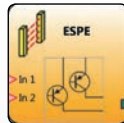

**Safety speed monitoring input object (new)**

For example: Safety speed monitoring for zero speed, Max. speed, speed range and direction



**Non safety input object**

For example: non-safety sensor and non-safety button or switch



**Output object**

For example: OSSD (safety outputs), STATUS (programmable signal output)

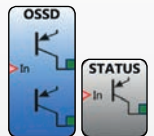

**OPERATORS**

The MSD interface allows configuration of the system operators parameter. The available object are:

**MUTING OPERATORS**

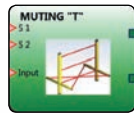

The Muting function permits the automatic, temporary and safe disabling of the ESPE at certain stages in the machine cycle. There are two main types of applications:

- To permit access to the hazardous area by personnel during the non-hazardous part of the machine cycle.
- To permit the passage of materials and prevent access by personnel. For example: palletizer applications.

**GUARD LOCK OPERATOR (new)**

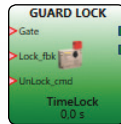

Allows you to control a safety lock verifying the consistency between the lock/unlock command and E-GATE and feedback status.

**NETWORK OPERATOR (new)**

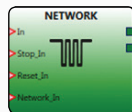

The Network operator is used to distribute Stop and Restart command via a simple local network in form of loop.

It is possible to Stop and Restart all machines (Mosaic) of the loop from any position.

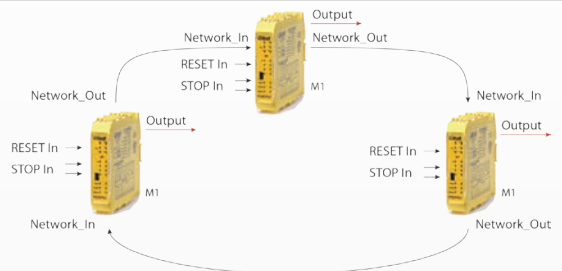

**SERIAL OUTPUT (new)**

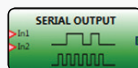

Returns as output the status of max 8 inputs through a simulated serial line.

**MEMORY OPERATORS**



Allow the user to store signals coming from the objects forming the application. For example: D FLIP FLOP, MANUAL USER RESTART, MONITORED USER RESTART.

**TIMER OPERATORS**



Timer type operators permit generation of a signal for the set time. For example: DELAY, MONOSTABLE; CLOCKING

**COUNTER OPERATOR**



Counter type operator permits generation of a signal on reaching the set number.

**LOGICAL OPERATORS**



For example: AND, OR, NAND, NOR, XOR, NOT e multiplexer.

## APPLICATION EXAMPLE 1

### Safety management of a palletizing system with two robotic cells

The system comprises a conveyor that transports boxes to two robotic palletization cells.

The machine is completely protected by a fence with three access gates (one for each robotic cell and one for the conveyor area) equipped with a safety switch. When the gate of the robotic cell is opened, the corresponding robot stops. When the conveyor area gate is opened the entire plant stops.

The completed pallets are collected by a forklift truck through the access gate which is protected by a safety light curtain. The access of the forklift truck for collecting the pallet, when the robot is stopped in the rest position, by reason of the safety light curtains, prevents the robot to start. In all other phases of processing, occupation of each light curtain causes the related robot to stop.

The related manual restart control is located close to each light curtain.

The system is equipped with four emergency push buttons (E-STOP).

Total safety devices: 2 safety light curtains - 2 restart buttons for the safety light curtains - 3 safety gate switches - 4 emergency push buttons.

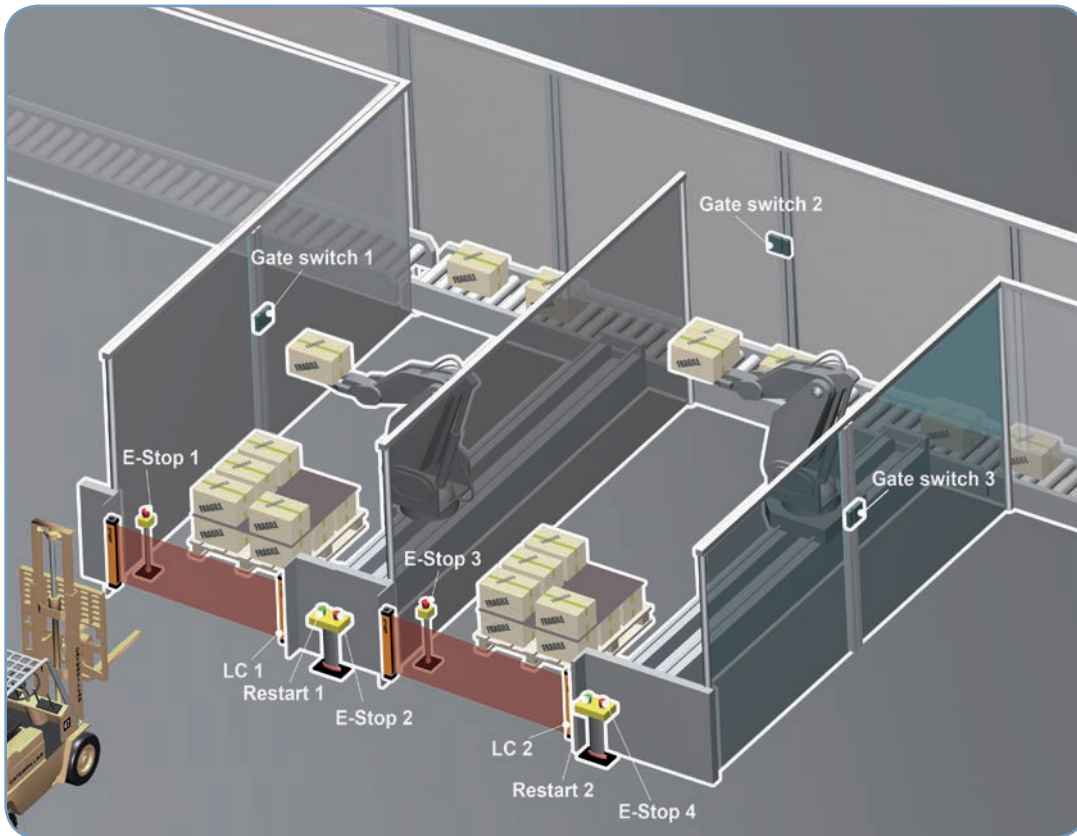

Using conventional components – safety relay modules – to build up the safety circuit, it would be necessary to use at least six safety modules, wired to each other in order to perform the required functions: 2 safety relays for the light curtains - 3 safety relays for the gate switches - 1 safety relay for the emergency stop.

### APPLICATION EXAMPLE 1 - SOLUTION WITH MOSAIC

Using Mosaic to build up the safety circuit, it is sufficient to use:

- 1 main unit M1
- 1 expansion unit MI802

which provide a total of:

- 16 inputs
- 4 OSSD pairs
- 8 test outputs
- 4 signal outputs.

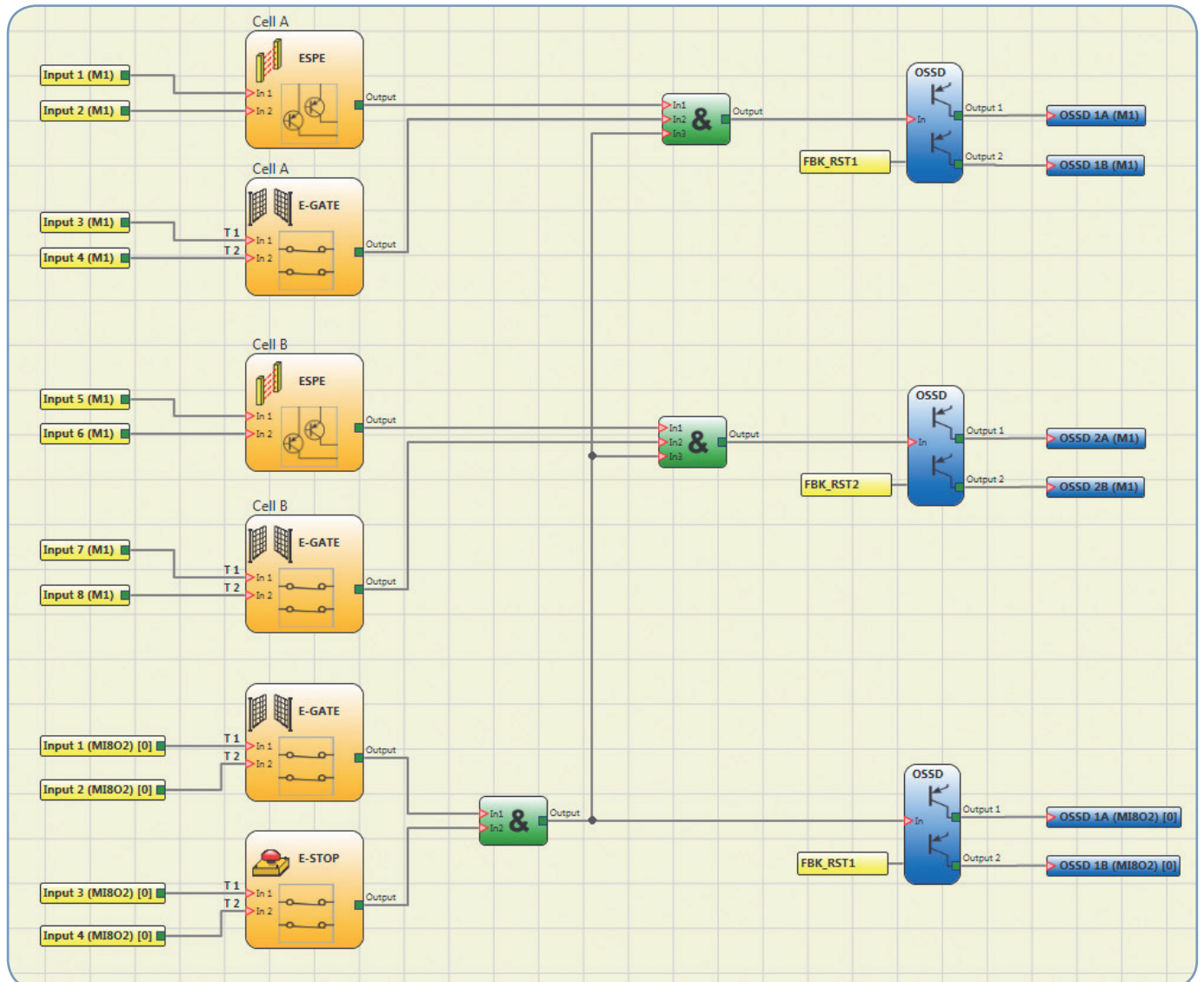

**Note:** The Reset buttons are not displayed on the diagram because they are directly connected to the feedback of the OSSD safety outputs (inputs FBK\_RST1, FBK\_RST2).

The 4 E-STOP are connected in series and are represented in the diagram with a single input block.

## APPLICATION EXAMPLE 2

### Safety management of a machining centre with alternate load / unload

The operator is required to load and unload the workpiece.

The machine is protected by two horizontal safety light curtains. In this case, each light curtain must be equipped with the muting function so as to permit access to the hazardous area by personnel during the non-hazardous part of the machine cycle.

Depending on the position of the tool, which is the hazardous element, one of the two light curtains (the one facing the tool working area) is active, while the other is muted so that the operator can load/unload the workpiece. The Muting condition of the two safety light curtains will then be inverted when the tool is required to operate on the opposite side of the machine.

The machine is completely protected by a fence with an access gate equipped with a safety switch. When the gate is opened, the machine stops.

The related manual restart control is located close to each safety light curtain. The system is equipped with three emergency push buttons which, if activated, stop the machine.

Total safety components: 2 safety light curtains - 2 restart buttons for the safety light curtains - 1 safety gate switch - 3 emergency push buttons.

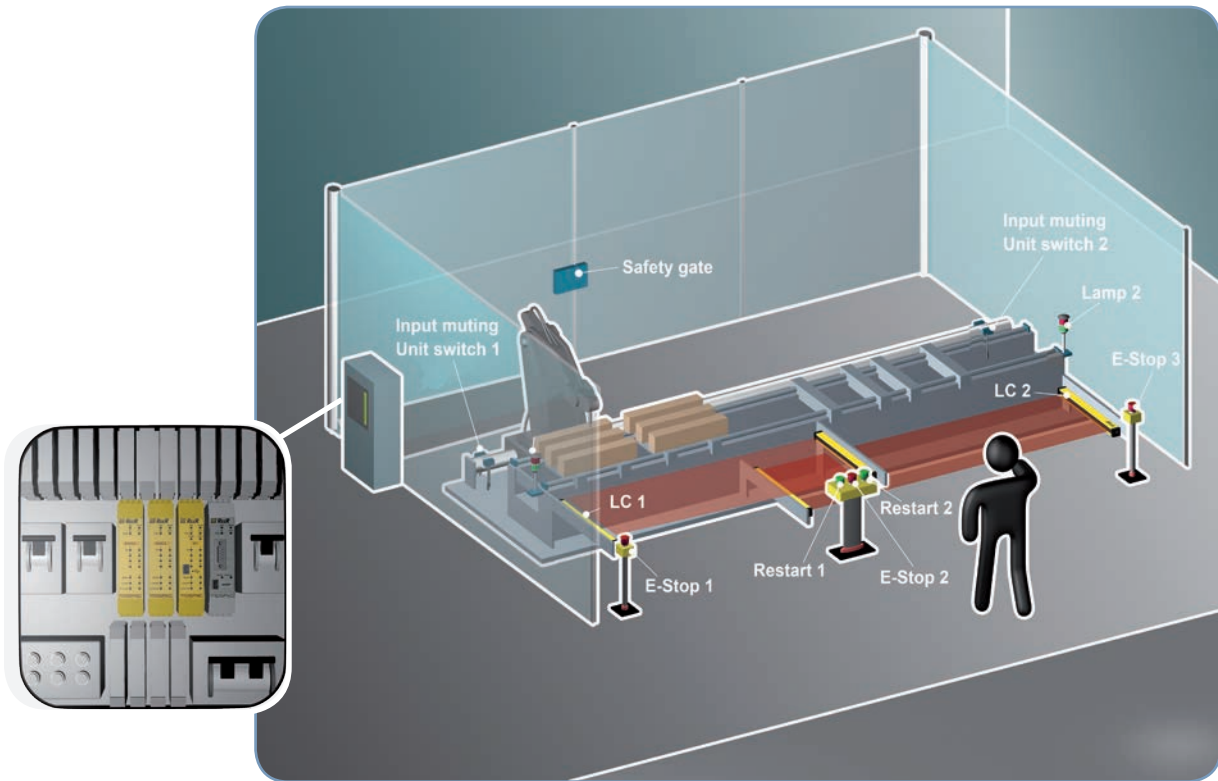

Using conventional components – safety relay modules – to build up the safety circuit, four safety modules would be necessary: 2 safety modules for the safety light curtains with muting function - 1 safety module for the gate switch - 1 safety module for the emergency stop.

## APPLICATION EXAMPLE 2 - SOLUTION WITH MOSAIC

Using Mosaic to build up the safety circuit, it is sufficient to use:

- 1 main unit M1
- 1 expansion unit MI8

Which provide a total of:

- 16 inputs
- 2 OSSD pairs
- 8 test outputs
- 2 signal outputs.

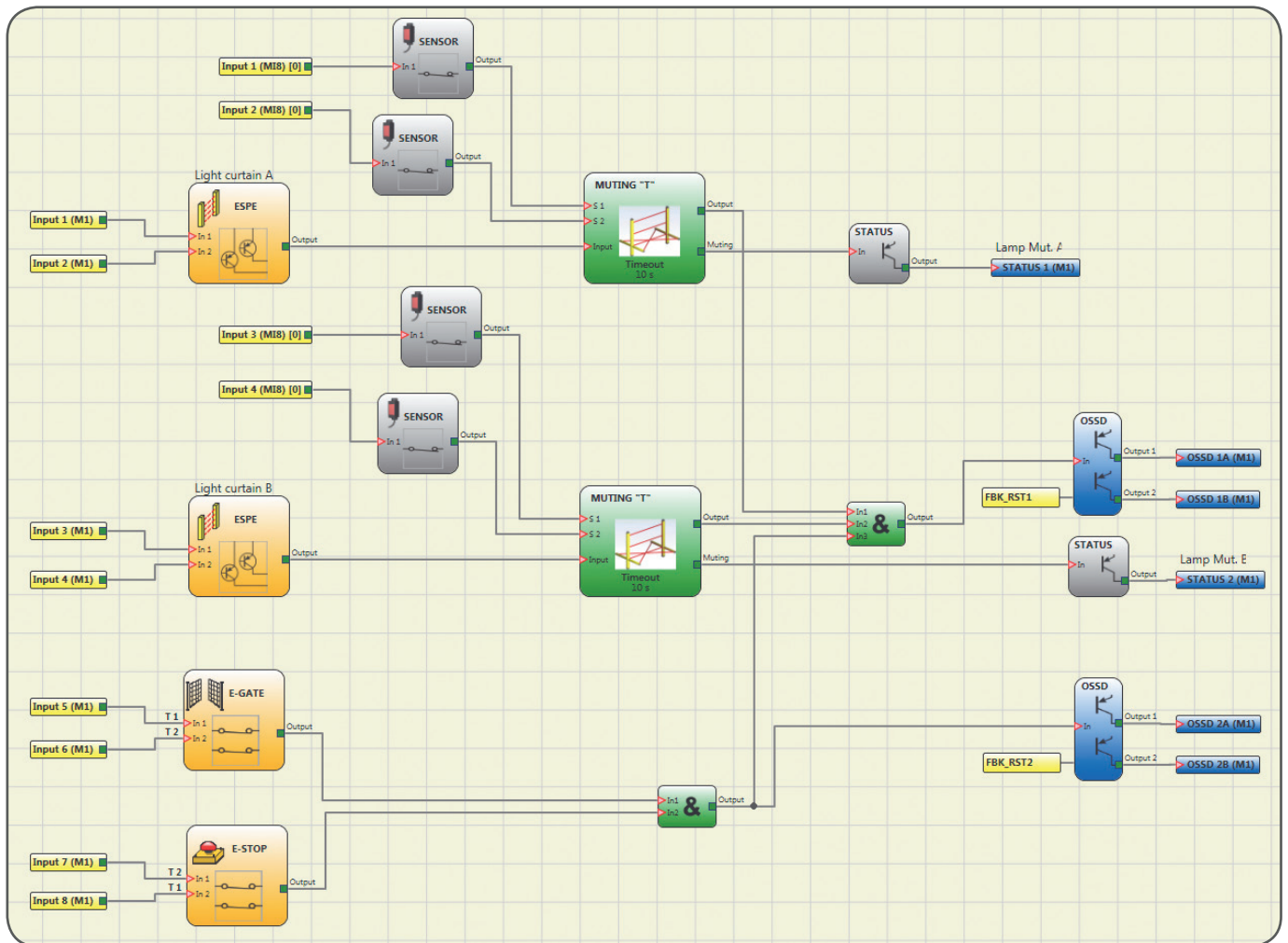

**Note:** The Reset buttons are not displayed on the diagram because they are directly connected to the feedback of the OSSD safety outputs (inputs FBK\_RST1, FBK\_RST2).

The 3 E-STOP are connected in series and are represented in the diagram with a single input block.

The diagram also shows the status of 2 outputs used to drive the indication lights of the active muting.



## APPLICATION EXAMPLE 3

### Speed monitoring for a hazardous tool

In this example the positioning of the workpiece is allowed only when the tool is completely stopped.

As long as the tool is working at the normal speed the GUARD LOCK is locked and the access to the hazardous area is not allowed.

Access to the hazardous area is allowed either when the working cycle is over or when the operator switches the MOD SEL to “Access Request”.

In the second case, the GARD LOCK is unlocked with a 4 seconds delay, that is the time needed to permit to the machine to completely stop the tool (time measured during the risk assessment). At this point the operator can safely access the hazardous area.

If the tool has to be kept moving for maintenance reasons as the operator is inside the hazardous area this is possible through the Grip Switch. The speed monitoring device detects whether the speed of the tool is under a defined threshold set through the MSD. If the threshold is exceeded or the Grip Switch is released the machine is immediately stopped.

Furthermore, during the working cycle the same speed monitoring device can detect when the speed of the tool is over a defined threshold and immediately stop the machine to avoid damages to the nearby operators and to the tool itself.

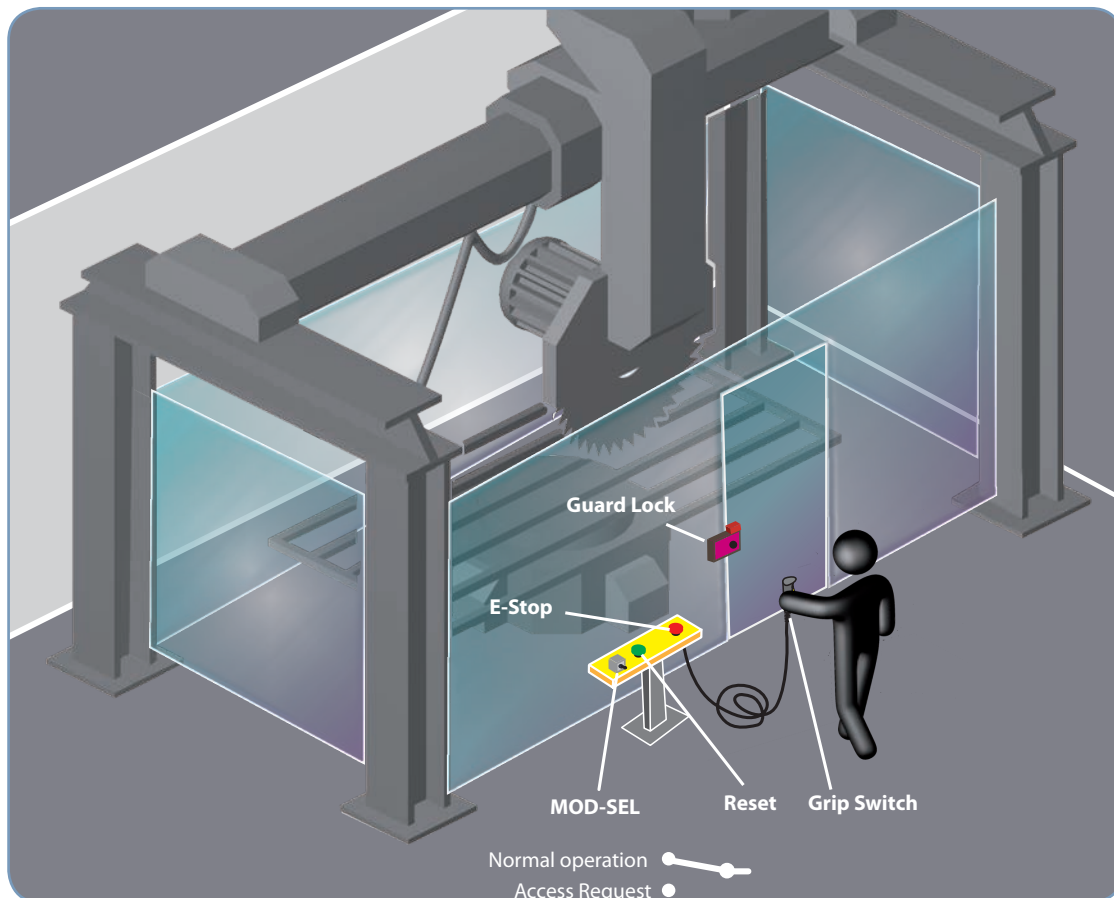

Using Mosaic to build up the safety circuit, it is sufficient to use:

- 1 main unit M1
- 1 expansion unit MI8
- 1 expansion unit MV1 for safety speed monitoring;

which provide a total of:

- 18 available inputs (24 usable inputs)
- 2 OSSD pairs
- 2 signal outputs.

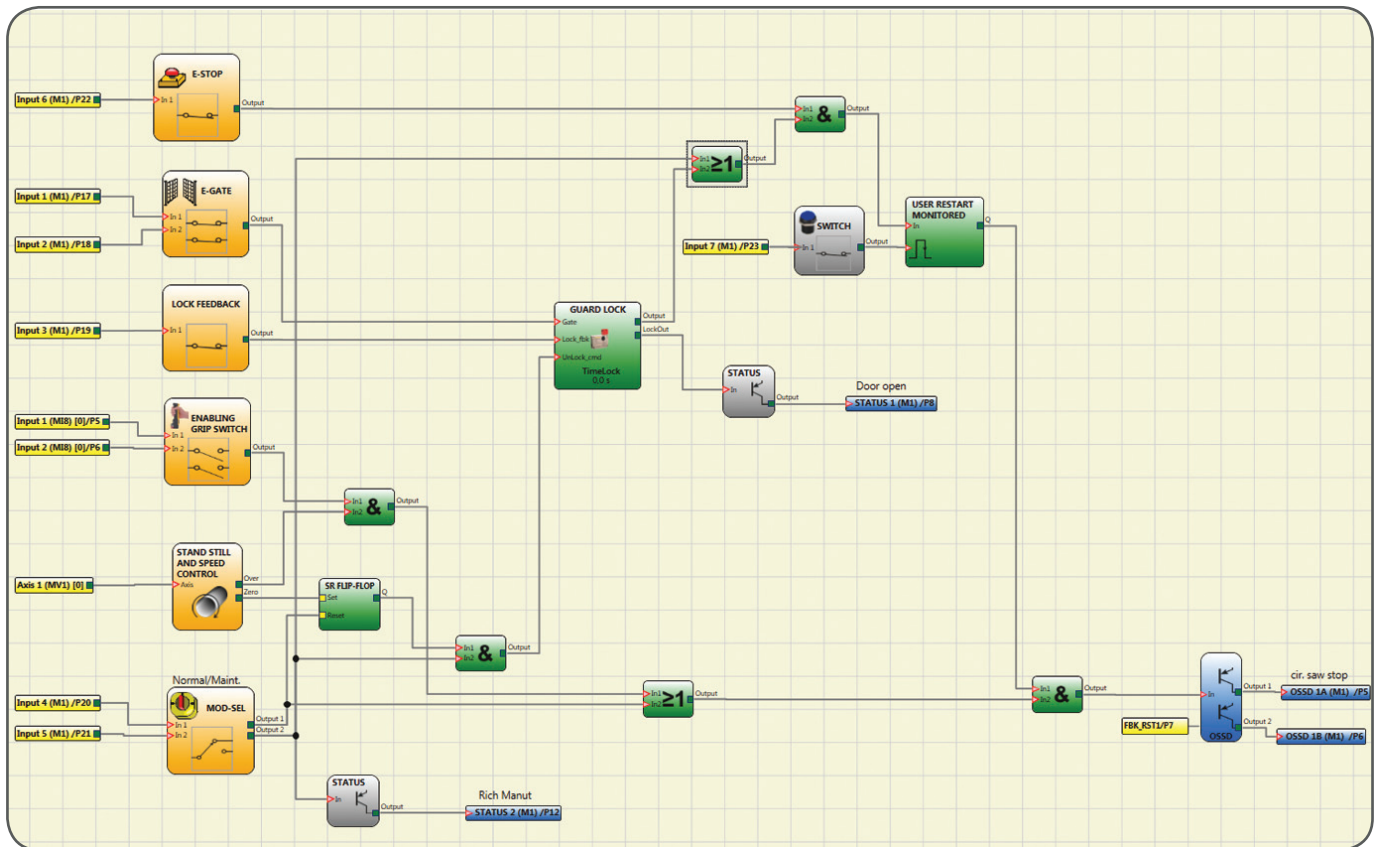

**Comments:**

Using MOSAIC, all the safety logic circuitry is implemented using the graphic interface and not by hard-wiring the outputs of the relay modules to each other. Correct functioning of the logic circuitry is checked during the design phase by the VALIDATION function and can be tested with the MONITOR function during installation.

During the design phase, safety functions can be easily added or removed, for example adding other sensors or zones. Start up tests can be inserted in order to detect any attempt of by-passing the safety system, which is always a possibility with traditional relay modules.

The two-level password provides protection against unauthorised modification of system configuration.

**Conclusions:**

The three examples have been intentionally simplified. In reality, it is often necessary to implement a great number of functions such as delays, filters or more complex safety logics that combine signals from several sources.

This would entail the use of numerous relay modules, thereby further complicating implementation of the logic circuitry, wiring and final cost.

MOSAIC provides designers with all the logical safety functions and these can be immediately combined using only the MSD graphic interface.



# SAFECODER

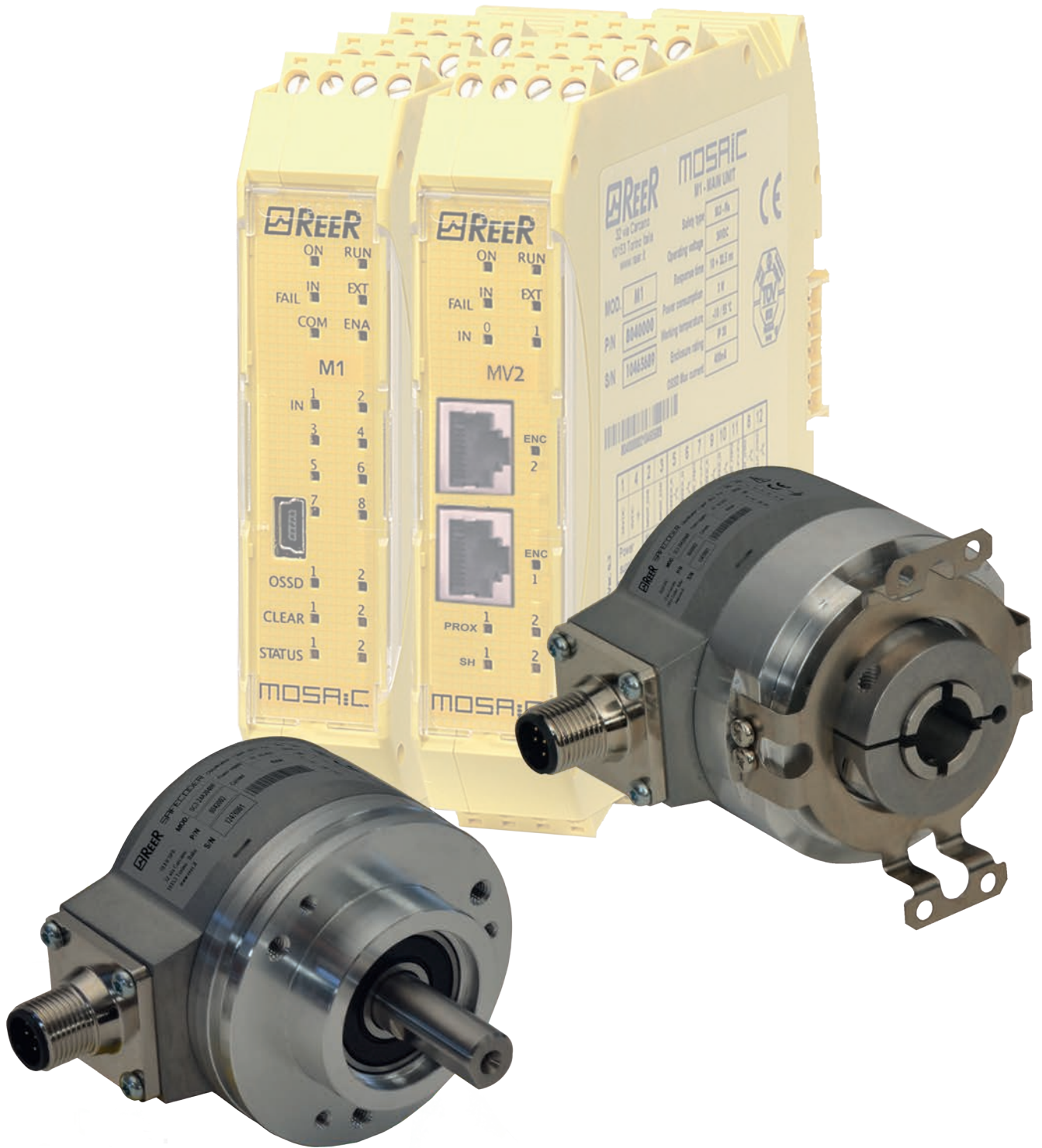

# SAFECODER

## GENERAL

The safety Sin/Cos incremental encoder SAFECODER, together with Mosaic, comprise a SIL 3 certified safety function for speed monitoring. SAFECODER encoders are characterized by robust and reliable interface and the ability to handle high mechanical loads and electronic equipment.

## MAIN CHARACTERISTICS

Incremental encoder for use in safety-related applications up to SIL3.

Shaft or Hollow Shaft versions.

Protection rate: housing and flange side IP67, shaft IP65 (optional IP67)

Safety-Lock™.

Allow high rotational speed and high shaft load capacity

Shock and vibration resistant.

Insensitive to strong magnetic fields.

2048 pulse rate.



Shaft version



Hollow Shaft version

## TECHNICAL DATA AND ORDERING CODES

Model	SC3 24D2048R	SC3 05D2048R	SC3 24B2048R	SC3 05B2048R
Ordering code	1100102	1100103	1100104	1100105
Power supply	24 VDC	5 VDC	24 VDC	5 VDC
Shaft type	Hollow Shaft version Ø 12 mm		Shaft version Ø 10 mm with flat	
Resolution	2048 pulse rate		2048 pulse rate	
Connector	Radial M12		Radial M12	

## Cables

Model	Code	Description
C8D5 SH	1330930	M12 straight connector, 8 poles, pre-wired shielded cable 5 m
C8D10 SH	1330931	M12 straight connector, 8 poles, pre-wired shielded cable 10 m
C8D15 SH	1330932	M12 straight connector, 8 poles, pre-wired shielded cable 15 m
C8D95 SH	1330933	M12 90° angled connector, 8 poles, pre-wired shielded cable 5 m
C8D910 SH	1330934	M12 90° angled connector, 8 poles, pre-wired shielded cable 10 m
C8D915 SH	1330935	M12 90° angled connector, 8 poles, pre-wired shielded cable 15 m

Cable supplied with M12 8-pole connector at one end only. The other side must be cut off at correct length and crimped with RJ45 connector (not included).

## Safety level: SIL 3 – SILCL 3 – PL e – Cat. 4 – Type 4

- 2006/42/EC “Machinery Directive”
- 2004/108/EC “Electromagnetic Compatibility (EMC)”
- EN ISO 13849-1 “Safety of machinery: Safety-related parts of control systems. Part 1: General principles for design”.
- EN ISO 13849-2 “Safety of machinery: Safety-related parts of control systems. Part 2: Validation”
- IEC 61508 “Functional safety of electrical, electronic and programmable electronic safety-related systems.
- EN ISO 61800-5-2 “Adjustable speed electrical power drive systems”. Part 5-2 Safety requirements - Functional
- UL (C+US) mark for USA and Canada
- BGIA - Institute for Occupational Safety and Health - Germany.



Safety level:

**SIL 3**

SIL 3 – SILCL 3  
PL e – Cat. 4

## SAFETY SPEED MONITORING INTERFACE



# SV MRO

## PL e - SIL 3 SAFETY SPEED MONITORING INTERFACE

### GENERAL

Safety speed monitoring relay for Overspeed and Zero speed control. Safety level up to PL e - SIL 3. Manual or Automatic restart selectable.

EDM feedback input for external contactors monitoring.

Enable inputs used, for instance, when monitoring the same axis, in different working phases, with more SV MRO configured with different thresholds.

Faults are signalled by LED "Fault" and a PNP system status output.

PNP status output indicating overspeed thresholds crossing.

2 inputs for PNP proximities switches.

3 front panel selectors allow configuration of the speed threshold. When the measured speed raises over the threshold, the relays outputs open.

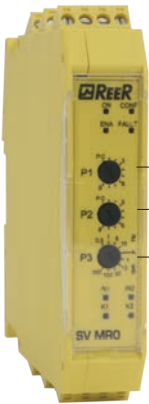

Speed threshold configuring selectors:

- P1 selector tenths
- P2 selector units
- P3 selector multiplier

P1 and P2 selectors allow to set numeric values from 01 to 99. P2 selector allows to set a multiplier to apply to the numeric value obtained with the first two. The multiplier can be set in "Hz" or in "rpm" (round per minute). Note: Only when the proximities switches sensor show a single pulse per turn, the value in "rpm" corresponds to the value in "ipm" (pulse per minute).

#### Multipliers "Hz" from 0.5 to 990 Hz

- 1 - x 0.5
- 2 - x 1
- 3 - x 5
- 4 - x 10

#### Multipliers "rpm" From 1 to 49,500 rpm

- 1 - x 1
  - 2 - x 10
  - 3 - x 50
  - 4 - x 100
  - 5 - x 500
- Note: minimum possible value 10 rpm

### TECHNICAL DATA

<b>Model</b>	<b>SV MRO</b>
<b>Ordering Code</b>	<b>1100078</b>
<b>Safety level</b>	up to PL e, Cat. 4 according to EN ISO 13849-1 SIL 3 - SILCL 3 according to IEC 61508 - IEC 62061
<b>Safety relay outputs</b>	2 NO - 6A 250 VAC
<b>Overspeed status output</b>	PNP - 100 mA 24 VDC
<b>System status output</b>	PNP - 100 mA 24 VDC
<b>Power supply</b>	24 VDC ± 20%
<b>Electrical connections</b>	Removable terminal blocks, screw contacts
<b>Start/Restart</b>	Automatic/Manual
<b>Maximum input Frequency (Hz)</b>	2000
<b>Selectable Frequency Threshold (Hz)</b>	0,5 ... 990
<b>Selectable Frequency Threshold (rpm)</b>	10 ... 49500 equivalent to 0,17 ... 825 Hz
<b>Hysteresis</b>	5%
<b>External Device Monitoring</b>	yes
<b>Signalling</b>	LED indicators for status and diagnostic
<b>Protection rating</b>	IP 20 for housing - IP 2X for terminal block
<b>Operating temperature</b>	-40 ... +55 °C
<b>Fastening</b>	DIN rail fastening according to EN 50022-35 standard
<b>Dimensions h x w x d (mm)</b>	99 x 22,5 x 114



**-40 ... +55 °C**



Safety level:

**SIL 3**

**SIL 3 – SILCL 3  
PL e – Cat. 4**

### Safety level: **SIL 3 – SILCL 3 – PL e – Cat. 4**

- 2006/42/EC "Machinery Directive"
- 2004/108/EC " Electromagnetic Compatibility (EMC) "
- 2006/95/EC "Low Voltage Directive (LVD) "
- EN ISO 13849-1 "Safety of machinery – Safety-related parts of control systems – Part 1: General principles for design"
- IEC/EN 62061 "Safety of machinery – Functional safety of safety-related electrical, electronic and programmable electronic control systems"
- IEC 61508 "Functional safety of electrical/electronic/programmable electronic safety-related systems"

## SAFETY INTERFACES AND RELAYS





# AD SR1

## TYPE 4 INTERFACE FOR LIGHT CURTAINS

### MAIN FEATURES

Interface module between the safety light curtains EOS4 A, EOS2 A, Admiral AD, Admiral AX BK, Vision V with self-testing solid state safety outputs, and the machine control circuits.

With guided-contact safety relays, 2 NO contacts and PNP output for relay status signaling.

Start/Restart interlock.

EDM Feedback input for extra external contactors monitoring.



### TECHNICAL FEATURES

Model	<b>AD SR1</b>
Ordering code	<b>1330900</b>
Safety level	Type 4 according to IEC/TS 61496-2 SIL 3 – SILCL 3 according to IEC 61508 - IEC 62061 PL e – Cat. 4 according to ISO 13849-1
Two-channel inputs for safety light curtains	1
Safety relay outputs	2 NO - 2 A 250 VAC
Status output	PNP – 100 mA at 24 VDC
Response time (ms)	≤ 20
Start/Restart command according to IEC 61496-1	manual or automatic Start/Restart selectable on terminal block
External Device Monitoring	external relay control feedback input, selectable
Signalling	LED indication of input/output status and diagnosis
Power supply (VDC)	24 ± 20%
Electrical connections	on terminal blocks
Operating temperature (°C)	0 ... 55
Protection rating	IP 20 for housing - IP 2X for terminal blocks
Fastening	DIN rail fastening according to EN 50022-35 standard
Dimensions h x w x d (mm)	99 x 22,5 x 114

### ORDERING INFORMATION

Each AD SR1 safety interface includes multi-language instruction manual complete with CE declaration of conformity

### Safety level: **Type 4 – SIL 3 – SILCL 3 – PL e – Cat. 4**

- 2006/42/EC “Machinery Directive”
- 2004/108/EC “ Electromagnetic Compatibility (EMC)”
- 2006/95/EC “Low Voltage Directive (LVD)”
- IEC/EN 61496-1 Ed. 2.1 and IEC/TS 61496-2 Ed. 2 “ Safety of machinery - Electro-sensitive protective equipment - General requirements and tests”
- EN ISO 13849-1 “Safety of machinery – Safety-related parts of control systems – Part 1: General principles for design”
- IEC/EN 62061 “Safety of machinery – Functional safety of safety-related electrical, electronic and programmable electronic control systems”
- IEC 61508 “Functional safety of electrical/electronic/programmable electronic safety-related systems”
- IEC/TS 62046 Ed. 2 “Safety of machinery – Application of protective equipment to detect the presence of persons”
- UL (C+US) mark for USA and Canada.



#### MAIN FEATURES

Interface module between the safety light curtains EOS4, EOS2, Admiral, Vision (any resolution and heights), the safety laser PHARO and the machine control circuits, with 2-sensor logic integrated Muting.

With guided contact safety relays, 2 NO contacts and PNP output for relay status signaling.

Start/Restart interlock.

EDM Feedback input for extra external contactors monitoring.

Muting Time-out selectable.

Integrated Override with 2 operating modes selectable.

Muting Enable input.



#### TECHNICAL FEATURES

Model	<b>AD SRM</b>
Ordering code	<b>1330904</b>
Safety level	Type 4 according to IEC/TS 61496-2 SIL 3 – SILCL 3 according to IEC 61508 - IEC 62061 PL e – Cat. 4 according to ISO 13849-1
Two-channel inputs for safety light curtains	1
Inputs for Muting sensors	2 inputs 0 or 24 VDC – PNP or relay – dark-on
Muting Enable input	0 or 24 VDC – PNP or relay
Safety relay outputs	2 NO - 2A 250 VAC
Status output	PNP – 100 mA at 24 VDC
Muting lamp output	24 VDC; 0,5 ... 5 W
Response time (ms)	≤ 20
Start/Restart command according to IEC 61496-1	manual or automatic Start/Restart selectable on terminal block
External Device Monitoring	external relay control feedback input, selectable
Signalling	LED indications of input/output status, Muting sensor inputs, diagnosis
Muting time-out	30 sec. or infinite, selectable
Override	2 operating modes selectable: - manual action with hold to run - automatic with pulse command
Override time-out min	15.
Power supply (VDC)	24 ± 20%
Electrical connections	On terminal block
Operating temperature (°C)	0 ... 55
Protection rating	IP 20 for housing - IP 2X for terminal block
Fastening	DIN rail fastening according to EN 50022-35 standard
Dimensions h x w x d (mm)	99 x 35 x 114

#### ORDERING INFORMATION

Each AD SRM safety interface includes multi-language instruction manual complete with CE declaration of conformity

Safety Level:

# TYPE 4

**SIL 3 – SILCL 3  
PL e – Cat. 4**

# AD SRT

## PL e SAFETY INTERFACE FOR TWO-HAND CONTROL

### MAIN FEATURES

Safety relays for two-hand control.

With 2 NO + 1 NC guided-contact safety relays.

EDM Feedback input for external contactors monitoring.

The AD SRT can be used up to Cat. 4, PL e.

It is certified as Type III C according to the EN 574 standard and monitors the simultaneity between the two inputs (< 0.5 sec).



### TECHNICAL FEATURES

Model	AD SRT
Ordering code	1330915
Safety level	PL e, Cat. 4 according to ISO 13849-1
input for two-hand control unit	input with 3 or 4 contacts
Safety relay outputs	2 NO + 1 NC – 6 A 240 VAC / 24 VDC Each NO safety output line is interrupted twice by the two relays
Response time (ms)	≤ 30
External Device Monitoring	yes
Signalling	LED indicators for status and supply diagnostic: power, channel 1 and channel 2
Power supply (VDC)	24 (-15 +10%)
Electrical connection	on terminal block
Operating temperature (°C)	- 25 ... 55
Protection rating	IP 40 for housing - IP 20 for terminal block
Fastening	DIN rail fastening according to EN 50022-35 standard
Dimensions h x w x d (mm)	99 x 22,5 x 114

### ORDERING INFORMATION

Each AD SRT safety relay includes multi-language instruction manual complete with CE declaration of conformity

Safety level:

**PL e**

**Cat. 4  
Type III C (EN 574)**

### Safety level: PL e – Cat. 4 – Type III (EN 574)

- 2006/42/EC “Machinery Directive”
- 2004/108/EC “ Electromagnetic Compatibility (EMC)”
- 2006/95/EC “Low Voltage Directive (LVD)”
- EN ISO 13849-1 “Safety of machinery – Safety-related parts of control systems – Part 1: General principles for design”
- UL (C+US) mark for USA and Canada.



## AD SRE4 – AD SRE4C

### PL e SAFETY INTERFACES FOR EMERGENCY STOP BUTTONS AND SAFETY SWITCHES

#### MAIN FEATURES

Safety relays for monitoring emergency stop buttons, safety switches.

With 3 NO + 1 NC guided-contact safety relays.

The Start/Restart can be either Automatic/Manual with the AD SRE4 or Manual Monitored with the AD SRE4C.

EDM Feedback input for external contactors monitoring.

Both models can be used up to safety category 4, PL e according to EN ISO 13849-1.



#### TECHNICAL FEATURES

Model	AD SRE 4	AD SRE 4C
Ordering code	1330913	1330914
Safety level	up to PL e, Cat. 4 according to EN ISO 13849-1	
Safety relay outputs	3 NO + 1 NC – 5 A 240 VAC / 24 VDC Each NO safety output line is interrupted twice by the two relays	
Response time (ms)	≤ 50	
Start/Restart	Automatic/Manual	Manual - Monitored
External Device Monitoring	Yes	
Signalling	LED indicators for status and supply diagnostic: power, channel 1 and channel 2	
Power supply (VDC)	24 (±10%)	
Electrical connection	on terminal block	
Operating temperature (°C)	- 25 ... 55	
Protection rating	IP 40 for housing - IP 20 for terminal block	
Fastening	DIN rail fastening according to EN 50022-35 standard	
Dimensions h x w x d (mm)	99 x 22,5 x 114	

#### ORDERING INFORMATION

Each AD SRE4 and AD SRE4C safety relay includes multi-language instruction manual complete with CE declaration of conformity

Safety level:

# PL e

PL e – Cat. 4

#### Safety level: PL e – Cat. 4

- 2006/42/EC “Machinery Directive”
- 2004/108/EC “ Electromagnetic Compatibility (EMC)”
- 2006/95/EC “Low Voltage Directive (LVD)”
- EN ISO 13849-1 “Safety of machinery – Safety-related parts of control systems – Part 1: General principles for design”
- UL (C+US) mark for USA and Canada.



## AD SRE3 – AD SRE3C

PL d SAFETY INTERFACES FOR EMERGENCY STOP BUTTONS AND SAFETY SWITCHES

### MAIN FEATURES

Safety relays for monitoring emergency stop buttons, safety switches.

With 2 NO + 1 NC guided-contact safety relays.

The Start/Restart can be either Automatic/Manual with the AD SRE3 or Manual Monitored with the AD SRE3C.

EDM Feedback input for external contactors monitoring.

Both models can be used up to safety category 3, PL d according to EN ISO 13849-1.



### TECHNICAL FEATURES

Model	AD SRE 3	AD SRE 3C
Ordering code	1330911	1330912
Safety level	up to PL d, Cat. 3 according to EN ISO 13849-1	
Safety relay outputs	2 NO – 6 A 240 VAC / 24 VDC Each NO safety output line is interrupted twice by the two relays	
Response time (ms)	≤ 50	
Start/Restart command according to IEC 61496-1	Automatic/Manual	Manual - Monitored
External Device Monitoring	yes	
Signalling	LED indicators for status and supply diagnostic: power, channel 1 and channel 2	
Power supply (VDC)	24 (-15 +10%)	
Electrical connection	on terminal block	
Operating temperature (°C)	- 25 ... 55	
Protection rating	IP 40 for housing - IP 20 for terminal block	
Fastening	DIN rail fastening according to EN 50022-35 standard	
Dimensions h x w x d (mm)	99 x 22,5 x 114	

### ORDERING INFORMATION

Each AD SRE3 and AD SRE3C safety relay includes multi-language instruction manual complete with CE declaration of conformity

Safety level:

**PL d**

**Cat. 3**

### Safety level: PL d - Cat. 3

- 2006/42/EC "Machinery Directive"
- 2004/108/EC " Electromagnetic Compatibility (EMC)"
- 2006/95/EC "Low Voltage Directive (LVD)"
- EN ISO 13849-1 "Safety of machinery – Safety-related parts of control systems – Part 1: General principles for design"
- UL (C+US) mark for USA and Canada.



**MAIN FEATURES**

MG d1 is a safety control unit for monitoring up to 8 Magnus safety switches in series

With 1 safety switch connected reach the PLd safety level

With up to 4 safety switch connected reach the PLc safety level

▶ see page 159

It features a two positively mechanically linked contacts and EDM (External Device Monitoring).



**TECHNICAL FEATURES**

<b>Model</b>	<b>MG d1</b>
<b>Ordering code</b>	<b>1291050</b>
<b>Safety level</b>	up to PL d – SILCL 2
<b>Safety relay outputs</b>	2 NO – 3 A – 250 VAC Each NO safety output line is interrupted twice by the two relays
<b>Response time (ms)</b>	< 20
<b>External Device Monitoring</b>	yes
<b>Signalling</b>	LED indicators for status and diagnostic
<b>Power supply (VDC)</b>	24 (±10%)
<b>Electrical connection</b>	on terminal block
<b>Operating temperature (°C)</b>	0 ... 55
<b>Protection rating</b>	IP 40 for housing - IP 2X for terminal block
<b>Fastening</b>	DIN rail fastening according to EN 50022-35 standard
<b>Dimensions h x w x d (mm)</b>	75 x 25 x 94

**ORDERING INFORMATION**

Each AD SRT module includes multi-language instruction manual complete with CE declaration of conformity

Safety level:

**PL d**

**SILCL 2 - Cat. 3**

**Safety level: PL d - SILCL 2 - Cat. 3**

- 2006/42/EC “Machinery Directive”
- 2004/108/EC “ Electromagnetic Compatibility (EMC)”
- 2006/95/EC “Low Voltage Directive (LVD)”
- EN ISO 13849-1 “Safety of machinery – Safety-related parts of control systems – Part 1: General principles for design”
- IEC/EN 62061 “Safety of machinery – Functional safety of safety-related electrical, electronic and programmable electronic control systems”
- IEC 61508 “Functional safety of electrical/electronic/programmable electronic safety-related systems”.



## AU SX

### TYPE 2 CONTROL UNIT FOR ILION AND ULISSE PHOTOCELLS

#### MAIN FEATURES

Control unit for safety photocells ILION and ULISSE, which can be combined to form a Type 2 safety system.

Up to 4 photocells may be connected.

With guided-contact safety relays, 2 NO contacts and PNP output for status signalling.

Start/Restart interlock.

EDM Feedback input for external contactors monitoring.

Self test every 5 seconds.



#### TECHNICAL FEATURES

Model	AU SX
Ordering code	1201710
Safety level	Type 2 according to IEC/TS 61496-2 SIL 2 – SILCL 2 according to IEC 61508 - IEC 62061 PL d – Cat. 2 according to ISO 13849-1
Number of photocells	1 ... 4
Safety relay outputs	2 NO - 2 A 250 VAC
Status output	PNP - 100 mA at 24 VDC
Response time (ms)	≤ 30
Start/Restart command according to IEC 61496-1	manual or automatic Start/Restart selectable on terminal block
External Device Monitoring	external relay control feedback input, selectable
Signalling	LED indication of input/output status and diagnosis
Power supply (VDC)	24 ± 20%
Electrical connections	on terminal block
Operating temperature (°C)	0 ... 55
Protection rating	IP 20 for housing - IP 2X for terminal block
Fastening	DIN rail fastening according to EN 50022-35 standard
Dimensions h x w x d (mm)	99 x 22,5 x 114

#### ORDERING INFORMATION

Each AU SX module includes multi-language instruction manual complete with CE declaration of conformity

#### Safety level: Type 2 – SIL 2 - SILCL 2 - PL d - Cat. 2

(with ILION or ULISSE photocells)

- 2006/42/EC “Machinery Directive”
- 2004/108/EC “ Electromagnetic Compatibility (EMC)”
- 2006/95/EC “Low Voltage Directive (LVD)”
- IEC/EN 61496-1 Ed. 2.1 and IEC/TS 61496-2 Ed. 2 “ Safety of machinery - Electro-sensitive protective equipment
- EN ISO 13849-1 “Safety of machinery – Safety-related parts of control systems – Part 1: General principles for design”
- IEC/EN 62061 “Safety of machinery – Functional safety of safety-related electrical, electronic and programmable electronic control systems”
- IEC 61508 “Functional safety of electrical/electronic/programmable electronic safety-related systems”
- IEC/TS 62046 Ed. 2 “Safety of machinery – Application of protective equipment to detect the presence of persons”
- UL (C+US) mark for USA and Canada.



#### MAIN FEATURES

AU SXM control unit, with integrated Muting functions, for safety photocells ILION and ULISSE, which can be combined to form a Type 2 safety system. Up to 4 photocells may be connected.

- 2-sensor Muting logics.
- Muting Time-out selectable.
- Integrated Override with selectable 2-mode operation.
- Muting Enable input.

- Start/Restart interlock.
- EDM Feedback input for extra external contactors monitoring.

Self test every 5 seconds.



#### TECHNICAL FEATURES

Model	<b>AU SXM</b>
Ordering code	<b>1201711</b>
Safety level	Type 2 according to IEC/TS 61496-2 SIL 2 – SILCL 2 according to IEC 61508 - IEC 62061 PL d – Cat. 2 according to ISO 13849-1
Number of photocells	1 ... 4
Inputs for Muting sensors	2 inputs 0 or 24 VDC – PNP or relay – dark-on
Muting Enable input	0 or 24 VDC – PNP or relay
Safety relay outputs	2 NO - 2A 250 VAC
Status output	PNP - 100 mA at 24 VDC
Muting lamp output	24 VDC; 0,5 - 5 W
Muting time-out	30 sec. or infinite, selectable
Override	2 operating modes selectable: manual action with hold to run or automatic with pulse command
Override time-out (min)	15
Response time (ms)	≤ 30
Start/Restart command according to IEC 61496-1	manual or automatic Start/Restart selectable on terminal block
External Device Monitoring	external relay control feedback input, selectable
Signalling	LED indications of input/output status, Muting sensor inputs, diagnosis
Power supply (VDC)	24 ± 20%
Electrical connections	on terminal blocks
Operating temperature (°C)	0 ... 55
Protection rating	IP 20 for housing - IP 2X for terminal blocks
Fastening	DIN rail fastening according to EN 50022-35 standard
Dimensions h x w x d (mm)	99 x 35 x 114

#### ORDERING INFORMATION

Each AU SXM module includes multi-language instruction manual complete with CE declaration of conformity

Safety level:

# TYPE 2

**SIL 2 – SILCL 2**  
**PL d – Cat. 2**



## AD SRO – AD SROA

SAFETY RELAY MODULES FOR DEVICES WITH INTEGRATED FEEDBACK INPUT FOR EDM

### MAIN FEATURES

Interface relay modules for safety light curtains with feedback input for EDM, such as EOS4 X, Admiral AX, EOS2 X, Vision VX/VXL/MXL and Janus.

With guided-contact safety relays, 2 NO + 1 NC (AD SRO) or 2 NO contacts (AD SROA).

Additional NC contact line for the monitoring by light curtain (EDM).



### TECHNICAL FEATURES

Model	AD SRO	AD SROA
Ordering code	1330902	1330903
Safety relay outputs	2 NO + 1 NC- 2 A 250 VAC Each NO safety output line is interrupted twice by the two relays	2 NO - 2 A 250 VAC
Response time (ms)	≤ 20	
Power supply (VDC)	24 ± 20%	
Electrical connections	on terminal block	
Operating temperature (°C)	0 ... 55	
Protection rating	IP 20 for housing - IP 2X for terminal block	
Fastening	DIN rail fastening according to EN 50022-35 standard	
Dimensions h x w x d (mm)	101 x 35 x 120	

### ORDERING INFORMATION

Each AD SRO and AD SROA module includes multi-language instruction manual complete with CE declaration of conformity



### WARNING!

AD SRO and AD SROA modules can only be connected to safety sensors equipped with feedback input for monitoring external relays (EDM): EOS4 X, EOS2 X, Janus, Admiral AX (excluding AX BK models with Blanking), Pharo and Vision VX, VXL and MXL ranges.

Please contact Reer for any other type of application.



# WATERTIGHT ENCLOSURES



## EOS4 and EOS2 WTF and WTHF versions IP 69K WATERTIGHT ENCLOSURE, WITH OR WITHOUT HEATING SYSTEM

### MAIN CHARACTERISTICS

Watertight enclosures allow light curtains and light grids to be used in a harsh working environments with exposure to water and steam.

Thanks to its inert (non-toxic) components, no residuals are left when the light curtains are washed down or when they come directly in contact with food. This makes WTF and WTHF enclosures suitable for the Food & Beverage industry.

The watertight enclosure is made of:

- PMMA (polymethyl methacrylate) transparent enclosure
- POM-C (acetal resin – DELRIN®) sealing caps
- Anti-condensation system through integrated GORE™ valve
- POM-C and Stainless steel fastening brackets (AISI 316L)

The small EOS WTF and WTHF cylindrical enclosure (only 56mm diameter) is IP 69K protection rate tested and can withstand up to 80 bar of water jets pressure at the temperature of 80°C.

Enclosure incorporates a valve to drain humidity and avoid condensation.

WTHF version (Heated) has a thermostatically-controlled heating system and can work down to – 25° C.

#### Available models:

##### EOS4 X WTF/WTHF

protected height 160 ... 1810 mm and 2, 3, 4 beams  
resolution 14 mm, Max. range 5 m  
resolution 30 mm and 2, 3, 4 beams, Max. range 17 m

► [EOS4 technical features can be found at page 61](#)

##### EOS2 X WTF/WTHF

protected height 160 ... 1810 mm and 2, 3, 4 beams  
resolution 30 mm and 2, 3, 4 beams, Max. range 10 m

► [EOS2 technical features can be found at page 126](#)

The safety light curtain/grid is delivered already enclosed into its watertight tube with a 10m long prewired cable and the related fastening brackets.



### TECHNICAL FEATURES

Model		WTF	WTHF
<b>Protection rating</b>		IP 69K	
<b>Operating temperature (°C)</b>		0 ... 55	- 25 ... 50
<b>Max. water pressure jets</b>		80 ... 100 bar at 80° C (± 5° C)	
<b>Max. range (m)</b>	<b>EOS4 X (14 mm resolution)</b>	2 or 5 selectable	
<b>Max. range (m)</b>	<b>EOS4 XH</b>	8 or 17 selectable	
<b>Max. range (m)</b>	<b>EOS2</b>	3 or 10 selectable	
<b>Resolution (mm)</b>	<b>EOS4</b>	14, 30	
<b>Resolution (mm)</b>	<b>EOS2</b>	30	
<b>Nr. Beams</b>	<b>EOS4, EOS2</b>	2, 3, 4	
<b>Protected height (mm)</b>	<b>EOS4, EOS2</b>	160 ... 1810	
<b>Electrical connections</b>		10-metre cable pre-wired with cable gland	
<b>WTHF heated power consumption</b>		-	24 VDC - 20 W x Protected height (m)
<b>Fastening mode</b>		2 x M6 stainless steel screws (not included)	

## EOS4 and EOS2 WTF and WTHF versions IP 69K WATERTIGHT ENCLOSURE, WITH OR WITHOUT HEATING SYSTEM

### Test procedure: Ecolab-test F&E Nr. 40-1

Material resistance test according to cleaning procedures for food and beverage industry.

- **Dipping test** - Complete immersion in solution/liquid, Test Period: 28 days.
- **Rinsing with water 40 – 50°C** - Rinsing with low pressure. Rinsing from top to bottom in the direction of the drains
- **Cleaning of the drains**
- **Foaming from bottom to top** - Alkaline: P3-topax 66 - Acid: P3-topax 56 - Temperature: cold up to 40 °C - Contact time: 15 min. recommended
- **Rinsing with water 40 – 50°C** - Rinsing from top to bottom with low pressure
- **Disinfection** - P3-topactive DES 1-3% 10-30 min.

### EOS4 WTF and WTHF MODELS

#### Models X resolution 14 mm - max range: 5 m

 Resolution 14 mm	EOS4 151 X WTF	EOS4 301 X WTF	EOS4 451 X WTF	EOS4 601 X WTF	EOS4 751 X WTF	EOS4 901 X WTF	EOS4 1051 X WTF	EOS4 1201 X WTF	EOS4 1351 X WTF	EOS4 1501 X WTF	EOS4 1651 X WTF	EOS4 1801 X WTF
Ordering codes	1110030	1110031	1110032	1110033	1110034	1110035	1110036	1110037	1110038	1110039	1110051	1110052
Resolution 14 mm	EOS4 151 X WTHF	EOS4 301 X WTHF	EOS4 451 X WTHF	EOS4 601 X WTHF	EOS4 751 X WTHF	EOS4 901 X WTHF	EOS4 1051 X WTHF	EOS4 1201 X WTHF	EOS4 1351 X WTHF	EOS4 1501 X WTHF	EOS4 1651 X WTHF	EOS4 1801 X WTHF
Ordering codes	1110040	1110041	1110042	1110043	1110044	1110045	1110046	1110047	1110048	1110049	1110055	1110056
Protected height (mm)	160	310	460	610	760	910	1060	1210	1360	1510	1660	1810

#### Models XH - Max. range: 17 m

 Resolution 30 mm	EOS4 153XH WTF	EOS4 303XH WTF	EOS4 453XH WTF	EOS4 603XH WTF	EOS4 753XH WTF	EOS4 903XH WTF	EOS4 1053XH WTF	EOS4 1203XH WTF	EOS4 1353XH WTF	EOS4 1503XH WTF	EOS4 1653XH WTF	EOS4 1803XH WTF
Ordering codes	1110280	1110281	1110282	1110283	1110284	1110285	1110286	1110287	1110288	1110289	1110053	1110054
Resolution 30 mm	EOS4 153XH WTHF	EOS4 303XH WTHF	EOS4 453XH WTHF	EOS4 603XH WTHF	EOS4 753XH WTHF	EOS4 903XH WTHF	EOS4 1053XH WTHF	EOS4 1203XH WTHF	EOS4 1353XH WTHF	EOS4 1503XH WTHF	EOS4 1653XH WTHF	EOS4 1803XH WTHF
Ordering codes	1110290	1110291	1110292	1110293	1110294	1110295	1110296	1110297	1110298	1110299	1110057	1110058
Protected height (mm)	160	310	460	610	760	910	1060	1210	1360	1510	1660	1810

 2, 3, 4 beams	EOS4 2B XH WTF	EOS4 3B XH WTF	EOS4 4B XH WTF	EOS4 2B XH WTHF	EOS4 3B XH WTHF	EOS4 4B XH WTHF
Ordering codes	1110670	1110671	1110672	1110675	1110676	1110677
Num. beams	2	3	4	2	3	4

Safety Level:

**Compliance according to the corresponding light curtains models**

# EOS4 and EOS2 WTF and WTHF versions

## IP 69K WATERTIGHT ENCLOSURE, WITH OR WITHOUT HEATING SYSTEM

### EOS2 WTF and WTHF MODELS

Models X - Max. range: 10 m

Resolution 30 mm	EOS2	EOS2	EOS2	EOS2	EOS2	EOS2	EOS2	EOS2	EOS2	EOS2	EOS2	EOS2
	153X WTF	303X WTF	453X WTF	603X WTF	753X WTF	903X WTF	1053X WTF	1203X WTF	1353X WTF	1503X WTF	1653X WTF	1803X WTF
Ordering codes	1120230	1120231	1120232	1120233	1120234	1120235	1120236	1120237	1120238	1120239	1120050	1120051
Resolution 30 mm	EOS2	EOS2	EOS2	EOS2	EOS2	EOS2	EOS2	EOS2	EOS2	EOS2	EOS2	EOS2
	153X WTHF	303X WTHF	453X WTHF	603X WTHF	753X WTHF	903X WTHF	1053X WTHF	1203X WTHF	1353X WTHF	1503X WTHF	1653X WTHF	1803X WTHF
Ordering codes	1120240	1120241	1120242	1120244	1120244	1120245	1120246	1120247	1120248	1120249	1120052	1120053
Protected height (mm)	160	310	460	610	760	910	1060	1210	1360	1510	1660	1810

2, 3, 4 beams	EOS2	EOS2	EOS2	EOS2	EOS2	EOS2
	2B X WTF	3B X WTF	4B X WTF	2B X WTHF	3B X WTHF	4B X WTHF
Ordering codes	1120620	1120621	1120622	1120625	1120626	1120627
Num. beams	2	3	4	2	3	4

### DIMENSIONS (mm)

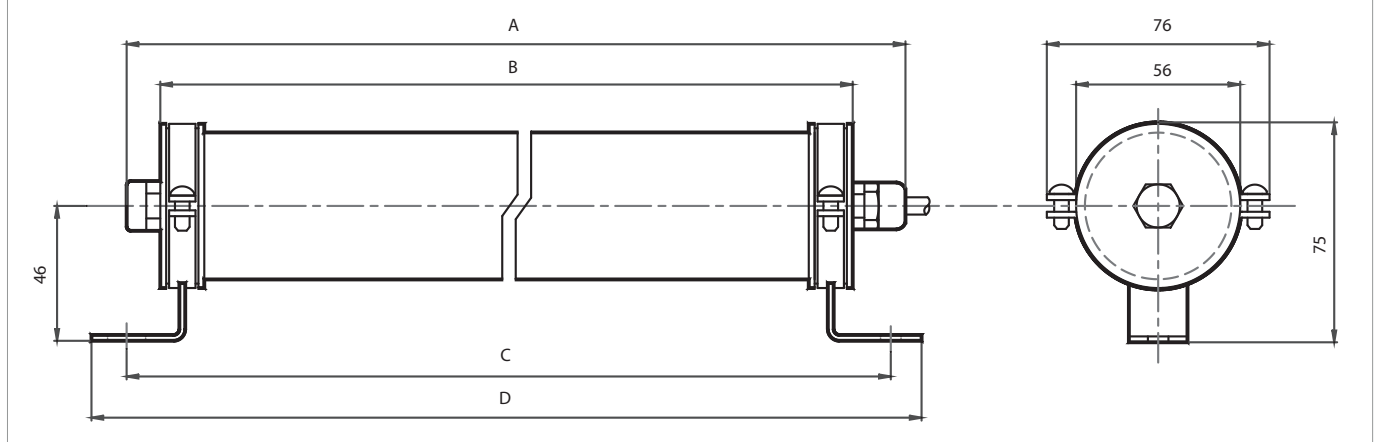

Model	150	300	450	600	750	900	1050	1200	1350	1500	1650	1800	2B	3B	4B
Dimension A mm	320	470	620	770	920	1070	1220	1370	1520	1670	1820	1970	760	1060	1160
Dimension B mm	290	440	620	740	890	1040	1190	1340	1490	1640	1790	1940	730	1030	1130
Dimension C (± 3) mm	315	465	590	765	915	1065	1215	1365	1515	1665	1815	2965	755	1055	1155
Dimension D mm	337	487	637	787	937	1087	1237	1387	1537	1687	1837	2987	777	1077	1177

### ORDERING INFORMATION

Each EOS light curtain comprises:
Emitter and Receiver pair
Mounting brackets
CD-ROM containing the multi-language instruction manual complete with CE declaration of conformity
Quick installation guide

## ADMIRAL AX and VISION VX WT and WTH versions IP 67 WATERTIGHT ENCLOSURE, WITH OR WITHOUT HEATING SYSTEM

### MAIN CHARACTERISTICS

Models for light curtains with 2, 3, 4 beams, 1660 mm and 1810 mm protected height, 30 mm resolution.  
 IP 67 protection rate.  
 Valve to drain humidity and avoid condensation.  
 Tightness to 40 bar water jet pressure.  
 Electrical connections by 10 m pre-wired cable.  
 Polycarbonate transparent housing.  
 PVC sealing caps.

#### Available models:

#### ADMIRAL AX, AX LR; VISION VX, VX LR WT/WTH

- protected height 2, 3, 4 beams
- Max. range 50 m

► **Admiral AX LR technical features can be found at page 76**

► **Vision VX LR technical features can be found at page 138**

#### ADMIRAL AX LR DB WTH

This special version of the Admiral Long Range features an innovative Dual Beam System useful in outdoor applications or in harsh environments for decreasing the sensitivity of the light curtain to small objects that could interrupt the light link, i.e. birds or leaves but also heavy rain or snow.

Available models with 2, 3 beams for detection of the body in access monitoring and heated IP 67 WTH case for outdoor use.

Max. range 60 m.

The safety light curtain/grid is delivered already enclosed into its watertight tube with a 10 m long pre-wired cable and the related fastening brackets.



Safety Level:

**Compliance according to the corresponding light curtains models**

### TECHNICAL FEATURES

Model		WT	WTH
<b>Protection rating</b>		IP 67	
<b>Operating temperature (°C)</b>		0 ... 55	- 25 ... 50
<b>Max. water pressure jets</b>		40 bar - (between 10° and 40° C)	
<b>Max. range (m)</b>	<b>AX, VX</b>	5 or 15 selectable	
<b>Max. range (m)</b>	<b>AX LR, VX LR</b>	20 or 50 selectable	
<b>Max. range (m)</b>	<b>AX LR DB</b>	20 or 60 selectable	
<b>Resolution (mm)</b>	<b>AX, VX</b>	30	
<b>Nr. Beams</b>	<b>AX LR, VX LR, AX LR DB</b>	2, 3, 4	
<b>Protected height (mm)</b>	<b>AX, VX</b>	1660 ... 1810	
<b>Electrical connections</b>		10 metres cable pre-wired with cable gland	
<b>WTH heated power consumption</b>		-	24 VDC - 20 W x Protected Height (m)
<b>Fastening mode</b>		by means set of 4 WFB ring brackets (included)	

# ADMIRAL AX and VISION VX WT and WTH versions IP 67 WATERTIGHT ENCLOSURE, WITH OR WITHOUT HEATING SYSTEM

## ADMIRAL AX WT / WTH MODELS

Max. range.50 m



2, 3, 4 beams	AX 2B LR WT	AX 3B LR WT	AX 4B LR WT	AX 2B LR WTH	AX 3B LR WTH	AX 4B LR WTH
Ordering codes	1134603	1134604	1134605	1139603	1139604	1139605
Num. beams	2	3	4	2	3	4
Overall height (mm)	711	1011	1111	711	1011	1111

Max. range 60 m.



2, 3, 4 beams	AX 2B LR DB WTH	AX 3B LR DB WTH
Ordering codes	1139606	1139607
Num. beams	2	3
Overall height (mm)	772	1072

## VISION VX WT / WTH MODELS

Max. range50 m



2, 3, 4 beams	VX 2B LR WT	VX 3B LR WT	VX 4B LR WT	VX 2B LR WTH	VX 3B LR WTH	VX 4B LR WTh
Ordering codes	1244603	1244604	1244605	1249603	1249604	1249605
Num. beams	2	3	4	2	3	4
Overall height (mm)	711	1011	1111	711	1011	1111

## DIMENSION (mm)

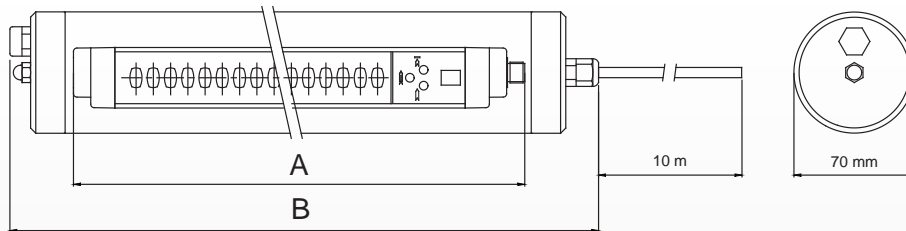

$$B = A (\text{Overall height}) + 130 \text{ mm}$$

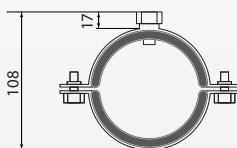

WFB ring brackets (included)

## ORDERING INFORMATION

Each Admiral/Vision light curtain comprises:

Emitter and Receiver pair

Mounting brackets

CD-ROM containing the multi-language instruction manual complete with CE declaration of conformity

Quick installation guide

*Micron*





# Micron

## MAIN FEATURES

Light curtains for industrial and civil applications where it is necessary to detect, measure, and recognise objects.

Depending on the number and position of the beams engaged by an object, Micron can provide real time information to a PLC or PC in order to:

- Detect the presence or absence of objects
- Perform a count
- Detect a position
- Detect a shape or a profile
- Measure dimensions.

**Models MI AV** equipped with two analog outputs (0 ... 10 VDC) with programmable functions and two programmable digital outputs

**Models MI AC** equipped with two analog outputs (4 ... 20 mA) with programmable functions and two programmable digital outputs

**Models MI B** equipped with an RS-485 serial interface with programmable functions and two programmable digital outputs

**Models MI C** equipped with two antivalent solid state outputs.

MicronConfigurator software for PC, with graphic user interface, is supplied with each light curtain (models A and B only). Models A and B are provided with an M5 4-pole connector for parameter configuration and monitoring of the light curtain. It's a USB interface to be connected to a PC using the CSU M5 cable.

Beam spacing available from 5 mm to 75 mm.

Controlled heights

- from 150 mm to 1800 mm - models with beams spacing 5 mm
- from 150 mm to 3000 mm - models with beams spacing 10, 25, 30, 50, 75 mm.

Max. range

- 2 m - models with beams spacing 5 mm
- 6 m - model for automatic warehouses with beams spacing 25, 50, 75 mm ([see page 202](#))
- 12 m - models with beams spacing 30 mm
- 18 m - models with beams spacing 10, 25, 50, 75 mm

Connections with M12 connectors. Up to 100 m of electrical connections with unshielded cables. Possibility of connection of up to 8 Micron B light curtains as nodes of an RS-485 serial line for simultaneous detection of multiple dimensions and complex measurements.

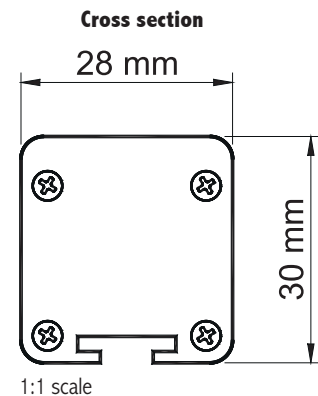

## THE MICRON RANGE

### MICRON A

Two analog outputs (0 ... 10 VDC) model AV or (4 ... 20 mA) model AC with programmable functions + Two programmable digital outputs 0 or 24V.

Solution providing simple measurement with easy interfacing.

Ideal for object measurement and detection of dimensional limits.

Can be provided in WT and WTH version but must be factory programmed.

### MICRON B

RS-485 serial line with programmable functions + two programmable digital outputs 0 or 24V.

Solution providing complete and detailed information on the status of each beam via the RS 485 serial line and, by means of the two solid state outputs, further on/off information related to the occurrence of the programmed conditions.

Ideal for dimensional measurement, detection of object profile and position.

Can be provided in WT and WTH version but must be factory programmed.

### MICRON C

Two digital antivalent outputs 0 or 24V without the need for programming.

Solution providing simple on/off information related to the status of the controlled area.

Ideal for piece counting and detection of object presence/absence in the controlled field.

Can be provided in WT and WTH version.

APPLICATION EXAMPLES

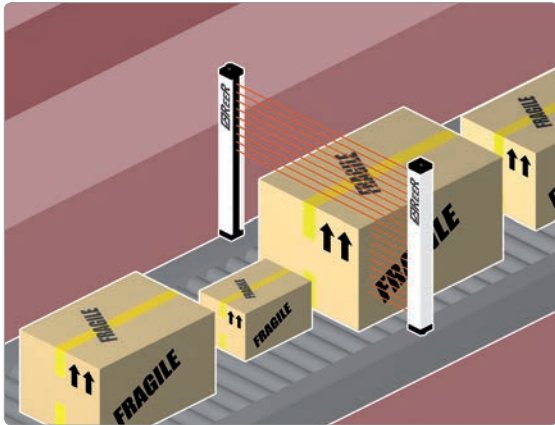

Measurement of the height of objects in transit on conveyor systems

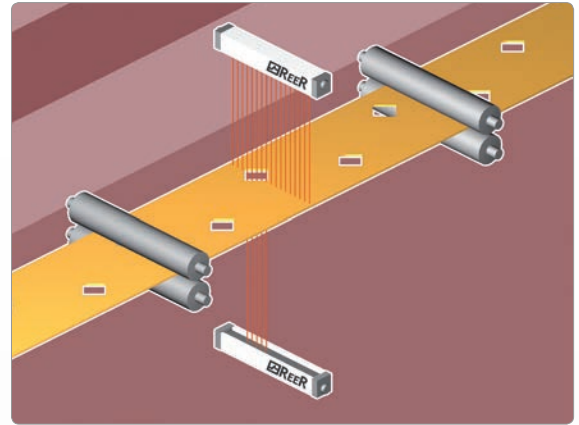

Quality control: verification of presence / absence / position of holes

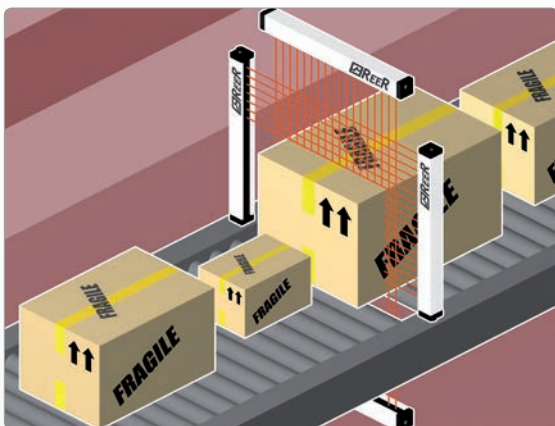

Two-dimensional detection of objects in transit on conveyor systems with use of 2 light curtains. If necessary, the calculation of the volume can be made by means of a third horizontal light curtain, or considering the transit speed

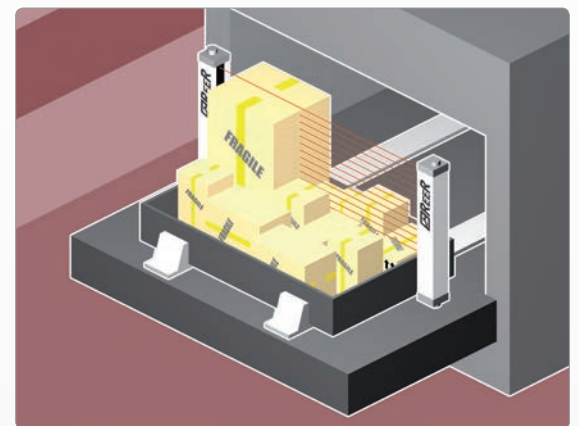

Automatic warehouses: detection of maximum height of the objects present in the boxes for efficient management of the machine's capacity

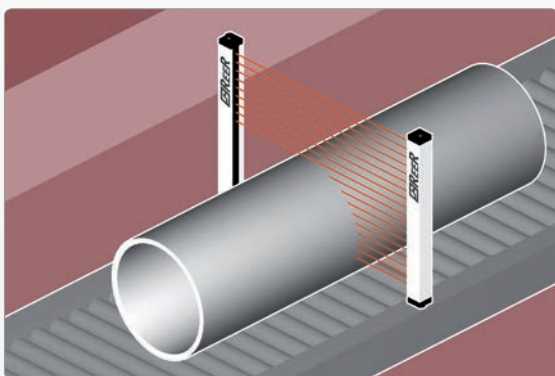

Measurement and identification of cylinders of various sizes

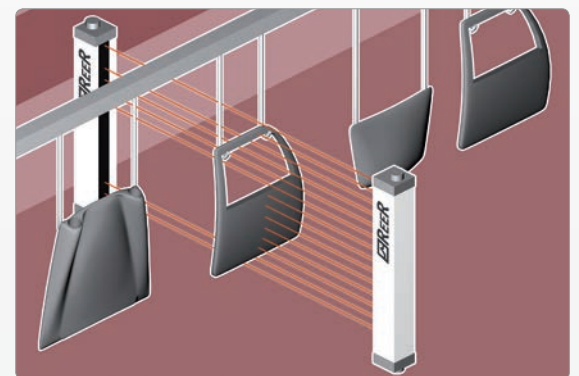

Detection of position and profile of pieces in automatic painting systems

## APPLICATION EXAMPLES

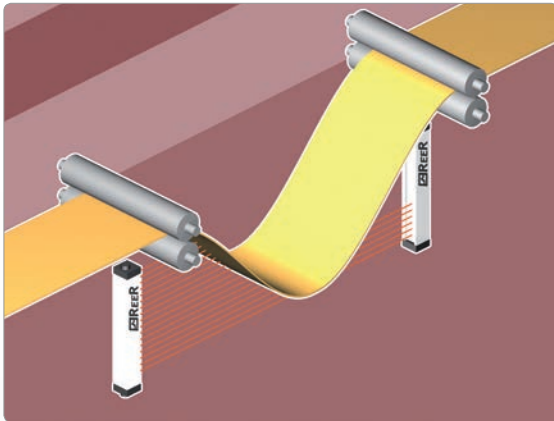

**Loop control**

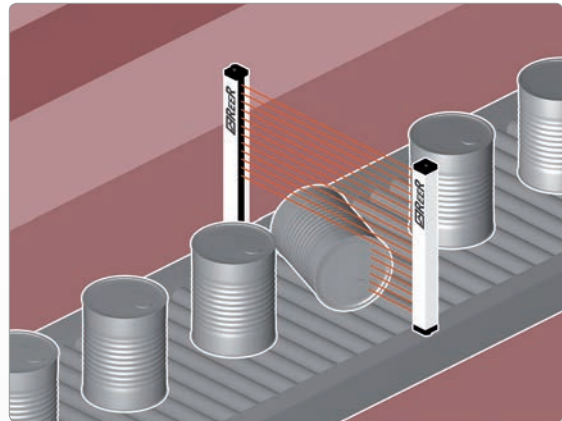

**Quality control: verification of correct positioning of objects**

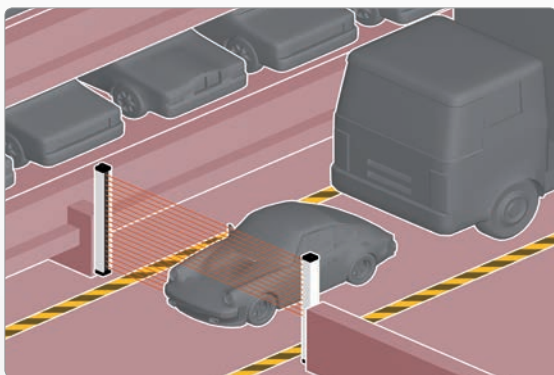

**Detection of overall dimensional limits of vehicles for vehicle handling in automatic parking garages**

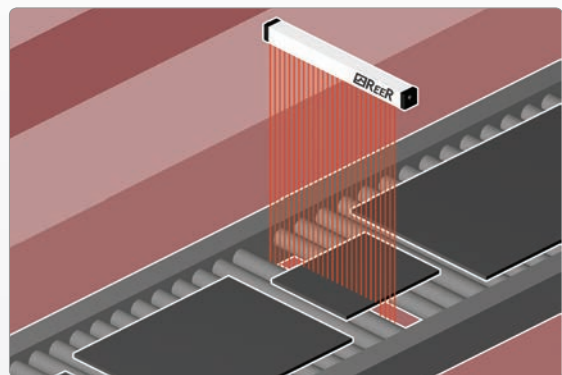

**Measurement of the width and position of panels or sheets of material in transit on roller units or conveyor belts**

## Special models

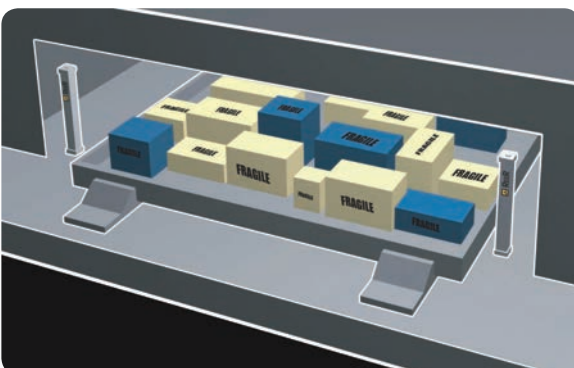

**Automatic warehouses: detection of maximum height of the objects present in the boxes for efficient management of the machine's capacity**

### Special models with beams spacing: 25, 50, 75 mm

The special optics of these light curtains allow detection of small objects in quick motion.

Please contact Reer for availability and models.

**TECHNICAL FEATURES**

<b>Controlled heights (mm)</b>		150 ... 1800 – models with beams spacing 5 mm 150 ... 3000 mm - models with beams spacing 10, 25, 30, 50, 75 mm.
<b>Beam spacing (mm)</b>		5, 10, 25, 30, 50, 75
<b>Max. range (m)</b>		2 - models with beam spacing 5 mm 6 - models model for automatic warehouses with beams spacing 25, 50, 75 mm 12 - models with beam spacing 30 mm 18 - models with beam spacing 10, 25, 50, 75 mm
<b>Measurement time</b>		(500 μs + 70 μs x n beams) x N Where N = scan cycles (1,2,3 selectable)
<b>Scan cycles</b>		1, 2, 3 selectable
<b>Inputs (on receiver) (Micron A and B only)</b>		1 - digital with programmable functions - 0 or 24V
<b>Outputs</b>	<b>Micron MI AV Micron MI AC</b>	2 analog outputs (0-10 VDC) with programmable functions + 2 programmable digital outputs 0 or 24V 2 analog outputs (4-20 mA) with programmable functions + 2 programmable digital outputs 0 or 24V
	<b>Micron MI B</b>	RS-485 Serial line (up to 8 nodes) 2 - solid state 0 or 24V programmable - PNP 100 mA at 24 VDC
	<b>Micron MI C</b>	2 - solid state 0 or 24V antivalent - PNP 100 mA at 24 VDC
<b>Micron A and B programming</b>		via "MicronConfigurator" configuration software
<b>Micron A and B programming interface</b>		USB interface on M5 connector
<b>Synchronisation between emitter and receiver</b>		Optical or via cable, selectable
<b>Electrical connections</b>	<b>Micron A and B</b>	connector M12 5-pole (emitter) connector M12 8-pole (receiver) M5 4-pole connector for programming interface
	<b>Micron C</b>	2 M12 5-pole connectors (emitter and receiver)
<b>Signalling</b>		LEDs for operating status and light curtain self-diagnosis
<b>Power supply (VDC)</b>		24 ± 20%
<b>Max. length connection cables between light curtain and interface (m)</b>		100
<b>Operating temperature (°C)</b>		-10 ... + 55
<b>Protection rating</b>		IP 65 and IP 67
<b>Fastening mode</b>		back slot, or to the top and lower end with SFB E180 rotating brackets (optional)
<b>Cross-section dimensions (mm)</b>		28 x 30

**Connectors**

**Micron AV, AC  
Micron B  
Micron C**

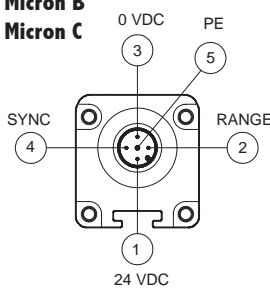

Emitter M12 5-pole

**Micron B**

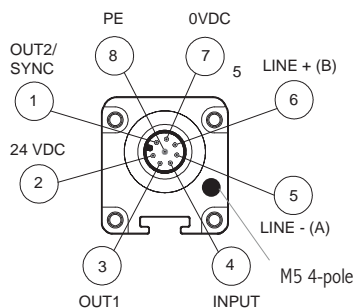

Receiver M12 8-pole

**Micron AV, AC**

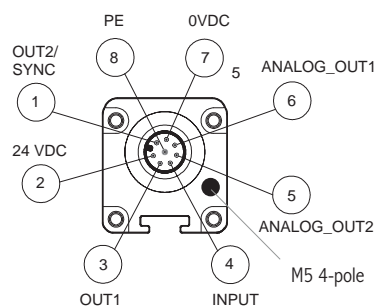

Receiver M12 8-pole

**Micron C**

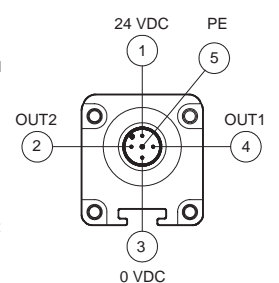

Receiver M12 5-pole

# Micron

Models Max. range: 2 m

Spring 2015

Beam spacing 5 mm	MI 150AV	MI 300AV	MI 450AV	MI 600AV	MI 750AV	MI 900AV	MI 1050AV	MI 1200AV	MI 1350AV	MI 1500AV	MI 1650AV	MI 1800AV
Ordering codes	1250500	1250501	1250502	1250503	1250504	1250505	1250506	1250507	1250508	1250509	1250510	1250511
Beam spacing 5 mm	MI 150AC	MI 300AC	MI 450AC	MI 600AC	MI 750AC	MI 900AC	MI 900AC	MI 1200AC	MI 1350AC	MI 1500AC	MI 1650AC	MI 1800AC
Ordering codes	1250520	1250521	1250522	1250523	1250524	1250525	1250526	1250527	1250528	1250529	1250530	1250531
Beam spacing 5 mm	MI 150B	MI 300B	MI 450B	MI 600B	MI 750B	MI 900B	MI 1050B	MI 1200B	MI 1350B	MI 1500B	MI 1650B	MI 1800B
Ordering codes	1250540	1250541	1250542	1250543	1250544	1250545	1250546	1250547	1250548	1250549	1250550	1250551
Beam spacing 5 mm	MI 150C	MI 300C	MI 450B	MI 600B	MI 750B	MI 900B	MI 1050B	MI 1200B	MI 1350C	MI 1500C	MI 1650C	MI 1800C
Ordering codes	1250560	1250561	1250562	1250563	1250564	1250565	1250566	1250567	1250568	1250569	1250570	1250571
Controlled height (mm)	145	295	445	595	745	895	1045	1195	1345	1495	1645	1795
Number of beams	30	60	90	120	150	180	210	240	270	300	330	360
Overall height (mm)	213	363	513	663	813	963	1113	1263	1413	1563	1713	1863

Models Max. range: 18 m

Summer 2014

Beam spacing 10 mm	MI 151AV	MI 301AV	MI 451AV	MI 601AV	MI 751AV	MI 901AV	MI 1051AV	MI 1201AV	MI 1351AV	MI 1501AV	MI 1651AV	MI 1801AV
Ordering codes	1250020	1250021	1250022	1250023	1250024	1250025	1250026	1250027	1250028	1250029	1250030	1250031
Beam spacing 10 mm	MI 151AC	MI 301AC	MI 451AC	MI 601AC	MI 751AC	MI 901AC	MI 1051AC	MI 1201AC	MI 1351AC	MI 1501AC	MI 1651AC	MI 1801AC
Ordering codes	1250120	1250121	1250122	1250123	1250124	1250125	1250126	1250127	1250128	1250129	1250130	1250131
Beam spacing 10 mm	MI 151B	MI 301B	MI 451B	MI 601B	MI 751B	MI 901B	MI 1051B	MI 1201B	MI 1351B	MI 1501B	MI 1651B	MI 1801B
Ordering codes	1250220	1250221	1250222	1250223	1250224	1250225	1250226	1250227	1250228	1250229	1250230	1250231
Beam spacing 10 mm	MI 151C	MI 301C	MI 451C	MI 601C	MI 751C	MI 901C	MI 1051C	MI 1201C	MI 1351C	MI 1501C	MI 1651C	MI 1801C
Ordering codes	1250320	1250321	1250322	1250323	1250324	1250325	1250326	1250327	1250328	1250329	1250330	1250331
Controlled height (mm)	140	290	440	590	740	890	1040	1190	1340	1490	1640	1790
Number of beams	15	30	45	60	75	90	105	120	135	150	165	180
Overall height (mm)	213	363	513	763	813	963	1113	1263	1413	1563	1713	1863

Beam spacing 10 mm	MI 1951AV	MI 2101AV	MI 2251AV	MI 2401AV	MI 2551AV	MI 2701AV	MI 2851AV	MI 3001AV
Ordering codes	1250032	1250033	1250034	1250035	1250036	1250037	1250038	1250039
Beam spacing 10 mm	MI 1951AC	MI 2101AC	MI 2251AC	MI 2401AC	MI 2551AC	MI 2701AC	MI 2851AC	MI 3001AC
Ordering codes	1250132	1250133	1250134	1250135	1250136	1250137	1250138	1250139
Beam spacing 10 mm	MI 1951B	MI 2101B	MI 2251B	MI 2401B	MI 2551B	MI 2701B	MI 2851B	MI 3001B
Ordering codes	1250232	1250233	1250234	1250235	1250236	1250237	1250238	1250239
Beam spacing 10 mm	ME 1951C	ME 2101C	ME 2251C	ME 2401C	MI 2551C	MI 2701C	MI 2851C	MI 3001C
Ordering codes	1250332	1250333	1250334	1250335	1250336	1250337	1250338	1250339
Controlled height (mm)	1940	2090	2240	2390	2540	2690	2840	2990
Number of beams	195	210	225	240	255	270	285	300
Overall height (mm)	2013	2163	2313	2463	2613	2763	2913	3063



**Models Max. range: 18 m**

**Available**

<b>Beam spacing 25 mm</b>	MI 152AV	MI 302AV	MI 452AV	MI 602AV	MI 752AV	MI 902AV	MI 1052AV	MI 1202AV	MI 1352AV	MI 1502AV	MI 1652AV	MI 1802AV
Ordering codes	1250040	1250041	1250042	1250043	1250044	1250045	1250046	1250047	1250048	1250049	1250050	1250051
<b>Beam spacing 25 mm</b>	MI 152AC	MI 302AC	MI 452AC	MI 602AC	MI 752AC	MI 902AC	MI 1052AC	MI 1202AC	MI 1352AC	MI 1502AC	MI 1652AC	MI 1802AC
Ordering codes	1250140	1250141	1250142	1250143	1250144	1250145	1250146	1250147	1250148	1250149	1250150	1250151
<b>Beam spacing 25 mm</b>	MI 152B	MI 302B	MI 452B	MI 602B	MI 752B	MI 902B	MI 1052B	MI 1202B	MI 1352B	MI 1502B	MI 1652B	MI 1802B
Ordering codes	1250240	1250241	1250242	1250243	1250244	1250245	1250246	1250247	1250248	1250249	1250250	1250251
<b>Beam spacing 25 mm</b>	MI 152C	MI 302C	MI 452C	MI 602C	MI 752C	MI 902C	MI 1052C	MI 1202C	MI 1352C	MI 1502C	MI 1652C	MI 1802C
Ordering codes	1250340	1250341	1250342	1250343	1250344	1250345	1250346	1250347	1250348	1250349	1250350	1250351
Controlled height (mm)	125	275	425	575	725	875	1025	1175	1325	1475	1625	1775
Number of beams	6	12	18	24	30	36	42	48	54	60	66	72
Overall height (mm)	213	363	513	663	813	963	1113	1263	1413	1563	1713	1863
<b>Beam spacing 25 mm</b>	MI 1952AV	MI 2102AV	MI 2252AV	MI 2402AV	MI 2552AV	MI 2702AV	MI 2852AV	MI 3002AV				
Ordering codes	1250052	1250053	1250054	12500455	1250056	1250057	1250058	1250059				
<b>Beam spacing 25 mm</b>	MI 1952AC	MI 2102AC	MI 2252AC	MI 2402AC	MI 2552AC	MI 2702AC	MI 2852AC	MI 3002AC				
Ordering codes	1250152	1250153	1250154	1250155	1250156	1250157	1250158	1250159				
<b>Beam spacing 25 mm</b>	MI 1952B	MI 2102B	MI 2252B	MI 2402B	MI 2552B	MI 2702B	MI 2852B	MI 3002B				
Ordering codes	1250252	1250253	1250254	1250255	1250256	1250257	1250258	1250259				
<b>Beam spacing 25 mm</b>	MI 1952C	MI 2102C	MI 2252C	MI 2402C	MI 2552C	MI 2702C	MI 2852C	MI 3002C				
Ordering codes	1250352	1250353	1250354	1250355	1250356	1250357	1250358	1250359				
Controlled height (mm)	1925	2075	2225	2375	2525	2625	2825	2975				
Number of beams	78	84	90	96	102	108	114	120				
Overall height (mm)	2013	2163	2313	2463	2613	2763	2913	3063				

**Models Max. range: 12 m**

**Summer 2014**

<b>Beam spacing 30 mm</b>	MI 153AV	MI 303AV	MI 453AV	MI 603AV	MI 753AV	MI 903AV	MI 1053AV	MI 1203AV	MI 1353AV	MI 1503AV	MI 1653AV	MI 1803AV
Ordering codes	1250060	1250061	1250062	1250063	1250064	1250065	1250066	1250067	1250068	1250069	1250070	1250071
<b>Beam spacing 30 mm</b>	MI 153AC	MI 303AC	MI 453AC	MI 603AC	MI 753AC	MI 903AC	MI 1053AC	MI 1203AC	MI 1353AC	MI 1503AC	MI 1653AC	MI 1803AC
Ordering codes	1250160	1250161	1250162	1250163	1250164	1250165	1250166	1250167	1250168	1250169	1250170	1250171
<b>Beam spacing 30 mm</b>	MI 153B	MI 303B	MI 453B	MI 603B	MI 753B	MI 903B	MI 1053B	MI 1203B	MI 1353B	MI 1503B	MI 1653B	MI 1803B
Ordering codes	1250260	1250261	1250262	1250263	1250264	1250265	1250266	1250267	1250268	1250269	1250270	1250271
<b>Beam spacing 30 mm</b>	MI 153C	MI 303C	MI 453C	MI 603C	MI 753C	MI 903C	MI 1053C	MI 1203C	MI 1353C	MI 1503C	MI 1653C	MI 1803C
Ordering codes	1250360	1250361	1250362	1250363	1250364	1250365	1250366	1250367	1250368	1250369	1250370	1250371
Controlled height (mm)	120	270	420	570	720	870	1020	1170	1320	1470	1620	1770
Number of beams	5	10	15	20	25	30	35	40	45	50	55	60
Overall height (mm)	213	363	513	663	813	963	1113	1263	1413	1563	1713	1863

# Micron

Beam spacing 30 mm	MI 1953AV	MI 2103AV	MI 2253AV	MI 2403AV	MI 2553AV	MI 2703AV	MI 2853AV	MI 3003AV
Ordering codes	1250072	1250073	1250074	1250075	1250076	1250077	1250078	1250079
Beam spacing 30mm	MI 1953AC	MI 2103AC	MI 2253AC	MI 2403AC	MI 2553AC	MI 2703AC	MI 2853AC	MI 3003AC
Ordering codes	1250172	1250173	1250174	1250175	1250176	1250177	1250178	1250179
Beam spacing 30 mm	MI 1953B	MI 2103B	MI 2253B	MI 2403B	MI 2553B	MI 2703B	MI 2853B	MI 3003B
Ordering codes	1250272	1250273	1250274	1250275	1250276	1250277	1250278	1250279
Beam spacing 30 mm	MI 1953C	MI 2103C	MI 2253C	MI 2403C	MI 2553C	MI 2703C	MI 2853C	MI 3003C
Ordering codes	1250372	1250373	1250374	1250375	1250376	1250377	1250378	1250379
Controlled height (mm)	1920	2070	2220	2370	2520	2620	2820	2970
Number of beams	65	70	75	80	85	90	95	100
Overall height (mm)	2013	2163	2313	2463	2613	2763	2913	3063

Models Max. range: 18 m

Available

Beam spacing 50 mm	MI 155AV	MI 305AV	MI 455AV	MI 605AV	MI 755AV	MI 905AV	MI 1055AV	MI 1205AV	MI 1355AV	MI 1505AV	MI 1655AV	MI 1805AV
Ordering codes	1250080	1250081	1250082	1250083	1250084	1250085	1250086	1250087	1250088	1250089	1250090	1250091
Beam spacing 50 mm	MI 155AC	MI 305AC	MI 455AC	MI 605AC	MI 755AC	MI 905AC	MI 1055AC	MI 1205AC	MI 1355AC	MI 1505AC	MI 1655AC	MI 1805AC
Ordering codes	1250180	1250181	1250182	1250183	1250184	1250185	1250186	1250187	1250188	1250189	1250190	1250191
Beam spacing 50 mm	MI 155B	MI 305B	MI 455B	MI 605B	MI 755B	MI 905B	MI 1055B	MI 1205B	MI 1355B	MI 1505B	MI 1655B	MI 1805B
Ordering codes	1250280	1250281	1250282	1250283	1250284	1250285	1250286	1250287	1250288	1250289	1250290	1250291
Beam spacing 50 mm	MI 155C	MI 305C	MI 455C	MI 605C	MI 755C	MI 905C	MI 1055C	MI 1205C	MI 1355C	MI 1505C	MI 1655C	MI 1805C
Ordering codes	1250380	1250381	1250382	1250383	1250384	1250385	1250386	1250387	1250388	1250389	1250390	1250391
Controlled height (mm)	100	250	400	550	700	850	1000	1150	1300	1450	1600	1750
Number of beams	3	6	9	12	15	18	21	24	27	30	33	36
Overall height (mm)	213	363	513	663	813	963	1113	1263	1413	1563	1713	1863

Beam spacing 50 mm	MI 1955AV	MI 2105AV	MI 2255AV	MI 2405AV	MI 2555AV	MI 2705AV	MI 2855AV	MI 3005AV
Ordering codes	1250092	1250093	1250094	1250095	1250096	1250097	1250098	1250099
Beam spacing 50mm	MI 1955AC	MI 2105AC	MI 2255AC	MI 2405AC	MI 2555AC	MI 2705AC	MI 2855AC	MI 3005AC
Ordering codes	1250192	1250193	1250194	1250195	1250196	1250197	1250198	1250199
Beam spacing 50 mm	MI 1955B	MI 2105B	MI 2255B	MI 2405B	MI 2555B	MI 2705B	MI 2855B	MI 3005B
Ordering codes	1250292	1250293	1250294	1250295	1250296	1250297	1250298	1250299
Beam spacing 50 mm	MI 1955C	MI 2105C	MI 2255C	MI 2405C	MI 2555C	MI 2705C	MI 2855C	MI 3005C
Ordering codes	1250392	1250393	1250394	1250395	1250396	1250397	1250398	1250399
Controlled height (mm)	1900	2050	2200	2350	2500	2650	2800	2950
Number of beams	39	42	45	48	51	54	57	60
Overall height (mm)	2013	2163	2313	2463	2613	2763	2913	3063



Models Max. range: 18 m

Available

<b>Beam spacing 75 mm</b>	MI 157AV	MI 307AV	MI 457AV	MI 607AV	MI 757AV	MI 907AV	MI 1057AV	MI 1207AV	MI 1357AV	MI 1507AV	MI 1657AV	MI 1807AV
Ordering codes	1250100	1250101	1250102	1250103	1250104	1250105	1250106	1250107	1250108	1250109	1250110	1250111
<b>Beam spacing 75 mm</b>	MI 157AC	MI 307AC	MI 457AC	MI 607AC	MI 757AC	MI 907AC	MI 1057AC	MI 1207AC	MI 1357AC	MI 1507AC	MI 1657AC	MI 1807AC
Ordering codes	1250200	1250201	1250202	1250203	1250204	1250205	1250206	1250207	1250208	1250209	1250210	1250211
<b>Beam spacing 75 mm</b>	MI 157B	MI 307B	MI 457B	MI 607B	MI 757B	MI 907B	MI 1057B	MI 1207B	MI 1357B	MI 1507B	MI 1657B	MI 1807B
Ordering codes	1250300	1250301	1250302	1250303	1250304	1250305	1250306	1250307	1250308	1250309	1250310	1250311
<b>Beam spacing 75 mm</b>	MI 157C	MI 307C	MI 457C	MI 607C	MI 757C	MI 907C	MI 1057C	MI 1207C	MI 1357C	MI 1507C	MI 1657C	MI 1807C
Ordering codes	1250400	1250401	1250402	1250403	1250404	1250405	1250406	1250407	1250408	1250409	1250410	1250411
Controlled height (mm)	75	225	375	525	675	825	975	1125	1275	1425	1575	1725
Number of beams	2	4	6	8	10	12	14	16	18	20	22	24
Overall height (mm)	213	363	513	663	813	963	1113	1263	1413	1563	1713	1863
<b>Beam spacing 75 mm</b>	MI 1957AV	MI 2107AV	MI 2257AV	MI 2407AV	MI 2557AV	MI 2707AV	MI 2857AV	MI 3007AV				
Ordering codes	1250112	1250113	1250114	1250115	1250116	1250117	1250118	1250119				
<b>Beam spacing 75mm</b>	MI 1957AC	MI 2107AC	MI 2257AC	MI 2407AC	MI 2557AC	MI 2707AC	MI 2857AC	MI 3007AC				
Ordering codes	1250212	1250213	1250214	1250215	1250216	1250217	1250218	1250219				
<b>Beam spacing 75 mm</b>	MI 1957B	MI 2107B	MI 2257B	MI 2407B	MI 2557B	MI 2707B	MI 2857B	MI 3007B				
Ordering codes	1250312	1250313	1250314	1250315	1250316	1250317	1250318	1250319				
<b>Beam spacing 75 mm</b>	MI 1957C	MI 2107C	MI 2257C	MI 2407C	MI 2557C	MI 2707C	MI 2857C	MI 3007C				
Ordering codes	1250412	1250413	1250414	1250415	1250416	1250417	1250418	1250419				
Controlled height (mm)	1875	2025	2175	2325	2475	2625	2775	2925				
Number of beams	26	28	30	32	34	36	38	40				
Overall height (mm)	2013	2163	2313	2463	2613	2763	2913	3063				

► "ACCESSORIES" on page 209

## ORDERING INFORMATION

In addition to the height and beam spacing, to uniquely define a Micron light curtain the model must also be indicated AV, AC, B or C:

**Model AV (0 ... 10 Vcc)** 2 analog outputs (0-10 VDC) with programmable functions + 2 programmable digital outputs 0 or 24V  
**Model AC (4 ... 20 mA)** 2 analog outputs (4-20 mA) with programmable functions + 2 programmable digital outputs 0 or 24V.

**Model B** RS-485 Serial line (up to 8 nodes) + 2 - solid state 0 or 24V programmable

**Model C** 2 - solid state 0/24V antivalent. Without the need for programming.

**Each type of Micron light curtain includes:**

- Emitter and Receiver pair
- Mounting brackets and T-nuts
- CD-ROM containing the "MicronConfigurator" programming software and the multi-language instruction manual

**USB cable (CSU M5)** To connect light curtains and PC for system configuration. Models A and B only . This cable must be ordered separately. See accessories table.



## DIMENSIONS (mm)

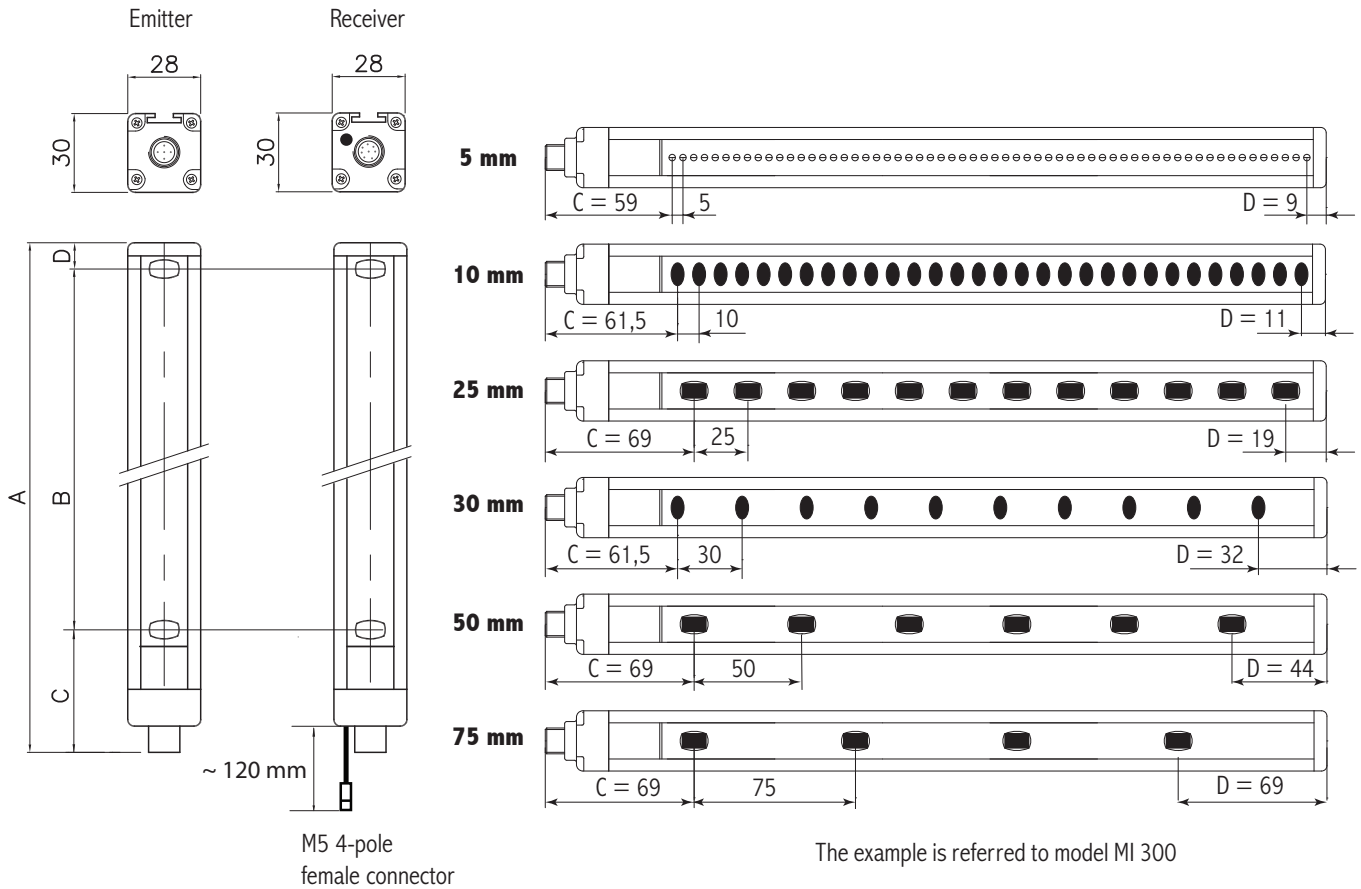

Model MI	150	300	450	600	750	900	1050	1200	1350
<b>A</b>	213	363	513	663	813	963	1113	1263	1413
<b>B (measuring height)</b>	B = (number of beams -1) x beam spacing								
<b>C (1<sup>st</sup> beam position)</b>	59 (for 5 mm model) - 61,5 (for 10 and 30 mm models) - 69 (for 25, 50 and 75 mm models)								
<b>Mounting</b>	Complete set of 4 LE type brackets included in the package						Complete set of 6 LE type brackets included in the package		

Model MI	1500	1650	1800	1950	2100	2250	2400	2550	2700	2850	3000
<b>A</b>	1563	1713	1863	2013	2163	2313	2463	2613	2763	2913	3063
<b>B (controlled height)</b>	B = (number of beams -1) x beam spacing										
<b>C (1<sup>st</sup> beam position)</b>	59 (for 5 mm model) - 61,5 (for 10 and 30 mm models) - 69 (for 25, 50 and 75 mm models)										
<b>Mounting</b>	Complete set of 6 LE type brackets included in the package										



### WARNING

When the light curtain works in the presence of strong vibrations (presses, weaving machines etc.), in order to avoid damages to the light curtain it is necessary to use the vibration dampers SAV (available as accessories)

**ACCESSORIES**

For Micron light curtains the following accessories, to be ordered separately, are available:

FMC floor mounting columns	▶ See page 220
SP deflection mirrors	▶ See page. 223
LAD laser alignment device	▶ See page 224
SAV vibrations dampers	▶ See page 225
SFB swivel fixing brackets	▶ See page 226
Connectors	▶ See list hereunder:

**CONNECTORS Micron C emitter and receiver / Micron A and B only emitter**

Model	Code	Description
CD 5	1330950	M12 straight connector, 5 poles, pre-wired cable 5 m
CD 10	1330956	M12 straight connector, 5 poles, pre-wired cable 10 m
CD 15	1330952	M12 straight connector, 5 poles, pre-wired cable 15 m
CD 20	1330957	M12 straight connector, 5 poles, pre-wired cable 20 m
CD 25	1330949	M12 straight connector, 5 poles, pre-wired cable 25 m
CD 50	1330965	M12 straight connector, 5 poles, pre-wired cable 50 m
CD 95	1330951	M12 90° angle connector, 5 poles, pre-wired cable 5 m
CD 910	1330958	M12 90° angle connector, 5 poles, pre-wired cable 10 m
CD 915	1330953	M12 90° angle connector, 5 poles, pre-wired cable 15 m
CDM 9	1330954	M12 straight connector, 5 poles with screw terminal, PG9 cable gland
CDM 99	1330955	M12 90° angle connector, 5 poles with screw terminal, PG9 cable gland

**CONNETTORI MICRON A and B receiver**

Model	Code	Description
CSU M5	1250900	2 meters cable for connecting light curtain and PC for system configuration, equipped with M5 4-pole connector and one USB A connector
C8D 5	1330980	M12 straight connector, 8 poles, pre-wired cable 5 m
C8D 10	1330981	M12 straight connector, 8 poles, pre-wired cable 10 m
C8D 15	1330982	M12 straight connector, 8 poles, pre-wired cable 15 m
C8D 25	1330967	M12 straight connector, 8 poles, pre-wired cable 25 m
C8D 40	1440966	M12 straight connector, 8 poles, pre-wired cable 40 m
C8D 95	1330983	M12 90° angle connector, 8 poles, pre-wired cable 5 m
C8D 910	1330984	M12 90° angle connector, 8 poles, pre-wired cable 10 m
C8D 915	1330985	M12 90° angle connector, 8 poles, pre-wired cable 15 m
C8DM 9	1330986	M12 straight connector, 8 poles with screw terminal, PG9 cable gland
C8DM 99	1330987	M12 90° angle connector, 8 poles with screw terminal, PG9 cable gland
C8DM 11	1330978	M12 straight connector, 8 poles with screw terminal, PG9/11 cable gland
C8DM 911	1330979	M12 90° angle connector, 8 poles with screw terminal, PG9/11 cable gland

**CHARACTERISTICS OF "MicronConfigurator" CONFIGURATOR SOFTWARE**

<b>Possibility for on-line display on PC screen during operation</b>	Status of each individual beam and solid state outputs
<b>Configurable parameters</b>	Operating logic (conditions for output activation), parameters of the RS-485 serial line (transmission method, baud rate, parity, start-stop characters, binary, hex, ascii format, measurement time, etc.)



# METRON



# METRON

## MAIN FEATURES

Light curtains for industrial and civil applications where it is necessary to detect, measure, and recognise objects.

Depending on the number and position of the beams engaged by an object, METRON can provide real time information to a PLC or PC in order to:

- • Detect the presence or absence of objects
- • Perform a count
- • Detect a position
- • Detect a shape or a profile
- • Measure dimensions

**Models A** equipped with 4 programmable solid state outputs.

**Models B** equipped with 2 programmable solid state outputs and an RS-485 serial interface.

**Models C** equipped with two antivalent solid state outputs.

The Metronconf Configuration software for PC, with graphic user interface, is supplied with each light curtain (models A and B only).

Beam spacing available from 5 mm to 75 mm.

Controlled height from 140 mm to 2525 mm.

Max. range 16 m (10 mm and 30 mm models).

Connections with M12 and M16 connectors. Up to 50 m of electrical connections with unshielded cables.

Possibility of connection of up to 8 Metron B light curtains as nodes of an RS-485 serial line for simultaneous detection of multiple dimensions and complex measurements.

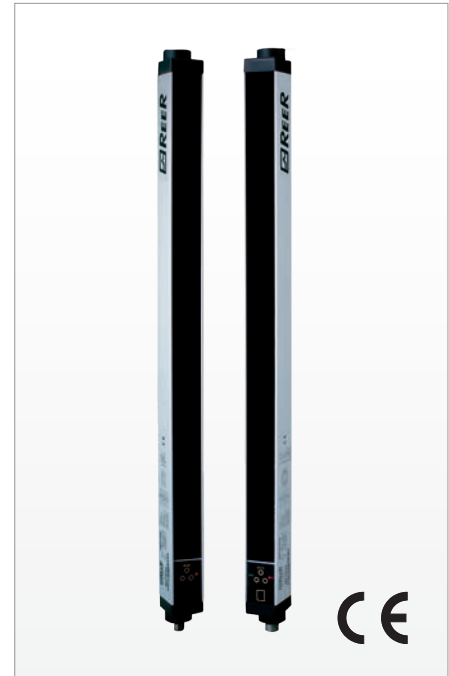

### Cross section

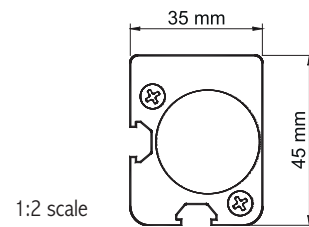

## THE METRON RANGE

### METRON A

#### 4 solid state outputs 0 or 24V with programmable functions

Solution providing simple on/off information related to the occurrence of the programmed conditions

*Ideal for object recognition, quality control, detection of dimensional limits*

### METRON B

#### RS-485 serial line + two solid state outputs 0 or 24V with programmable functions

Solution providing complete and detailed information on the status of each beam via the RS-485 serial line and, by means of the two solid state outputs, further on/off information related to the occurrence of the programmed conditions

*Ideal for dimensional measurement, detection of object profile and position*

### METRON C

#### Two solid state antivalent outputs 0 or 24V without the need for programming

Solution providing simple on/off information related to the status of the controlled area

*Ideal for piece counting and detection of object presence/absence in the controlled field*

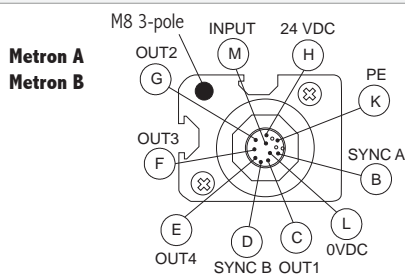
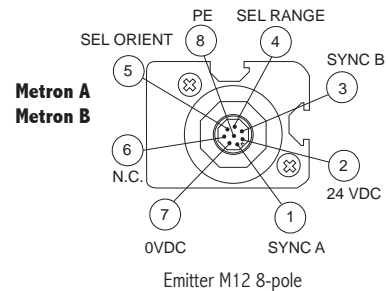

Receiver M16 12-pole

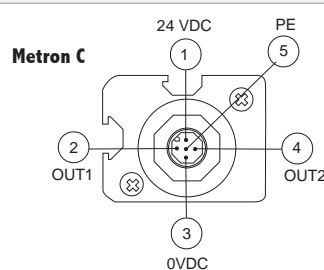

Receiver M12 5-pole

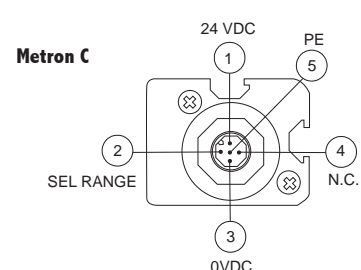

Emitter M12 5-pole

**APPLICATION EXAMPLES**

See Micron previous section for the application sample.

► See page 201

**TECHNICAL FEATURES**

<b>Controlled heights (mm)</b>		140 ... 2525
<b>Beam spacing (mm)</b>		5, 10, 25, 30, 50, 75
<b>Max. range (m)</b>		2 – for models with beam spacing 5 mm 6 - for models with beam spacing 25, 50, 75 mm 16 - for models with beam spacing 10, 30 mm
<b>Measurement time</b>		(2.25 ms + 70 µs x n beams) x 2
<b>Outputs</b>	<b>Metron A</b>	4 - solid state 0 or 24V programmable - PNP 100 mA at 24 VDC
	<b>Metron B</b>	RS-485 Serial line (up to 8 nodes) 2 - solid state 0 or 24V programmable - PNP 100 mA at 24 VDC
	<b>Metron C</b>	2 - solid state 0 or 24V antivalent - PNP 100 mA at 24 VDC
<b>Inputs (on receiver) (Metron A and B only)</b>		1 - digital with programmable functions - 0 or 24V
<b>Metron A and B programming</b>		via Metronconf configuration software
<b>Metron A and B programming interface</b>		RS-232 serial line
<b>Synchronisation between emitter and receiver</b>		Optical or via cable, selectable
<b>Electrical connections</b>	<b>Metron A and B</b>	1 connector M12 8-pole (emitter) 1 main connector M16 12-pole (receiver) 1 secondary connector M8 3-pole for RS-232 line for programming (receiver)
	<b>Metron C</b>	M12 5-pole connectors (emitter and receiver)
<b>Signalling</b>		7-segment display and LEDs for operating status and light curtain self-diagnosis
<b>Power supply (VDC)</b>		24 ± 20%
<b>Max. length connection cables between light curtain and interface (m)</b>		50
<b>Operating temperature (°C)</b>		0 ... 55
<b>Protection rating</b>		IP 65
<b>Fastening mode</b>		3: back slot, side slot, or to the top and lower end with swivel brackets
<b>Cross-section dimensions (mm)</b>		35 x 45

**CHARACTERISTICS OF METRONCONF CONFIGURATION SOFTWARE**

<b>Possibility for on-line display on PC screen during operation (via RS-232)</b>	Status of each individual beam and solid state outputs
<b>Configurable parameters</b>	Operating logic (conditions for output activation), parameters of the RS-485 serial line (transmission method, baud rate, parity, start-stop characters, binary, hex, ascii format, etc.)

# METRON

## MODELS

Beam spacing 5 mm	ME 150A	ME 300A	ME 450A	ME 600A	ME 750A	ME 900A	ME 1050A	ME 1200A
Ordering codes	<b>1380500</b>	<b>1380501</b>	<b>1380502</b>	<b>1380503</b>	<b>1380504</b>	<b>1380505</b>	<b>1380506</b>	<b>1380507</b>
Beam spacing 5 mm	ME 150B	ME 300B	ME 450B	ME 600B	ME 750B	ME 900B	ME 1050B	ME 1200B
Ordering codes	<b>1380520</b>	<b>1380521</b>	<b>1380522</b>	<b>1380523</b>	<b>1380524</b>	<b>1380525</b>	<b>1380526</b>	<b>1380527</b>
Beam spacing 5 mm	ME 150C	ME 300C	ME 450B	ME 600B	ME 750B	ME 900B	ME 1050B	ME 1200B
Ordering codes	<b>1380540</b>	<b>1380541</b>	<b>1380542</b>	<b>1380543</b>	<b>1380544</b>	<b>1380545</b>	<b>1380546</b>	<b>1380547</b>
Controlled height (mm)	145	295	445	595	745	895	1045	1195
Num. of beams	30	60	90	120	150	180	210	240
Overall height (mm)	261	411	561	711	861	1011	1161	1311

Beam spacing 10 mm	ME 151A	ME 301A	ME 451A	ME 601A	ME 751A	ME 901A	ME 1051A	ME 1201A	ME 1351A	ME 1501A	ME 1651A	ME 1801A	ME 1951A	ME 2101A	ME 2251A	ME 2401A
Ordering codes	<b>1380000</b>	<b>1380001</b>	<b>1380002</b>	<b>1380003</b>	<b>1380004</b>	<b>1380005</b>	<b>1380006</b>	<b>1380007</b>	<b>1380008</b>	<b>1380009</b>	<b>1380010</b>	<b>1380011</b>	<b>1380012</b>	<b>1380013</b>	<b>1380014</b>	<b>1380015</b>
Beam spacing 10 mm	ME 151B	ME 301B	ME 451B	ME 601B	ME 751B	ME 901B	ME 1051B	ME 1201B	ME 1351B	ME 1501B	ME 1651B	ME 1801B	ME 1951B	ME 2101B	ME 2251B	ME 2401B
Ordering codes	<b>1380020</b>	<b>1380021</b>	<b>1380022</b>	<b>1380023</b>	<b>1380024</b>	<b>1380025</b>	<b>1380026</b>	<b>1380027</b>	<b>1380028</b>	<b>1380029</b>	<b>1380030</b>	<b>1380031</b>	<b>1380032</b>	<b>1380033</b>	<b>1380034</b>	<b>1380035</b>
Beam spacing 10 mm	ME 151C	ME 301C	ME 451C	ME 601C	ME 751C	ME 901C	ME 1051C	ME 1201C	ME 1351C	ME 1501C	ME 1651C	ME 1801C	ME 1951C	ME 2101C	ME 2251C	ME 2401C
Ordering codes	<b>1380040</b>	<b>1380041</b>	<b>1380042</b>	<b>1380043</b>	<b>1380044</b>	<b>1380045</b>	<b>1380046</b>	<b>1380047</b>	<b>1380048</b>	<b>1380049</b>	<b>1380050</b>	<b>1380051</b>	<b>1380052</b>	<b>1380053</b>	<b>1380054</b>	<b>1380055</b>
Controlled height (mm)	140	290	440	590	740	890	1040	1190	1340	1490	1640	1790	1940	2090	2240	2390
Num. of beams	15	30	45	60	75	90	105	120	135	150	165	180	195	210	225	240
Overall height (mm)	261	411	561	711	861	1011	1161	1311	1461	1611	1761	1911	2061	2211	2361	2511

Beam spacing 25 mm	ME 302A	ME 452A	ME 602A	ME 752A	ME 902A	ME 1052A	ME 1202A	ME 1352A	ME 1502A	ME 1652A	ME 1802A	ME 1952A	ME 2102A	ME 2252A	ME 2402A	ME 2552A
Ordering codes	<b>1380101</b>	<b>1380102</b>	<b>1380103</b>	<b>1380104</b>	<b>1380105</b>	<b>1380106</b>	<b>1380107</b>	<b>1380108</b>	<b>1380109</b>	<b>1380110</b>	<b>1380111</b>	<b>1380112</b>	<b>1380113</b>	<b>1380114</b>	<b>1380115</b>	<b>1380116</b>
Beam spacing 25 mm	ME 302B	ME 452B	ME 602B	ME 752B	ME 902B	ME 1052B	ME 1202B	ME 1352B	ME 1502B	ME 1652B	ME 1802B	ME 1952B	ME 2102B	ME 2252B	ME 2402B	ME 2552B
Ordering codes	<b>1380121</b>	<b>1380122</b>	<b>1380123</b>	<b>1380124</b>	<b>1380125</b>	<b>1380126</b>	<b>1380127</b>	<b>1380128</b>	<b>1380129</b>	<b>1380130</b>	<b>1380131</b>	<b>1380132</b>	<b>1380133</b>	<b>1380134</b>	<b>1380135</b>	<b>1380136</b>
Beam spacing 25 mm	ME 302C	ME 452C	ME 602C	ME 752C	ME 902C	ME 1052C	ME 1202C	ME 1352C	ME 1502C	ME 1652C	ME 1802C	ME 1952C	ME 2102C	ME 2252C	ME 2402C	ME 2552C
Ordering codes	<b>1380141</b>	<b>1380142</b>	<b>1380143</b>	<b>1380144</b>	<b>1380145</b>	<b>1380146</b>	<b>1380147</b>	<b>1380148</b>	<b>1380149</b>	<b>1380150</b>	<b>1380151</b>	<b>1380152</b>	<b>1380153</b>	<b>1380154</b>	<b>1380155</b>	<b>1380156</b>
Controlled height (mm)	275	425	575	725	875	1025	1175	1325	1475	1625	1775	1925	2075	2225	2375	2525
Num. of beams	12	18	24	30	36	42	48	54	60	66	72	78	84	90	96	102
Overall height (mm)	411	561	711	861	1011	1161	1311	1461	1611	1761	1911	2061	2211	2361	2511	2661

<b>Beam spacing 30 mm</b>	ME 303A	ME 453A	ME 603A	ME 753A	ME 903A	ME 1053A	ME 1203A	ME 1353A	ME 1503A	ME 1653A	ME 1803A	ME 1953A	ME 2103A	ME 2253A	ME 2403A	ME 2553A
Ordering codes	<b>1380201</b>	<b>1380202</b>	<b>1380203</b>	<b>1380204</b>	<b>1380205</b>	<b>1380206</b>	<b>1380207</b>	<b>1380208</b>	<b>1380209</b>	<b>1380210</b>	<b>1380211</b>	<b>1380212</b>	<b>1380213</b>	<b>1380214</b>	<b>1380215</b>	<b>1380216</b>
<b>Beam spacing 30 mm</b>	ME 303B	ME 453B	ME 603B	ME 753B	ME 903B	ME 1053B	ME 1203B	ME 1353B	ME 1503B	ME 1653B	ME 1803B	ME 1953B	ME 2103B	ME 2253B	ME 2403B	ME 2553B
Ordering codes	<b>1380221</b>	<b>1380222</b>	<b>1380223</b>	<b>1380224</b>	<b>1380225</b>	<b>1380226</b>	<b>1380227</b>	<b>1380228</b>	<b>1380229</b>	<b>1380230</b>	<b>1380231</b>	<b>1380232</b>	<b>1380233</b>	<b>1380234</b>	<b>1380235</b>	<b>1380236</b>
<b>Beam spacing 30 mm</b>	ME 303C	ME 453C	ME 603C	ME 753C	ME 903C	ME 1053C	ME 1203C	ME 1353C	ME 1503C	ME 1653C	ME 1803C	ME 1953C	ME 2103C	ME 2253C	ME 2403C	ME 2553C
Ordering codes	<b>1380241</b>	<b>1380242</b>	<b>1380243</b>	<b>1380244</b>	<b>1380245</b>	<b>1380246</b>	<b>1380247</b>	<b>1380248</b>	<b>1380249</b>	<b>1380250</b>	<b>1380251</b>	<b>1380252</b>	<b>1380253</b>	<b>1380254</b>	<b>1380255</b>	<b>1380256</b>
Controlled height (mm)	270	420	570	720	870	1020	1170	1320	1470	1620	1770	1920	2070	2220	2370	2520
Num. of beams	10	15	20	25	30	35	40	45	50	55	60	65	70	75	80	85
Overall height (mm)	411	561	711	861	1011	1161	1311	1461	1611	1761	1911	2061	2211	2361	2511	2661
<b>Beam spacing 50 mm</b>	ME 455A	ME 605A	ME 755A	ME 905A	ME 1055A	ME 1205A	ME 1355A	ME 1505A	ME 1655A	ME 1805A	ME 1955A	ME 2105A	ME 2255A	ME 2405A	ME 2555A	
Ordering codes	<b>1380302</b>	<b>1380303</b>	<b>1380304</b>	<b>1380305</b>	<b>1380306</b>	<b>1380307</b>	<b>1380308</b>	<b>1380309</b>	<b>1380310</b>	<b>1380311</b>	<b>1380312</b>	<b>1380313</b>	<b>1380314</b>	<b>1380315</b>	<b>1380316</b>	
<b>Beam spacing 50 mm</b>	ME 455B	ME 605B	ME 755B	ME 905B	ME 1055B	ME 1205B	ME 1355B	ME 1505B	ME 1655B	ME 1805B	ME 1955B	ME 2105B	ME 2255B	ME 2405B	ME 2555B	
Ordering codes	<b>1380322</b>	<b>1380323</b>	<b>1380324</b>	<b>1380325</b>	<b>1380326</b>	<b>1380327</b>	<b>1380328</b>	<b>1380329</b>	<b>1380330</b>	<b>1380331</b>	<b>1380332</b>	<b>1380333</b>	<b>1380334</b>	<b>1380335</b>	<b>1380336</b>	
<b>Beam spacing 50 mm</b>	ME 455C	ME 605C	ME 755C	ME 905C	ME 1055C	ME 1205C	ME 1355C	ME 1505C	ME 1655C	ME 1805C	ME 1955C	ME 2105C	ME 2255C	ME 2405C	ME 2555C	
Ordering codes	<b>1380342</b>	<b>1380343</b>	<b>1380344</b>	<b>1380345</b>	<b>1380346</b>	<b>1380347</b>	<b>1380348</b>	<b>1380349</b>	<b>1380350</b>	<b>1380351</b>	<b>1380352</b>	<b>1380353</b>	<b>1380354</b>	<b>1380355</b>	<b>1380356</b>	
Controlled height (mm)	400	550	700	850	1000	1150	1300	1450	1600	1750	1900	2050	2200	2350	2500	
Num. of beams	9	12	15	18	21	24	27	30	33	36	39	42	45	48	51	
Overall height (mm)	561	711	861	1011	1161	1311	1461	1611	1761	1911	2061	2211	2361	2511	2661	
<b>Beam spacing 75 mm</b>	ME 607A	ME 757A	ME 907A	ME 1057A	ME 1207A	ME 1357A	ME 1507A	ME 1657A	ME 1807A	ME 1957A	ME 2107A	ME 2257A	ME 2407A	ME 2557A		
Ordering codes	<b>1380403</b>	<b>1380404</b>	<b>1380405</b>	<b>1380406</b>	<b>1380407</b>	<b>1380408</b>	<b>1380409</b>	<b>1380410</b>	<b>1380411</b>	<b>1380412</b>	<b>1380413</b>	<b>1380414</b>	<b>1380415</b>	<b>1380416</b>		
<b>Beam spacing 75 mm</b>	ME 607B	ME 757B	ME 907B	ME 1057B	ME 1207B	ME 1357B	ME 1507B	ME 1657B	ME 1807B	ME 1957B	ME 2107B	ME 2257B	ME 2407B	ME 2557B		
Ordering codes	<b>1380423</b>	<b>1380424</b>	<b>1380425</b>	<b>1380426</b>	<b>1380427</b>	<b>1380428</b>	<b>1380429</b>	<b>1380430</b>	<b>1380431</b>	<b>1380432</b>	<b>1380433</b>	<b>1380434</b>	<b>1380435</b>	<b>1380436</b>		
<b>Beam spacing 75 mm</b>	ME 607C	ME 757C	ME 907C	ME 1057C	ME 1207C	ME 1357C	ME 1507C	ME 1657C	ME 1807C	ME 1957C	ME 2107C	ME 2257C	ME 2407C	ME 2557C		
Ordering codes	<b>1380443</b>	<b>1380444</b>	<b>1380445</b>	<b>1380446</b>	<b>1380447</b>	<b>1380448</b>	<b>1380449</b>	<b>1380450</b>	<b>1380451</b>	<b>1380452</b>	<b>1380453</b>	<b>1380454</b>	<b>1380455</b>	<b>1380456</b>		
Controlled height (mm)	525	675	825	975	1125	1275	1425	1575	1725	1875	2025	2175	2325	2475		
Num. of beams	8	10	12	14	16	18	20	22	24	26	28	30	32	34		
Overall height (mm)	711	861	1011	1161	1311	1461	1611	1761	1911	2061	2211	2361	2511	2661		

► "ACCESSORIES" on page 217



**WARNING!**

When the light curtain works in the presence of strong vibrations (presses, weaving machines etc.), in order to avoid damages to the light curtain it is necessary to use the vibration dampers SAV (available as accessories)

When long range protections or perimeter protections employing mirrors have to be realised it is advisable to use the LAD 2 laser pointer as an alignment aid, as well as the adjustable swivel fastening brackets SFB.



## DIMENSION (mm)

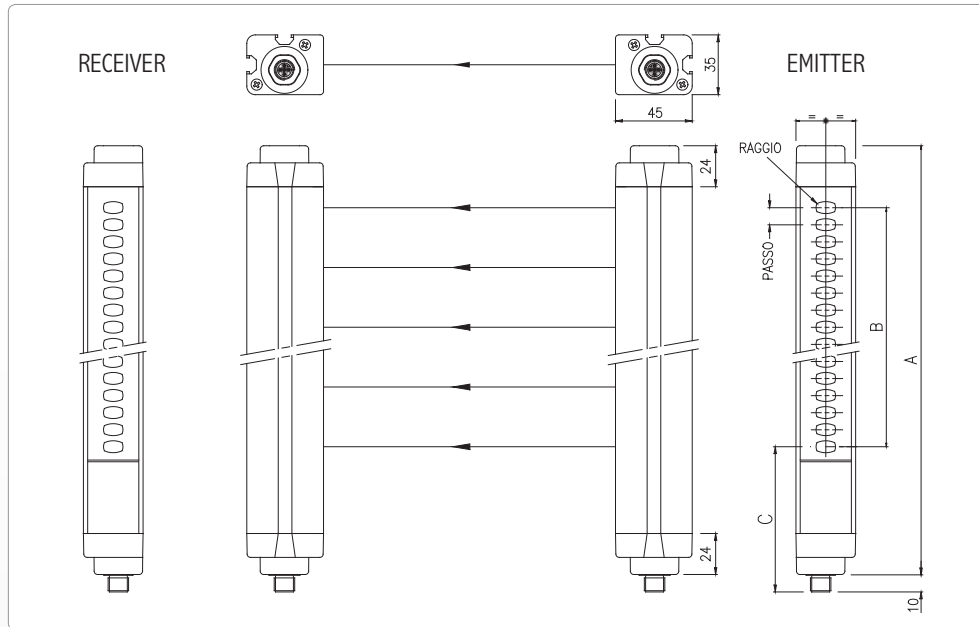

Model ME	150	300	450	600	750	900	1050	1200
<b>A</b>	251	401	551	701	851	1001	1151	1301
<b>B (controlled height)</b>	$B = (\text{number of beams} - 1) \times \text{beam spacing (with cable synchronisation)}$ $B = (\text{number of beams} - 2) \times \text{beam spacing (with optical synchronisation)}^*$							
<b>C (1<sup>st</sup> beam position)</b>	85 (for 10, 30 models) - 93 (for 25, 50, 75 models)							
<b>Mounting</b>	Complete set of 4 LS type brackets included in the package							

Model ME	1350	1500	1650	1800	1950	2100	2250	2400	2550
<b>A</b>	1451	1601	1751	1901	2051	2201	2351	2501	2651
<b>B (controlled height)</b>	$B = (\text{number of beams} - 1) \times \text{beam spacing (with cable synchronisation)}$ $B = (\text{number of beams} - 2) \times \text{beam spacing (with optical synchronisation)}^*$								
<b>C (1<sup>st</sup> beam position)</b>	85 (for 10 - 30 models) - 93 (for 25-50-75 models)								
<b>Mounting</b>	Complete set of 6 LS type brackets included in the package								

\* In the case of optical synchronism, the beam adjacent to the upper end cap cannot be used for measurement, as it constitutes the synchronism beam.

## ORDERING INFORMATION

In addition to the height and beam spacing, to uniquely define a Metron light curtain the model must also be indicated A, B or C:

<b>Models A</b>	4 outputs with programmable functions (e.g.: ME 1801 A)
<b>Models B</b>	RS-485 serial line + 2 solid state outputs 0 or 24V with programmable functions (e.g.: ME 1801 B)
<b>Models C</b>	2 solid state outputs 0 or 24V antivalent (without the need for programming) (e.g.: ME 1801 C)

Each type of Metron light curtain includes:

- Emitter and Receiver pair
- Mounting brackets and T-nuts
- CD-ROM containing the "Metronconf" programming software and the multi-language instruction manual

**ACCESSORIES**

**For Metron light curtains the following accessories, to be ordered separately, are available:**

FMC floor mounting columns	▶ See page 220
SP deflection mirrors	▶ See page 223
LAD laser alignment device	▶ See page 224
SAV vibrations dampers	▶ See page 225
SFB swivel fixing brackets	▶ See page 226
Connectors	▶ See list hereunder:

**CONNECTORS METRON A and B emitters**

Model	Code	Description
C8D 5	1330980	M12 straight connector, 8 poles, pre-wired cable 5 m
C8D 10	1330981	M12 straight connector, 8 poles, pre-wired cable 10 m
C8D 15	1330982	M12 straight connector, 8 poles, pre-wired cable 15 m
C8D 25	1330967	M12 straight connector, 8 poles, pre-wired cable 25 m
C8D 40	1440966	M12 straight connector, 8 poles, pre-wired cable 40 m
C8D 95	1330983	M12 90° angle connector, 8 poles, pre-wired cable 5 m
C8D 910	1330984	M12 90° angle connector, 8 poles, pre-wired cable 10 m
C8D 915	1330985	M12 90° angle connector, 8 poles, pre-wired cable 15 m
C8DM 9	1330986	M12 straight connector, 8 poles with screw terminal, PG9 cable gland
C8DM 99	1330987	M12 angle connector, 8 poles with screw terminal, PG9 cable gland
C8DM 11	1330978	M12 straight connector, 8 poles with screw terminal, PG9/11 cable gland
C8DM 911	1330979	M12 angle connector, 8 poles with screw terminal, PG9/11 cable gland

**CONNECTORS METRON A and B receivers**

Model	Code	Description
C12D 3	1330991	M16 straight connector, 12 poles, pre-wired cable 3 m
C12D 5	1330992	M16 straight connector, 12 poles, pre-wired cable 5 m
C12D 10	1330993	M16 straight connector, 12 poles, pre-wired cable 10 m
C12D 15	1330996	M16 straight connector, 12 poles, pre-wired cable 15 m
C12D 25	1330948	M16 straight connector, 12 poles, pre-wired cable 25 m
CSL 3	1330994	3 meters cable, for connecting light curtain and PC for system configuration, equipped with one M8 3-pole connector and one DB9 connector

**CONNECTORS METRON C emitters and receivers**

Model	Code	Description
CD 5	1330950	M12 straight connector, 5 poles, pre-wired cable 5 m
CD 10	1330956	M12 straight connector, 5 poles, pre-wired cable 10 m
CD 15	1330952	M12 straight connector, 5 poles, pre-wired cable 15 m
CD 20	1330957	M12 straight connector, 5 poles, pre-wired cable 20 m
CD 25	1330949	M12 straight connector, 5 poles, pre-wired cable 25 m
CD 50	1330965	M12 straight connector, 5 poles, pre-wired cable 50 m
CD 95	1330951	M12 90° angle connector, 5 poles, pre-wired cable 5 m
CD 910	1330958	M12 90° angle connector, 5 poles, pre-wired cable 10 m
CD 915	1330953	M12 90° angle connector, 5 poles, pre-wired cable 15 m
CDM 9	1330954	M12 straight connector, 5 poles with screw terminal, PG9 cable gland
CDM 99	1330955	M12 angle connector, 5 poles with screw terminal, PG9 cable gland



# ACCESSORIES

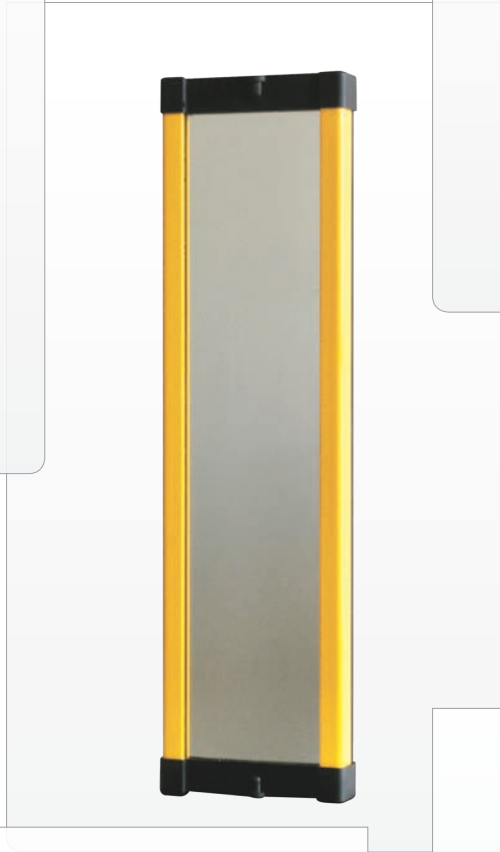
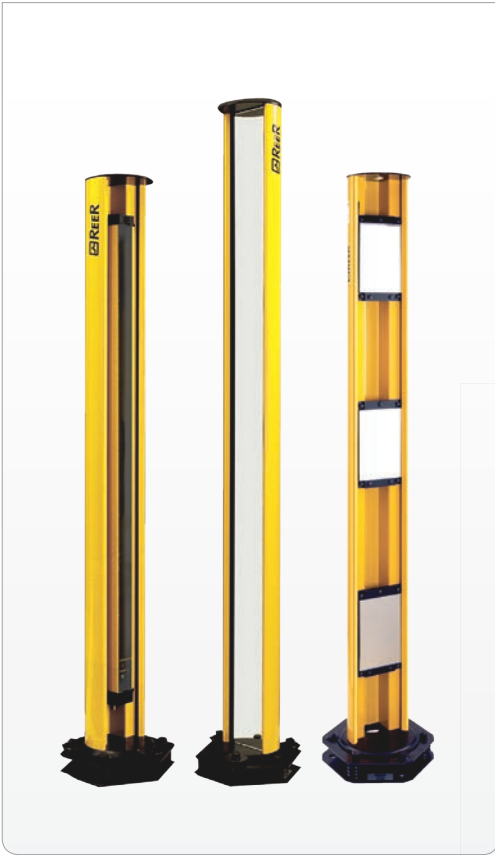

## FMC - FLOOR SUPPORT COLUMNS

**Support columns for Reer safety light curtains and deflection mirrors, designed to provide secure fastening to the floor, fast installation, and a simple and precise adjustment of the optical alignment of the system.**

### MAIN FEATURES

- Steel base with springs for a perfect adjustment of the column vertical axis.
- Columns made by aluminium extrusion poles, with adjustable angular orientation.
- Easy assembling and disassembling of the light curtain with easy adjustment of the first beam's height.
- FMC E and FMC B models for light curtains.
- FMC E\_R and FMC B\_R models for light curtains complete with PG11 rear union for light curtain cable sheath.
- FMC S models with pre-assembled deflector mirrors to realize perimeter protections up to 4 sides.
- FMC-SB models with pre-installed independent adjustable deflection mirrors for safety light grids with 2, 3 and 4 beams. [NEW PRODUCT]
- Optical power reduction factor 15% (for each mirror).
- Special models equipped with mirror with protective anti-fragmentation film available on request.
- Steel foundation inserts included with the product.
- Built-in spirit level for a correct positioning of the vertical axis.

Can be used with the following light curtains:

light curtains	Columns for light curtains	Columns with mirrors
EOS	models FMC EB / FMC EBR	FMC S with single mirror FMC SB with 2, 3, 4 mirrors
MICRON		
ADMIRAL	models FMC B / models FMC BR	
JANUS		
VISION		
METRON		



**PG11  
Cable gland**

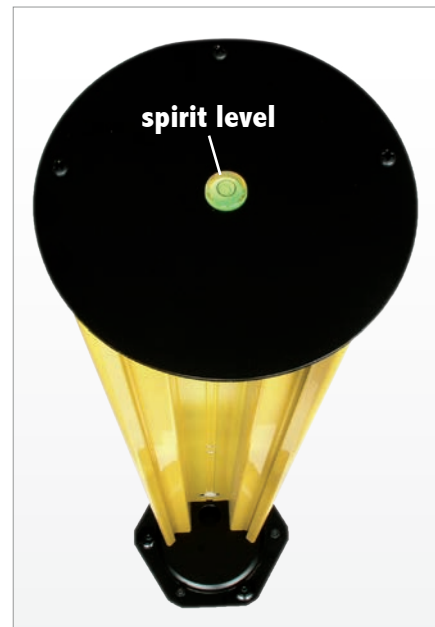

**spirit level**

## FMC - FLOOR SUPPORT COLUMNS

### TECHNICAL FEATURES AND DIMENSIONS (mm)

<b>COLUMNS FOR LIGHT CURTAINS - JANUS - VISION - ADMIRAL - METRON</b>					
Standard Models	FMC-B2	FMC-B3	FMC-B4	FMC-B1700	FMC-B2000
Ordering code	1200610	1200611	1200612	1200618	1200616
Models with PG11 rear union for cable sheath	FMC-B2R	FMC-B3R	FMC-B4R	FMC-B1700R	FMC-B2000R
Ordering code	1200613	1200614	1200615	1200617	1200619
For light curtains with:	2 beams	3 beams	4 beams	controlled height up to 1360 mm	controlled height up to 1660 mm
Overall height with base (mm)	1055	1255	1385	1725	2025

<b>COLUMNS FOR LIGHT CURTAINS - EOS - MICRON</b>				
Standard Models	FMC-EB2	FMC-EB4	FMC-EB1700	FMC-EB2000
Ordering code	1200613	1207815	1207815	1207817
Models with PG11 rear union for cable sheath	FMC-EB2R	FMC-EB4R	FMC-EB1700R	FMC-EB2000R
Ordering code	1207824	1207825	1207826	1207827
For light curtains with:	controlled height 310, 460, 610, 2 beams	controlled height 760, 910, 1060, 3 and 4 beams	controlled height up to 1360 mm	controlled height up to 1660 mm
Overall height with base (mm)	1055	1255	1725	2025

<b>COLUMNS WITH DEFLECTION MIRROR</b>								
Models	FMC-S2	FMC-SB2	FMC-S3	FMC-SB3	FMC-S4	FMC-SB4	FMC-S1700	FMC-S2000
Ordering code	1200620	1200645	1200621	1200646	1200622	1200647	1200625	1200623
Description	single mirror for 2 beams light curtains	2 mirrors for 2 beams light curtains	single mirror for 3 beams light curtains	3 mirrors for 3 beams light curtains	single mirror for 4 beams light curtains	4 mirrors for 4 beams light curtains	controlled height up to 1360 mm	controlled height up to 1660 mm
Overall height with base (mm)	1055		1255		1385		1725	2025

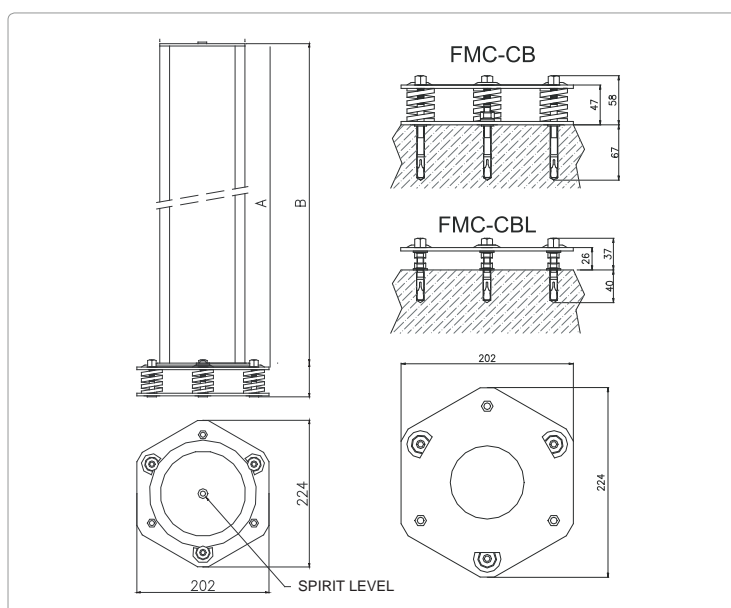

Model	A	B
<b>COLUMNS FOR LIGHT CURTAINS</b>		
FMC-B2/EB2	1000	1055
FMC-B3	1200	1255
FMC-B4/EB4	1330	1385
FMC-B1700/EB1700	1670	1725
FMC-B2000/EB2000	1970	2025
<b>COLUMNS WITH DEFLECTION MIRROR</b>		
FMC-S2/SB2	1000	1055
FMC-S3/SB3	1200	1255
FMC-S4/SB4	1330	1385
FMC-S1700	1670	1725
FMC-S2000	1970	2025
<b>BASE FOR COLUMNS</b>		
FMC-CB	202 x 224 x 55 h	
FMC-CBL	202 x 224 x 37 h	
Each floor mounting columns includes multi-language instruction manual		

# FMC-B12 - FMC-B18 - SUPPORT COLUMNS

## MAIN FEATURES

Simplified version for 2, 3, 4 beams light grids. It permits the use with light grids with integrated Muting sensors:  
 Janus MT and ML, Vision MXL L and MXL T.  
 FMC-B12 can also be used with: Admiral, Vision, EOS4 and EOS2, Micron and Metron.

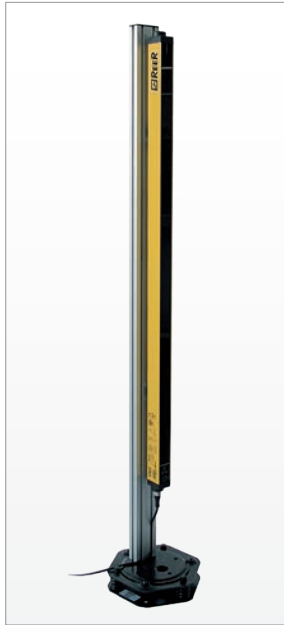

## COLUMNS FOR LIGHT CURTAINS

Model	FMC-B12	FMC-B18
Ordering code	1200502	1200505

Each column includes: fixing brackets and multi-language instruction manual.

## DIMENSIONI (mm)

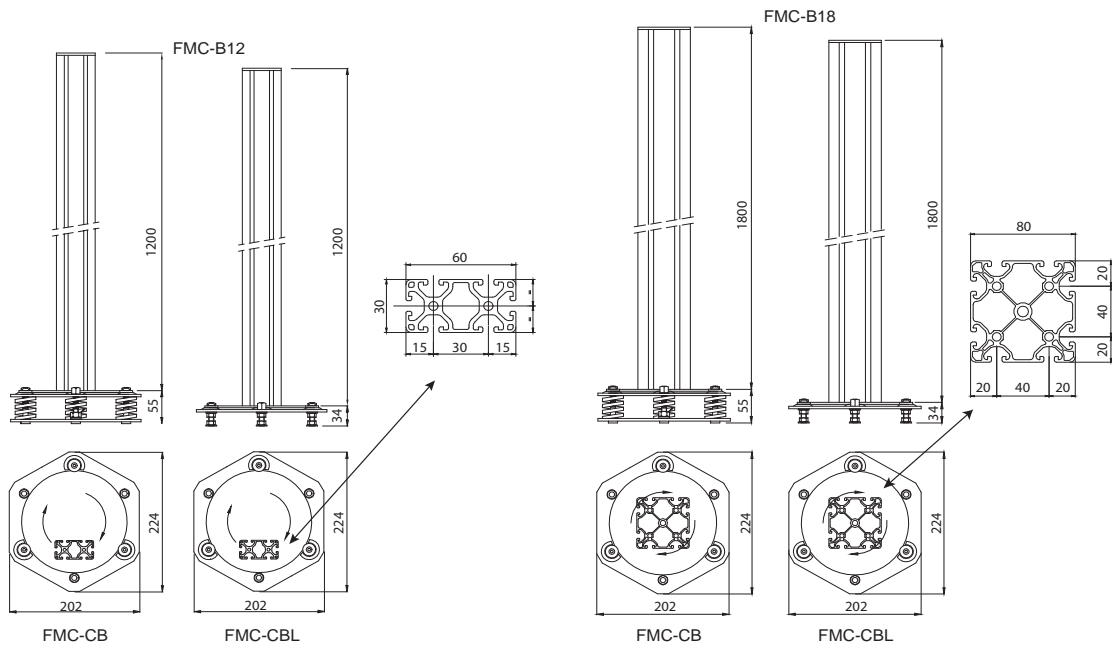

# SP - DEFLECTION MIRRORS

The SP deflection mirrors make it possible to create perimeter protection of areas with access points on multiple sides, with a considerable reduction of costs.

This solution eliminates the need to use more than one safety light curtain.

## MAIN FEATURES

- Extruded aluminium section bar.
- Mirror pre-fitted with heights from 250 to 1900 mm.
- Angular orientation adjustable using supplied brackets.
- Optical power reduction factor 15% (for each mirror).
- Special models equipped with mirror with protective anti-fragmentation film available on request.
- Can be used to realise perimeter protection up to 4 sides.



## Dimensions (mm) & mirror-light curtain combinations

Mirror Model	Ordering code	Dimension H in picture	For light curtains with protected height (mm)	For light grids with:
<b>SP 100 S</b>	1201805	250	160	
<b>SP 300 S</b>	1201806	400	310	
<b>SP 400 S</b>	1201801	540	460	
<b>SP 600 S</b>	1201811	715	610	2 beams
<b>SP 700 S</b>	1201802	885	760	
<b>SP 900 S</b>	1201812	1065	910	3 beams
<b>SP 1100 S</b>	1201803	1230	1060	4 beams
<b>SP 1200 S</b>	1201810	1400	1210	
<b>SP 1300 S</b>	1201807	1450	1360	
<b>SP 1500 S</b>	1201808	1600	1510	
<b>SP 1600 S</b>	1201813	1750	1660	
<b>SP 1800 S</b>	1201809	1900	1810	

Each mirror is supplied with two adjustable fixing brackets  
 Each SP Mirror includes: multi-language instruction manual.

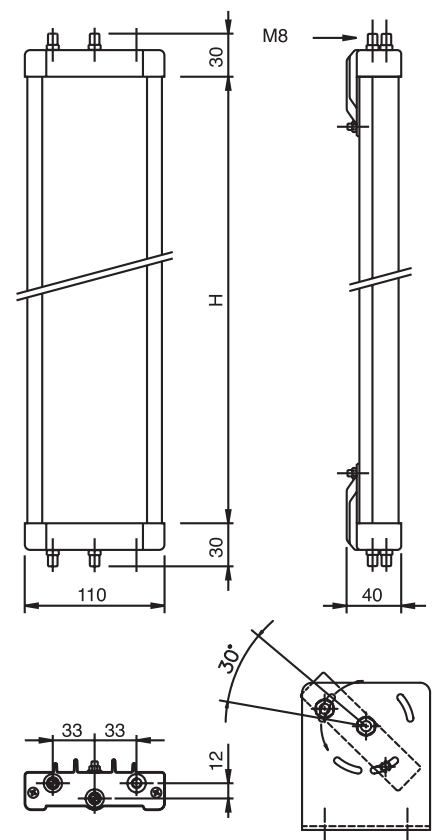

## WARNING!

- The following rules should be taken into consideration when using deflector mirrors:
- the working distance (range) is given by the sum of the lengths of all the sides giving access to the protected area.
  - for each mirror used the maximum working range between the Emitter and the Receiver is reduced by 15%.
  - place the mirrors in order to ensure compliance with the minimum safety distance on each side from which the danger zone can be accessed.
  - when light curtains and grids are working with long distance or with deflector mirrors, it is recommendable to use the LAD laser pointer for a quick and reliable alignment of the system.



# LAD - LASER ALIGNMENT DEVICE

## MAIN FEATURES

The LAD laser alignment device makes it possible to obtain a fast and reliable optical alignment of the Reer safety light curtains of the EOS4 and EOS2, Admiral, Vision, Micron, Metron and Janus series; they are also compatible with the use of the FMC floor mounting columns.

The LAD devices emit a laser beam with visible red light with useful range up to 100 m.

Their use is recommended for aligning light curtains that operate over long distances or multiple sides with the use of deflection mirrors.



## TECHNICAL FEATURES

<b>Light source</b>	laser diode – wavelength 650 nm
<b>Class light source</b>	II – EN 60825-1
<b>Range m</b>	100
<b>Beam divergence (mrd)</b>	< 0,5
<b>Max. power (mW)</b>	1
<b>Power supply (VDC)</b>	3 (2 AAA batteries)
<b>Fastening</b>	quick fastening to the light curtains
<b>Dimensions (h x w x d) mm</b>	117 x 48 x 80 - LAD 2 - LAD 4 70 x 78 x 70 - LAD 3



Model	Ordering code	for light curtains:
<b>LAD 2</b>	1220301	Admiral - Vision - Metron
<b>LAD 3</b>	1220302	Janus
<b>LAD 4</b>	1310975	EOS4 - EOS2 - Micron

## DIMENSIONS (mm)

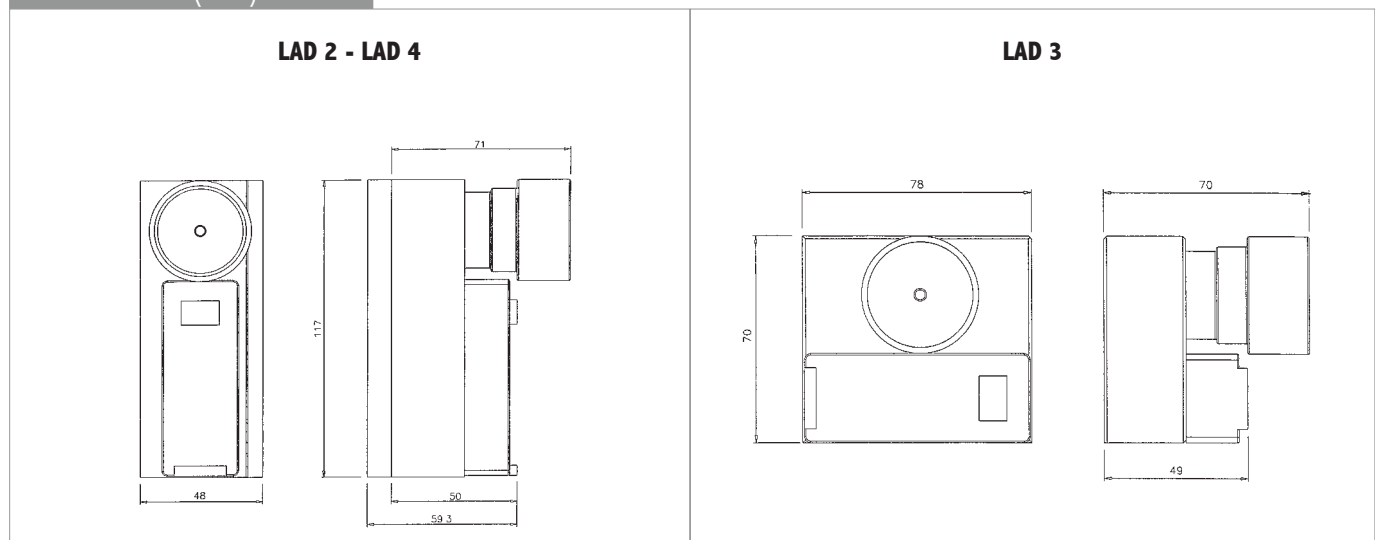

Each LAD model includes multi-language instruction manual.

## SAV - VIBRATION DAMPERS

### MAIN FEATURES

The SAV vibration dampers have been designed to avoid mechanical damage to the light curtains installed in those applications which have a high level of vibrations.

The unprotected light curtains might resent the vibrations produced by e.g. presses, weaving machines, etc.

In these cases, the use of SAV vibration dampers is highly recommended.

- SAV 4E-8E-12E dampers are to be used with EOS4/EOS2 and Micron light curtains
- SAV 1 and SAV 2 dampers are to be used with Janus light curtains
- SAV 3 and SAV 4 dampers are to be used with Admiral, Vision and Metron.



### TECHNICAL FEATURES

Model	Ordering code	Description	for light curtains with protected height mm / beams	Light curtains model
SAV 1	1200084	set 4 vibrations dampers	310 ... 1060 / 2, 3, 4	Janus
SAV 2	1200085	set 6 vibrations dampers	1210 ... 1810	
SAV 3	1200088	set 2 vibrations dampers	160 ... 1060 / 2, 3, 4	Admiral - Vision - Metron
SAV 4	1200089	set 3 vibrations dampers	1210 ... 1810	
SAV 4E	1310972	set 4 vibrations dampers	160	EOS4 - EOS2 - Micron
SAV 8E	1310973	set 8 vibrations dampers	310 ... 1050	
SAV 12E	1310974	set 12 vibrations dampers	1210 ... 1810	

For EOS4, EOS2 and Micron 1 set must be ordered for each light curtain. For Janus, Admiral, Vision and Metron 2 sets must be ordered for each light curtain (1 set for the emitter + 1 for the receiver).

## PROTECTIVE SCREEN FOR EOS

### MAIN FEATURES

PSE is a polycarbonate protective screen that preserves the light curtain's front screen from damages due to welding sparks or due to the presence of acids in the workspace.

Once no more usable the protective screen can be quickly replaced thanks to its fast and easy stainless steel clamping system.

The protective screens are available for any protected heights of the EOS and Micron range.

Each kit includes:

- **SFS E** (ordering code **1310981**) - 1 set of stainless steel clamps for one safety light curtain (emitter and receiver)
- **PSEx** (ordering code from **1310982** to **1310995** according to the length of light curtain) - 4 protective screens (2 as spare parts).

For each pairs of safety light curtain (emitter and receiver) it's necessary orderd both codes.



Model	PSE 150	PSE 300	PSE 450	PSE 600	PSE 750	PSE 900	PSE 1050	PSE 1200	PSE 1350	PSE 1500	PSE 1650	PSE 1800
Ordering code	1310982	1310983	1310984	1310985	1310986	1310987	1310988	1310989	1310990	1310991	1310992	1310996

Model	PSE 2B	PSE 3B	PSE 4B
Ordering code	1310993	1310994	1310995

Model	SFS E
Ordering code	1310981

## SFB – SFB 4J - SFBE – SFB E180 - BRACKETS

### MAIN FEATURES

The SFB/SFBE/SFB180E swivel brackets allow the rotation of the light curtain around its longitudinal axis, as well as the adjustment of its vertical and horizontal position.

The use of the SFB/SFBE/SFB180E swivel brackets is recommended to align those light curtains which are employed in applications having a long range or using deflector mirrors.

SFB: are to be used with Admiral, Vision and Metron.

SFB 4J: are to be used with Janus.

SFB 4E - SFB 6E - SFB E180: are to be used with EOS4, EOS2 and Micron.



SFB 4E  
SFB 6E

### TECHNICAL FEATURES

Model	Ordering code	Description
<b>SFB</b>	<b>1330974</b>	set of 4 swivel brackets for: Admiral, Vision e Metron
<b>SFB 4J</b>	<b>1360068</b>	set of 4 swivel brackets for: Janus
<b>SFB 4E</b>	<b>1310976</b>	set of 4 swivel brackets for: EOS and Micron with length $\leq$ 1200 mm
<b>SFB 6E</b>	<b>1310977</b>	set of 6 swivel brackets for: EOS and Micron with length $\geq$ 1200 mm
<b>SFB E180</b>	<b>1310980</b>	set or 4 180° swivel brackets for EOS and Micron

One set must be ordered for each pair of light curtain (emitter + receiver)



SFB

SFB E180

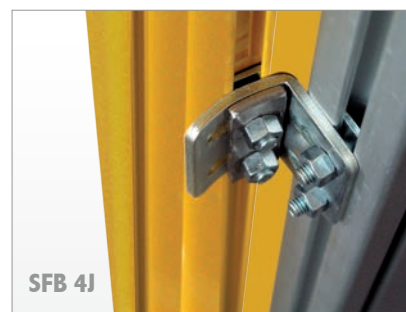

SFB 4J

## TEST ROD

### MAIN FEATURES

The test rod is an opaque cylinder used after the installation of a safety light curtain to check that no beams are bypassed due to the presence of reflecting surfaces.

The test is carried out by slowly moving the test rod ( $\emptyset$  = Resolution) in the centre and then along each side of the protected area. During this procedure the Green led on the Receiver must always remain in the off state.

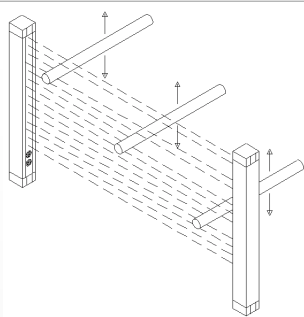

### TECHNICAL FEATURES

Model	Ordering code	Diameter
<b>TR 14</b>	<b>1330960</b>	$\emptyset$ 14 mm
<b>TR 20</b>	<b>1330961</b>	$\emptyset$ 20 mm
<b>TR 30</b>	<b>1330962</b>	$\emptyset$ 30 mm
<b>TR 40</b>	<b>1330963</b>	$\emptyset$ 40 mm
<b>TR 50</b>	<b>1330964</b>	$\emptyset$ 50 mm

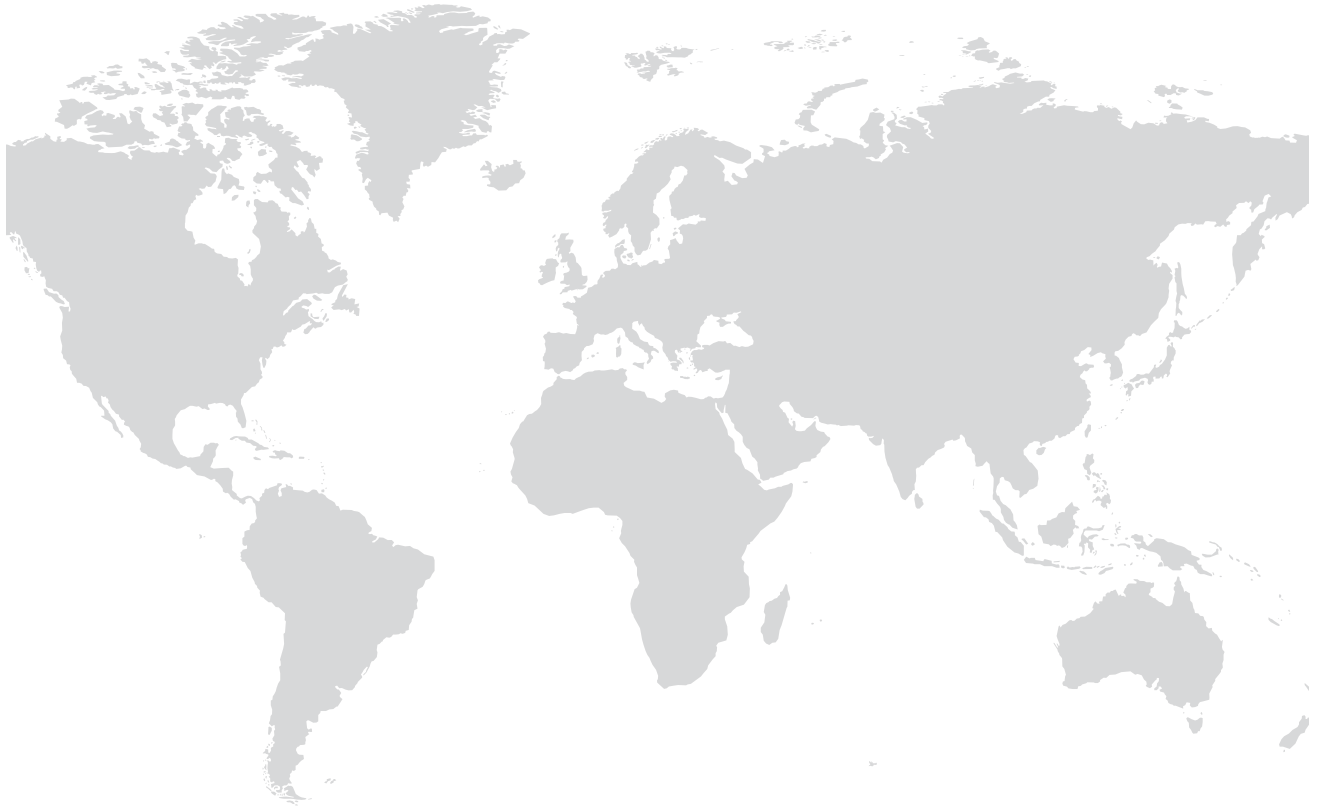
**REER SALES AND MAINTENENCE NETWORK IN ITALY AND WORLDWIDE**

**To see Reer's worldwide sales network click on Reer International on  
[www.reer.it](http://www.reer.it)**

**DISCLAIMER**

The products described in this catalog can be modified by Reer SpA without prior notice.

The catalogue does not therefore constitute any obligation for the manufacturer at the moment of purchase regarding the availability and the characteristics of the products described in it.

The law and Standard requirements can vary in their turn. All the information concerning applications is given as a pure indication and Reer does not assume any responsibility in that sense: concerning your application, refer only to its detailed risk analysis; concerning the use of Reer products, refer to their user manual and contact the manufacturer directly in any case of doubt.

